



# Village of Hastings-on-Hudson

July 18, 2023

## Geothermal and Heat Pump Feasibility Assessment



# contents

- Section A** Executive Summary
  - *Total Project Summary*
- Section B** Existing System
- Section C** Energy Usage
- Section D** Thermal Loading
- Section E** Proposed System
- Section F** Implementation Plan
  - *Likely Scope of Work*
  - *Opinion of Probably Costs*
  - *Incentives & Rebates*
  - *Financing and Ownership Models*
- Section G** Next Steps
  - *Design Considerations*
  - *Project Delivery Methods and Timeline*

# appendices

- Appendix 1** Utilities
- Appendix 2** Existing Equipment Inventory
- Appendix 3** Energy Savings Calculations
- Appendix 4** Schematics
- Appendix 5** Cut Sheets





# section a

---

executive summary

## EXECUTIVE SUMMARY

**BASELINE SUMMARY**  
*Village Hall and Library*

---

**Annual Energy Cost**  
\$84,152

**Annual Energy Usage**  
2,348 mmBtu  
65% Natural Gas  
35% Electric

**Annual Energy Emissions**  
94 MT CO<sub>2</sub>e

**Total Building Area**  
23,820 sqft

**Energy Usage Intensity (EUI)**  
99 kBtu/sqft

**RECOMENDED PROJECT**  
*Village Hall and Library*

---

**Annual Energy Savings**  
\$37,930

**Annual Energy Usage**  
722 mmBtu  
0% Natural Gas  
100% Electric

**Annual Energy Emissions**  
5 MT CO<sub>2</sub>e

**Total Building Area**  
23,820 sqft

**Total Payback (w/Max Incentive)**  
7 Years

### OBJECTIVE

The Village of Hastings-on-Hudson has identified an opportunity to implement a geothermal heat pump system and/or energy district inclusive of the Village of Hastings-on-Hudson’s Village Hall and Public Library. This study is a feasibility assessment to recommend a reasonable go/no go decision to further pursue this project through additional design and construction phases as determined by the Village of Hastings-on-Hudson.

The analysis provided in this investigation is focused on the following buildings.

Owner	Building	Area (sq ft)
Village of Hastings-on-Hudson	Village Hall	10,595
Village of Hastings-on-Hudson	Public Library	13,225
<b>Total Area:</b>		<b>23,820</b>

### INVESTIGATION APPROACH

As part of an initial investigation phase, Wendel assessed the opportunity to use geothermal and heat recovery heat pumps in two of the Village’s buildings, the Village Hall and Library. The preliminary study concluded that the project would yield good savings however was constrained by available space and systems within the existing buildings.

- Initial assessment of building utilities utilizing monthly utility data provided by the end-users.
- Interview of facility managers to understand existing systems major HVAC systems, age and limitations.
- Initial thermal modeling based on extrapolated monthly energy data.
- Review of drawings and facility interviews to identify:
  - Likely HVAC upgrades
  - Likely Electrical upgrades
  - Likely Equipment locations



- Likely Pipe routing
- Likely Well field locations
- Opinion of probable costs (high / low estimates)
- Opinion of probable energy savings (high / low estimates)
- Overview letter report outlining the system options, constraints, costs and benefits. This report will also outline a recommended implementation strategy including next steps and phasing options.

**STRATEGY OVERVIEW**

The strategy investigated in this report entails converting the Village Hall and Library to electric source heating that utilizes a geothermal wellfield in the parking lot. While the Library will likely need minimal modifications to convert to a geothermal/heat pump heating and cooling system, the Village Hall will require a number of “make-ready” building projects. Currently, the Village Hall utilizes steam radiators for space heating and DX Packaged Terminal Air Conditioners (PTACs) for space cooling. As part of the developed strategies, the steam distribution system and existing PTACs would be abandoned or removed, and replaced with either a neutral-temperature distribution loop or individual air source heat pumps. In addition, the building is predominantly unventilated, and a major HVAC renovation would also provide the opportunity for the addition of new ventilation air to improve Indoor Air Quality (IAQ). This project would be a comprehensive overhaul of the Village Hall’s HVAC system, which has reached or is reaching the end of its useful life, and, in addition to allowing for a full conversion to a modern BMS controls system for added energy savings, it would also improve IAQ and occupant comfort.



**Figure 1.** A summary of the existing heating and cooling distribution systems at the Village Hall and Library

There are two Strategies presented as part of this study. Strategy 1 utilizes a central Water-to-Water heat pump at the Library and console Water Source Heat Pumps (WSHPs) at the Village Hall, all connected via a neutral temperature distribution loop tied to a geothermal wellfield for heat rejection/absorption. Strategy 2 uses a similar heat pump system, but instead of rejecting/absorbing heat to a geothermal wellfield, it utilizes air-source technology and avoids a wellfield and the associated piping. These Strategies and the impacted building changes are summarized in the table below, as well as in the following sections.

	Equipment	Heating		Cooling	
		Village Hall	Library	Village Hall	Library
Strategy 1	Ground Source Water-to-Water Heat Pump and Terminal WSHPs	Remove Steam/Add Neutral Temp Piping w/WSHPs	Extend HW connections to new Water-to-Water HP. Existing terminal systems to remain	Remove PTACs/Add Neutral Temp Piping w/WSHPs	Replace chiller with Water-to-Water HP. Existing terminal systems to remain
Strategy 2	Air-to-Water Heat Pump and Terminal ASHPs	Remove Steam/Add ASHPs	Extend HW connections to new Air-to-Water HP. Existing terminal systems to remain	Remove PTACs/Add ASHPs	Replace chiller with Air-to-Water HP. Existing terminal systems to remain

**Table 1.** A summary of the proposed Heat Pump Strategies

In addition to these geothermal/heat pump heating measures, two solar PV measures were also developed to add renewable electricity generation capabilities to the site.

With steam and other fossil-fuel heating sources being phased out, these strategies provide the opportunity for a big push towards electrification and deep carbon-emissions reductions. Furthermore, a geothermal/heat pump system with a neutral temperature loop would modernize the buildings, and potentially provide the flexibility long-term to on expand the systems in the future to create or tie into a district thermal loop serving the Village’s center.



**STRATEGY 1 (GEOHERMAL HEAT PUMP SYSTEM)**

The following diagram shows the building level and distribution level changes that comprise the Geothermal Heat Pump solution proposed in Strategy 1. This solution will upgrade existing infrastructure, provide a new central water-to-water heat pump at the Library, terminal Water Source Heat Pumps and a new parking lot wellfield.



Figure 2. A summary of the proposed system changes included in Strategy 1

	Scenario 1 (30% ITC)	Scenario 2 (40% ITC)	
<b>TOTAL COST:</b>	\$1,739,213	\$1,739,213	A
<b>ENERGY COST SAVINGS:</b>	\$5,155	\$5,155	B
<b>OPERATIONAL &amp; MAINTENANCE SAVINGS:</b>	\$1,849	\$1,849	C
<b>EMISSIONS SAVINGS:</b>	48	48	D
<b>AVOIDED CAPITAL COST:</b>	\$994,156	\$994,156	E
<b>INCENTIVES &amp; IRA TAX CREDITS:</b>	\$521,764	\$695,685	F
<b>PAYBACK WITH INCENTIVES:</b>	32	7	G
<b>% ELECTRIFICATION OF HEATING:</b>	100%	100%	H
<b>% ENERGY SAVINGS:</b>	47%	47%	I
<b>% EMISSIONS SAVINGS:</b>	51%	51%	J
<b>% EMISSIONS SAVINGS (w/Library PV):</b>	94%	94%	K
<b>PAYBACK WITH INCENTIVES (w/Library PV):</b>	11	7	L
<b>% EMISSIONS SAVINGS (w/Full Renewables):</b>	100%	100%	M

Notes

- [G & L] Payback includes incentives and avoided capital costs.
- [F] Incentives are based on NY Sun program and the Section 48 Alternative Energy Investment Tax Credit (ITC) as amended by the Inflation Reduction Act. Two incentive scenarios are provided for analysis, one using 30% of the project cost of geothermal equipment and the other adding the 10% Domestic Content provision for a total of 40% of the cost.
- [J, K & M] % Emission savings with renewables demonstrates the overall emissions reduction if these projects are implemented and corresponding electrical energy is purchased via a renewable energy source.

**STRATEGY 2 (AIR SOURCE HEAT PUMP SYSTEM)**

Strategy 2 is proposed as a potential lower-cost alternative to a geothermal wellfield. Strategy 2 utilizes Air Source Heat Pumps for heat absorption/rejection as opposed to the geothermal wellfield outlined in Strategy 1. This includes a central air-to-water heat pump at the Library and terminal Air Source Heat Pumps (ASHPs) at the Village Hall. No piping connections would need to be added, and the buildings would not be thermally connected.



Figure 3. A summary of the proposed system changes included in Strategy 2

	<b>Probable</b>	
<b>TOTAL COST:</b>	\$912,038	A
<b>ENERGY COST SAVINGS:</b>	\$1,578	B
<b>OPERATIONAL &amp; MAINTENANCE SAVINGS:</b>	\$2,329	C
<b>EMISSIONS SAVINGS:</b>	44	D
<b>AVOIDED CAPITAL COST:</b>	\$930,490	E
<b>INCENTIVES &amp; IRA TAX CREDITS:</b>	\$0	F
<b>PAYBACK WITH INCENTIVES:</b>	N/A	G
<b>% ELECTRIFICATION OF HEATING:</b>	100%	H
<b>% ENERGY SAVINGS:</b>	45%	I
<b>% EMISSIONS SAVINGS:</b>	46%	J
<b>% EMISSIONS SAVINGS (w/Library PV):</b>	90%	K
<b>PAYBACK WITH INCENTIVES (w/Library PV):</b>	6	L
<b>% EMISSIONS SAVINGS (w/Full Renewables):</b>	100%	M

- Notes
- [G & L] Payback includes incentives and avoided capital costs.
  - [F] Incentives are based on NY Sun program and the Section 48 Alternative Energy Investment Tax Credit (ITC) as amended by the Inflation Reduction Act (not available for Strategy 2).
  - [J, K & M] % Emission savings with renewables demonstrates the overall emissions reduction if these projects are implemented and corresponding electrical energy is purchased via a renewable energy source.



## SOLAR PV SYSTEM

Shifting the building’s heating consumption from fossil-fuel natural gas source to electric-source heat pumps is anticipated to result in an increase in electric consumption, which can translate to increased energy costs due to the comparatively higher per-unit cost of electricity over natural gas. One way to mitigate this increase is by incorporating renewable energy systems. Since the Village is in the early stages of roof replacements at the Library and Village Hall, and since the geothermal wellfield will result in major work at the parking lot, there are potentially good opportunities for incorporating solar PV throughout the site.

As the roof is flat, and relatively empty and unobstructed, the Library is likely a good candidate for a rooftop Solar PV array. Due to the amount of HVAC and other service equipment on the Village Hall’s roof, a roof mounted solar array is not recommended at the building, but since the parking lot may be a good candidate for a Solar PV parking canopy. The below diagram shows the size and potential for energy generation of the solar PV systems.

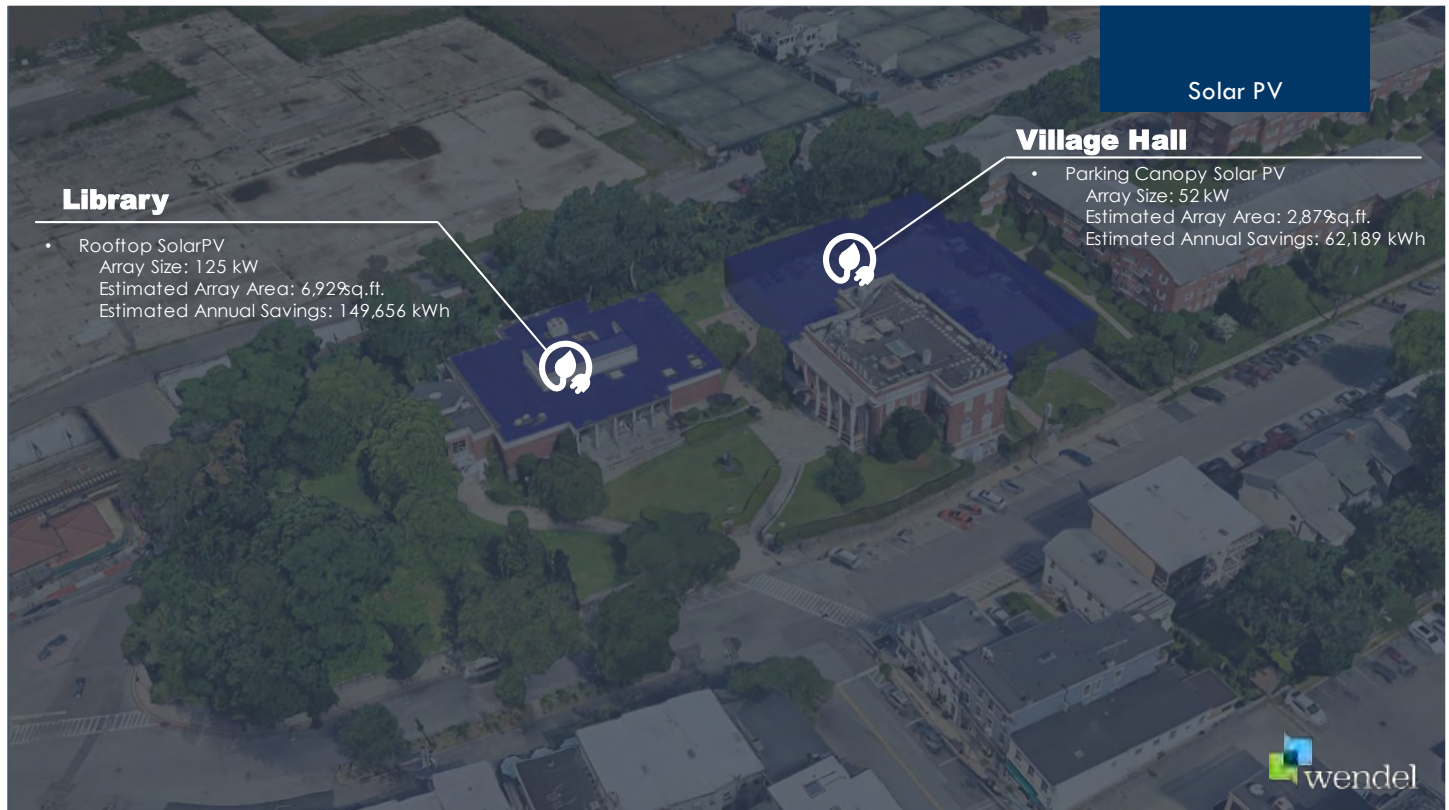

Figure 4. Locations of proposed roof mount and parking canopy solar arrays.

## STRATEGIES NOT PURSUED

Additional Strategies were investigated during early stages of this study, before being deemed unfeasible to develop further. These can be seen below:

Strategy	Reason Strategy Not Pursued
<b>Central Water-to-Water Heat Pump</b>	Early stages of the investigation explored the use of a central water-to-water heat pump to distribute hot and chilled water to both the Village Hall and Library. This strategy was abandoned due to the anticipated impacts and physical space limitations of running the required 4-pipe system through Village Hall. The recommended strategy included in this assessment instead allows for a 2-pipe system.
<b>Central Air-to-Water Heat Pump</b>	Similar to the Central Water-to-Water Heat Pump, a Central Air-to-Water Heat Pump was explored and then ultimately abandoned since it would also require running 4 sets of pipes through the Village Hall (hot water supply, hot water return, chilled water supply, and chilled water return).
<b>Variable Refrigerant Flow</b>	A Variable Refrigerant Flow (VRF) system was considered as a solution to replace the Village Hall’s steam radiators. In the geothermal scenario, these would have been tied into the wellfield for heat

	rejection, and in the air source scenario, rejected to air. VRF systems have limited options for providing outdoor air and generally require a supplemental Dedicated Outdoor Air System (DOAS), which in turn often require ductwork. Due to the difficulty in adding ductwork to the building, this option was abandoned in favor of systems that provide through-the-wall ventilation.
<b>Electric Boiler</b>	This would entail replacing the Village Hall’s fossil fuel steam boiler with an electric steam boiler. Although this option would electrify the building’s heating loads with minimal upgrades to terminal HVAC infrastructure, the implementation would require a significant increase in electrical capacity at the Village Hall and would result in significantly increased energy costs, with significantly lower reduction in carbon emissions in the near-term.

**RECOMMENDED PROJECT**

To achieve long term strategic carbon reduction goals, the Village will need to transition away from fossil fuel energy sources. A ground source heat pump solution paired with a solar PV installation on the Library’s roof can provide a full switch from fossil fuels while leveraging new incentives for renewable energy and providing reduced annual operating costs. This strategy is aligned with the Village’s Climate Action Plan (CAP) Objectives for switching to renewable energy and conserving water.

	<b>Scenario 1 (30% ITC)</b>	<b>Scenario 2 (40% ITC)</b>	
<b>TOTAL COST:</b>	\$2,116,470	\$2,116,470	<b>A</b>
<b>ENERGY COST SAVINGS:</b>	\$37,930	\$37,930	<b>B</b>
<b>OPERATIONAL &amp; MAINTENANCE SAVINGS:</b>	\$602	\$602	<b>C</b>
<b>EMISSIONS SAVINGS:</b>	89	89	<b>D</b>
<b>AVOIDED CAPITAL COST:</b>	\$994,156	\$994,156	<b>E</b>
<b>INCENTIVES &amp; IRA TAX CREDITS:</b>	\$683,891	\$857,812	<b>F</b>
<b>PAYBACK WITH INCENTIVES:</b>	<b>11</b>	<b>7</b>	<b>G*</b>
<b>% ELECTRIFICATION OF HEATING:</b>	100%	100%	<b>H</b>
<b>% ENERGY SAVINGS:</b>	69%	69%	<b>I</b>
<b>% EMISSIONS SAVINGS:</b>	94%	94%	<b>J</b>
<b>% EMISSIONS SAVINGS (w/Full Renewables):</b>	100%	100%	<b>K</b>

- Notes
- **[G]** Payback includes incentives and avoided capital costs.
  - **[F]** Incentives are based on NY Sun program and the Section 48 Alternative Energy Investment Tax Credit (ITC) as amended by the Inflation Reduction Act. Two incentive scenarios are provided for analysis, one using 30% of the project cost of geothermal equipment and the other adding the 10% Domestic Content provision for a total of 40% of the cost. In both Scenarios, the ITC for Solar PV is estimated at 30% of the Solar PV system cost, due to the limitations of US-produced Solar PV.
  - **[K]** % Emission savings with renewables demonstrates the overall emissions reduction if these projects are implemented and corresponding electrical energy is purchased via a renewable energy source.

The following Total Project Summaries show the anticipated energy and financial impacts of the recommended project scenario. We have included a Summary page each for Scenario 1 (30% ITC for geothermal and solar) and Scenario 2 (40% ITC for geothermal and 30% ITC for solar).



**Village of Hastings-on-Hudson Geothermal Feasibility  
TOTAL PROJECT SUMMARY  
7/18/2023  
Comprehensive Project - 30% Geothermal ITC Subsidy**

(Y)es (N)o (O)ption	Line No.	Facility	Energy Conservation Measure	Total Measure Cost <sup>1</sup> (\$)	Annual Electric Savings (kWh)	Annual Fuel Savings (mmBtu)	Annual O&M Savings (\$)	Annual Electric Savings (\$)	Annual Fuel Savings (\$)	Total Annual Savings (\$)	Payback with Incentive <sup>2</sup>	Emissions Reduction (Metric Tons of CO <sub>2</sub> )	Avolded Capital Cost <sup>3</sup>	Estimated Total Incentive <sup>4</sup>
Y	1	Village of Hastings-on-Hudson	Geothermal Heat Pump System	\$1,739,213	-123,482	1,536	\$1,849	-\$27,043	\$32,197	\$7,004	31.9	48.1	\$994,156	\$521,764
N	2	Village of Hastings-on-Hudson	Air Source Heat Pump System	\$912,038	-140,149	1,536	\$2,329	-\$30,693	\$32,197	\$3,834	-4.8	43.6	\$930,490	\$0
N	3	Village of Hastings-on-Hudson	Village Hall Parking Lot Parking Canopy PV	\$313,534	62,189	0	-\$518	\$13,619	\$0	\$13,101	16.4	16.8	\$0	\$98,465
Y	4	Village of Hastings-on-Hudson	Library Rooftop Solar PV	\$377,257	149,656	0	-\$1,247	\$32,775	\$0	\$31,528	6.8	40.5	\$0	\$162,127
<b>PROGRAM TOTALS - Recommended Measures</b>				<b>\$2,116,470</b>	<b>26,174</b>	<b>1,536</b>	<b>\$602</b>	<b>\$5,732</b>	<b>\$32,197</b>	<b>\$38,532</b>	<b>11.4</b>	<b>88.6</b>	<b>\$994,156</b>	<b>\$683,891</b>

**NOTES:**

- TOTAL MEASURE COST includes direct construction costs (subcontractor material and labor) and DOES include fees for services described below:  
Energy, Electrical and Mechanical engineering, Construction documents, Financing assistance services, Subcontractor coordination and administration
- PAYBACK WITH INCENTIVE includes incentives and avoided capital costs.
- Avolded Capital Cost is inclusive of a steam boiler replacement at Village Hall, new Steam-to-HW HX to serve the Library, a new air cooled chiller at the Library, a renovation of the existing terminal HVAC units at Village Hall. Scenario 1.1 includes the additional cost to repave the Village Hall parking lot.
- ESTIMATED TOTAL INCENTIVE is currently estimated using 30% of net project costs from the Inflation Reduction Act Section 48 Tax Credits for Solar PV & Geothermal Scenarios, \$1.00/W from NY Sun for ConEdison's Region. This is not included in the Total Measure Cost. These values represent the best estimates of future incentives and are subject to change. Please refer to the report for details.



**Village of Hastings-on-Hudson Geothermal Feasibility  
TOTAL PROJECT SUMMARY  
7/18/2023  
Comprehensive Project - 40% Geothermal ITC Subsidy**

(Y)es (N)o (O)ption	Line No.	Facility	Energy Conservation Measure	Total Measure Cost <sup>1</sup> (\$)	Annual Electric Savings (kWh)	Annual Fuel Savings (mmBtu)	Annual O&M Savings (\$)	Annual Electric Savings (\$)	Annual Fuel Savings (\$)	Total Annual Savings (\$)	Payback with Incentive <sup>2</sup>	Emissions Reduction (Metric Tons of CO <sub>2</sub> )	Avolded Capital Cost <sup>3</sup>	Estimated Total Incentive <sup>4</sup>
Y	1	Village of Hastings-on-Hudson	Geothermal Heat Pump System	\$1,739,213	-123,482	1,536	\$1,849	-\$27,043	\$32,197	\$7,004	7.0	48.1	\$994,156	\$695,685
N	2	Village of Hastings-on-Hudson	Air Source Heat Pump System	\$912,038	-140,149	1,536	\$2,329	-\$30,693	\$32,197	\$3,834	-4.8	43.6	\$930,490	\$0
N	3	Village of Hastings-on-Hudson	Village Hall Parking Lot Parking Canopy PV	\$313,534	62,189	0	-\$518	\$13,619	\$0	\$13,101	16.4	16.8	\$0	\$98,465
Y	4	Village of Hastings-on-Hudson	Library Rooftop Solar PV	\$377,257	149,656	0	-\$1,247	\$32,775	\$0	\$31,528	6.8	40.5	\$0	\$162,127
<b>PROGRAM TOTALS - Recommended Measures</b>				<b>\$2,116,470</b>	<b>26,174</b>	<b>1,536</b>	<b>\$602</b>	<b>\$5,732</b>	<b>\$32,197</b>	<b>\$38,532</b>	<b>6.9</b>	<b>88.6</b>	<b>\$994,156</b>	<b>\$857,812</b>

**NOTES:**

- TOTAL MEASURE COST includes direct construction costs (subcontractor material and labor) and DOES include fees for services described below:  
Energy, Electrical and Mechanical engineering, Construction documents, Financing assistance services, Subcontractor coordination and administration
- PAYBACK WITH INCENTIVE includes incentives and avoided capital costs.
- Avolded Capital Cost is inclusive of a steam boiler replacement at Village Hall, new Steam-to-HW HX to serve the Library, a new air cooled chiller at the Library, a renovation of the existing terminal HVAC units at Village Hall. Scenario 1.1 includes the additional cost to repave the Village Hall parking lot.
- ESTIMATED TOTAL INCENTIVE is currently estimated using 30% of net project costs from the Inflation Reduction Act Section 48 Tax Credits for Solar PV and 40% for Geothermal Scenarios, \$1.00/W from NY Sun for ConEdison's Region. This is not included in the Total Measure Cost. These values represent the best estimates of future incentives and are subject to change. Please refer to the report for details.





**ALTERNATE PROJECT**

The alternate project not recommended consists of the Air Source Heat Pump (ASHP) presented in Strategy 2, paired with the Library Solar Rooftop PV. This project will provide similar electrification of heating and solar PV energy generation, but the energy efficiency of the air source system will be lower and is expected to result in higher operating costs. While this project is anticipated to have less upfront costs, the available incentives are significantly lower as the ASHP and subsequent required building HVAC system upgrades are ineligible for the Section 48 ITC. Similarly basing the system on Air Source HPs instead of Geothermal HPs may impact the Village’s eligibility for additional grant funding that prioritizes geothermal and renewables over other less-energy efficient technologies.

	<b>Probable Cost (Alternate Project)</b>	
<b>TOTAL COST:</b>	\$1,289,294	<b>A</b>
<b>ENERGY COST SAVINGS:</b>	\$34,279	<b>B</b>
<b>OPERATIONAL &amp; MAINTENANCE SAVINGS:</b>	\$1,082	<b>C</b>
<b>EMISSIONS SAVINGS:</b>	84	<b>D</b>
<b>AVOIDED CAPITAL COST:</b>	\$930,490	<b>E</b>
<b>INCENTIVES &amp; IRA TAX CREDITS:</b>	\$162,127	<b>F</b>
<b>PAYBACK WITH INCENTIVES:</b>	6	<b>G*</b>
<b>% ELECTRIFICATION OF HEATING:</b>	100%	<b>H</b>
<b>% ENERGY SAVINGS:</b>	67%	<b>I</b>
<b>% EMISSIONS SAVINGS:</b>	90%	<b>J</b>
<b>% EMISSIONS SAVINGS (w/Full Renewables):</b>	100%	<b>K</b>

- Notes**
- **[G]** Payback includes incentives and avoided capital costs.
  - **[F]** Incentives are based on NY Sun program and the Section 48 Alternative Energy Investment Tax Credit (ITC) as amended by the Inflation Reduction Act. This includes \$1.00/Watt from NY SUN as well as 30% of the remaining cost from the ITC for the Solar PV project. There are no estimated incentives available for the ASHP project.
  - **[K]** % Emission savings with renewables demonstrates the overall emissions reduction if these projects are implemented and corresponding electrical energy is purchased via a renewable energy source.

The following Total Project Summary shows the anticipated energy and financial impacts of the alternate project scenario.

**Village of Hastings-on-Hudson Geothermal Feasibility  
TOTAL PROJECT SUMMARY  
7/18/2023  
Comprehensive Project - Air Source and Library PV Only**

(Y)es (N)o (O)ption	Line No.	Facility	Energy Conservation Measure	Total Measure Cost <sup>1</sup> (\$)	Annual Electric Savings (kWh)	Annual Fuel Savings (mmBtu)	Annual O&M Savings (\$)	Annual Electric Savings (\$)	Annual Fuel Savings (\$)	Total Annual Savings (\$)	Payback with Incentive <sup>2</sup>	Emissions Reduction (Metric Tons of CO <sub>2</sub> )	Avoided Capital Cost <sup>3</sup>	Estimated Total Incentive <sup>4</sup>
N	1	Village of Hastings-on-Hudson	Geothermal Heat Pump System	\$1,739,213	-123,482	1,536	\$1,849	-\$27,043	\$32,197	\$7,004	31.9	48.1	\$994,156	\$521,764
Y	2	Village of Hastings-on-Hudson	Air Source Heat Pump System	\$912,038	-140,149	1,536	\$2,329	-\$30,693	\$32,197	\$3,834	-4.8	43.6	\$930,490	\$0
N	3	Village of Hastings-on-Hudson	Village Hall Parking Lot Parking Canopy PV	\$313,534	62,189	0	-\$518	\$13,619	\$0	\$13,101	16.4	16.8	\$0	\$98,465
Y	4	Village of Hastings-on-Hudson	Library Rooftop Solar PV	\$377,257	149,656	0	-\$1,247	\$32,775	\$0	\$31,528	6.8	40.5	\$0	\$162,127
<b>PROGRAM TOTALS - Recommended Measures</b>				<b>\$1,289,294</b>	<b>9,507</b>	<b>1,536</b>	<b>\$1,082</b>	<b>\$2,082</b>	<b>\$32,197</b>	<b>\$35,362</b>	<b>5.6</b>	<b>84.1</b>	<b>\$930,490</b>	<b>\$162,127</b>

**NOTES:**

- TOTAL MEASURE COST includes direct construction costs (subcontractor material and labor) and DOES include fees for services described below:  
Energy, Electrical and Mechanical engineering, Construction documents, Financing assistance services, Subcontractor coordination and administration
- PAYBACK WITH INCENTIVE includes incentives and avoided capital costs.
- Avoided Capital Cost is inclusive of a steam boiler replacement at Village Hall, new Steam-to-HW HX to serve the Library, a new air cooled chiller at the Library, a renovation of the existing terminal HVAC units at Village Hall. Scenario 1.1 includes the additional cost to repave the Village Hall parking lot.
- ESTIMATED TOTAL INCENTIVE is currently estimated using 30% of net project costs from the Inflation Reduction Act Section 48 Tax Credits for Solar PV & Geothermal Scenarios, \$1.00/W from NY Sun for ConEdison's Region. There is no estimated incentive available for the Air Source HP option. This is not included in the Total Measure Cost. These values represent the best estimates of future incentives and are subject to change. Please refer to the report for details.







# section b

---

existing system

## EXISTING SYSTEM

### OVERVIEW

The Village Hall and Library's existing infrastructure provides the following opportunities for conversion to a fully electrified heating system:

- Available electrical capacity associated with replacing the Library's air-cooled chiller and Village Hall's PTAC units
- Critical HVAC infrastructure that will compliment a heat pump system
  - Hot water and chilled water heating and cooling at the Library – these systems can be tied into a hot water/chilled water heat pump loop
  - DX cooling systems for process loads (server/IT rooms) at Village Hall – these systems can be converted into a central loop for constant cooling sources which maximize “free” energy recovery.
- Critical HVAC infrastructure at the Village Hall that is at the end of its useful life and will need to be replaced or undergo major repairs
- Electric Domestic Hot Water heaters – removing steam from the buildings will not impact DHW systems

The existing infrastructure provides the following constraints that will need to be addressed to allow for conversion to a fully electrified heating system.

- Steam heating system – a centralized steam boiler provides steam for the Village Hall's steam radiators and for the Library's hot water heating (via a steam-to-hot water heat exchanger)
- Steam Boiler [**END OF LIFE**]
- Steam radiators [**END OF LIFE**]
- Limited electrical capacity
  - Village in process of adding a new 400A service to allow for new Level 2 Electric Vehicle chargers. The Village has estimated that 150 Amps will remain as spare capacity.
- Limited physical space for new equipment
- Much of the Village Hall is uncooled or utilizes DX equipment, and these would be converted to chilled water cooling
- Ventilation – Many areas at Village Hall are not currently ventilated, and if doing a major HVAC upgrade, best practice would be to add outdoor air supply in those areas for occupant safety and comfort
- Emergency back-up system – preliminary strategy will be to use existing and planned expansions to emergency generators, and/or new condensing hot water boilers to back-up the system during a power outage. Currently, most emergency generator options are fossil fuel based.
- Although partial abatement projects have been done around the steam system and radiators, Hazardous Materials likely remain in Village Hall

The following is an overview of the major systems and equipment at the Village Hall and Library. See Appendix 2 for a detailed inventory of existing building systems.

### HEATING SYSTEM SUMMARY

The majority of the Village Hall and Library's heating is provided by one (1) 2,452 MBH Weil McLain Steam Boiler located in the Village Hall's basement mechanical room. The boiler is dual fuel but typically runs exclusively on natural gas. Steam generated at the boiler is distributed to the steam radiators serving the majority of the Village Hall's perimeter spaces and is also converted via a steam-to-hot water heat exchanger housed in Village Hall to provide the hot water supplied to the Air Handling Unit and radiators serving the Library's main space. A second hot water loop connecting fin tubes in the Village Hall's police locker room exists but is out of service. There are no reheat systems in the buildings, and the boiler will shut down in the summer, whereupon the buildings will have no natural gas usage. There are also split heat pump units serving the Police Area in the Village Hall, as well as the community room and office in the Library.





Figure 5. Heating systems at the Village Hall and Library

### COOLING SYSTEM SUMMARY

Village Hall also contains a rooftop Air Handling Unit (AHU) serving the courtroom, and a mix of DX split units and Packaged Terminal Air Conditioners (PTACs) to provide cooling to select areas. Cooling at the Library is provided by one (1) 40 Ton Trane Air-Cooled scroll chiller that was installed in the 1990s, which provides chilled water to the AHU serving the main floor area. The library also contains three (3) split DX heat pumps serving the offices and community room.



Figure 6. Cooling systems at the Village Hall and Library



### CONTROLS SYSTEM SUMMARY

The Library's AHU and chilled/hot water systems are on a BMS system managed by Automated Control Logic that allows for scheduling of the systems. Heating at Village Hall is controlled via two wall-mounted programmable thermostats, which set the schedule and temperature for broad ranges of areas within the building. Unlike the rest of the building, the section occupied by the police operates 24/7, leading to areas of the building being heated when occupied. Cooling is controlled by in-unit thermostats.



Figure 7. HVAC terminal systems at the Village Hall and Library

### DOMESTIC HOT WATER SYSTEM SUMMARY

The Village Hall and Library's Domestic Hot Water is generated by electric resistance hot water storage heaters. No recommendations for system updates were included in this study.



Figure 8. Domestic Hot Water systems at the Village Hall and Library



## BUILDING ENVELOPE SUMMARY

The Village Hall is an 8" Concrete Block structure with exterior brick and single-pane operable windows. It contains a built-up metal deck roof with ~2" rigid insulation and gravel. The roof and parts of the exterior walls received renovation in 1998.

The Library's exterior walls are 6" concrete block with exterior brick, and the windows are single pane. The roof is a concrete built up system with 1.5" of rigid insulation.

Both the Library and Village Hall are currently slated for roof replacements. It is anticipated that these roofs would be designed to at minimum NYStretch Energy Code, which the Village was an early leader in adopting, which could lead to reduced heating loads.

## LIGHTING SYSTEM SUMMARY

Lighting throughout the Village Hall and Library is predominantly LED-based, completed as part of a municipal wide lighting upgrade in 2016.

## ELECTRICAL SYSTEM SUMMARY

Village Hall receives 400A electric service supplied from the street-level transformer. The Village has been installing L2 car chargers for EVs, and are in the process of adding 2-3 more. This installation is being paired with an additional 400A electric service increase, and it is anticipated that the new EV chargers will account for 250A of that new 400A service. The Library independently receives a 600 Amp electric service.

The Village Hall also has a 75kW generator with Automatic Transfer Switch (ATS) which serves the police station and the rest of the building, excluding the elevators and 2nd floor Air Conditioners. The Village is also in the process of upgrading this into a 125kW service. The Library has no emergency electric backup.



Figure 9. Electric systems at the Village Hall and Library

## HAZARDOUS MATERIALS

Due to the age of the building, it is very much anticipated that the Village Hall will require hazardous material abatement in areas should it undergo any major renovations. While the facility has abated asbestos related to steam piping and radiators, it is anticipated that any new floor/wall penetrations may encounter hazardous materials.



# section c

---

energy usage



## ENERGY USAGE

This section outlines data sources for existing energy usage, analysis procedure for thermal modeling of building heating and cooling loads, utility rate modeling and emissions calculations. Calendar year 2022 is used as the basis for load and utility rate modeling. Data limitations are noted in each subsection.

### ELECTRIC UTILITY

The Village Hall and Library’s electric utilities are provided by New York Power Authority (NYPA). Each building has its own meter and account, and both accounts are billed according to NYPA’s GOV\_WES\_69 service classification.

#### Assessment of Data

- Library energy usage shows a clear weather dependent pattern indicating cooling associated with the electric utility source.
- Village Hall energy usage shows a minor correlation with weather indicating very little cooling associated with the electric utility source.

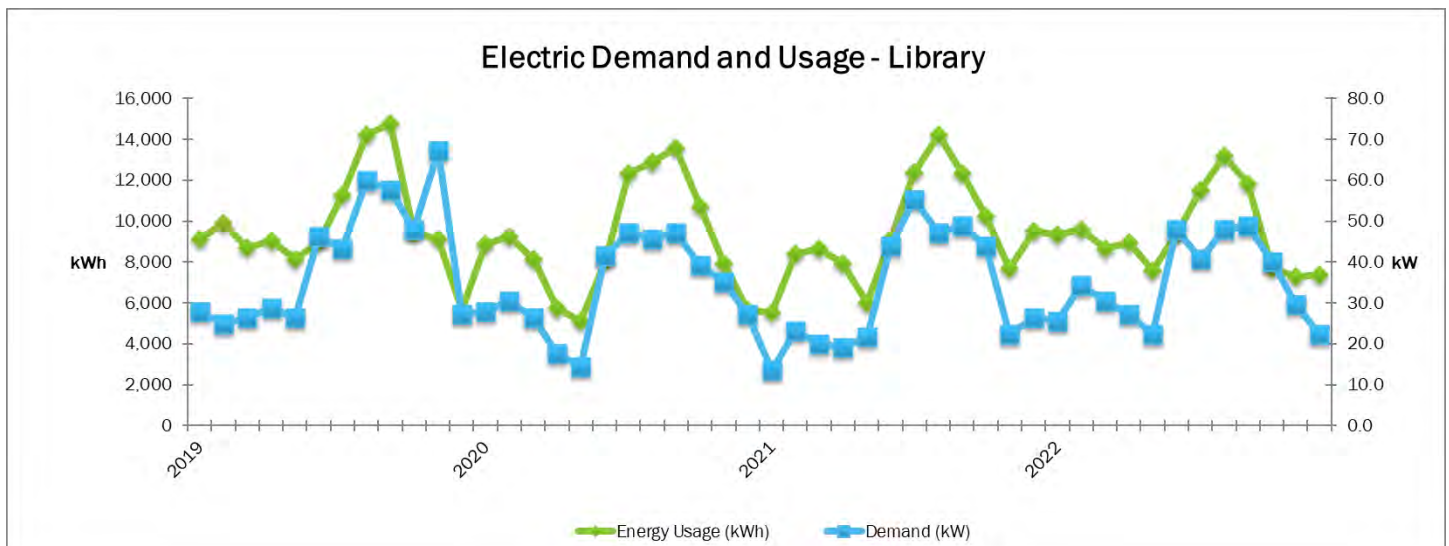
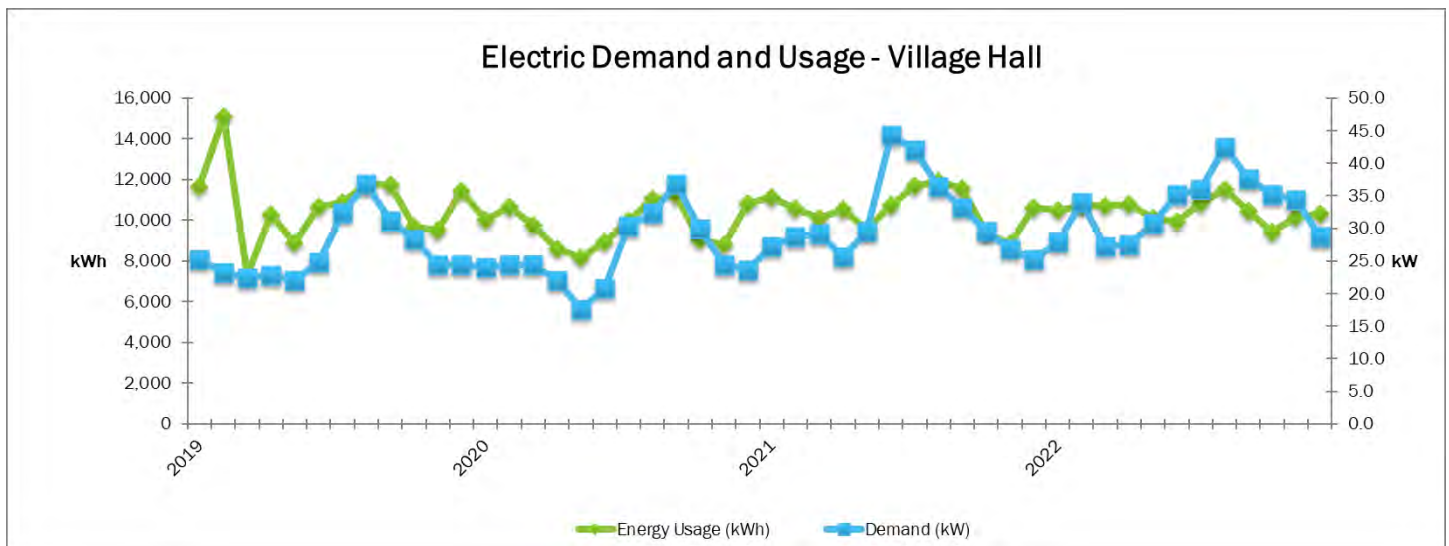



### NATURAL GAS UTILITY

The Village Hall and Library share one natural gas meter. Natural Gas is used only to generate steam at the boiler plant used for heating at the Village Hall and hot water heating at the Library via a steam-to-hot water heat exchanger. Natural gas is supplied and delivered by ConEdison.

#### Assessment of Data

- Natural Gas Energy usage is 0 during the summer months. This is expected since the facility does not have reheats and DHW is electric-source. Furthermore, the facility has confirmed that the boilers are switched off during the cooling season.
- The facility has reported fuel oil is used for backup, but no fuel oil was consumed throughout 2022.

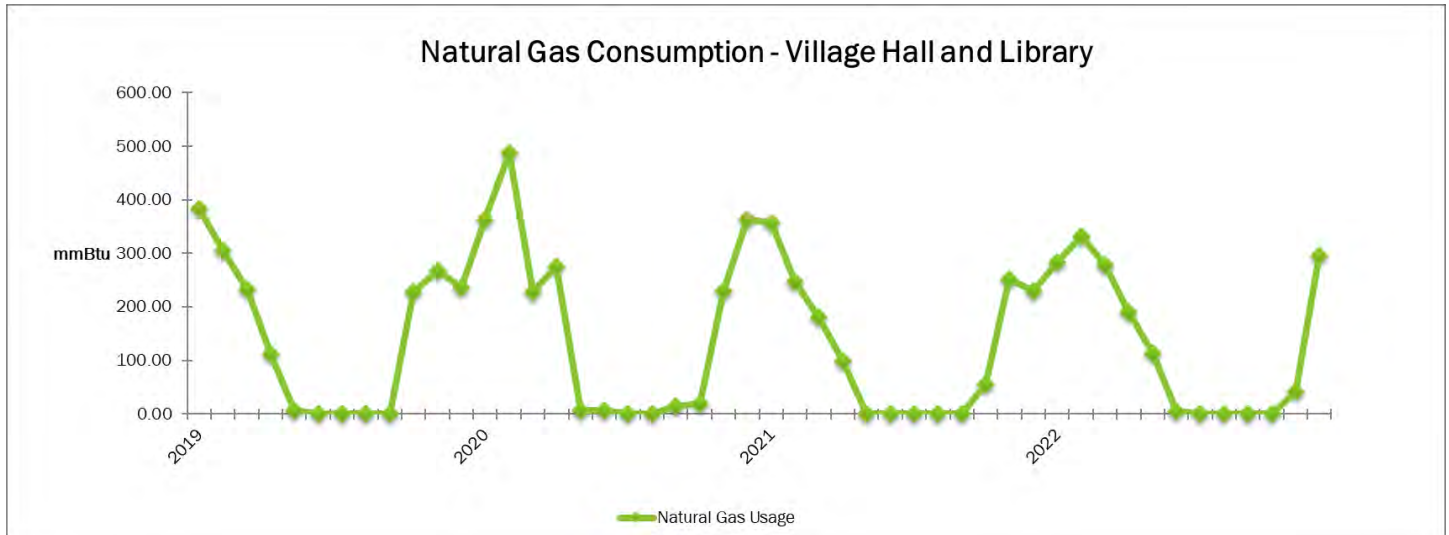

**BUILDING ENERGY END USE**

**Energy Consumption by System - Village Hall**

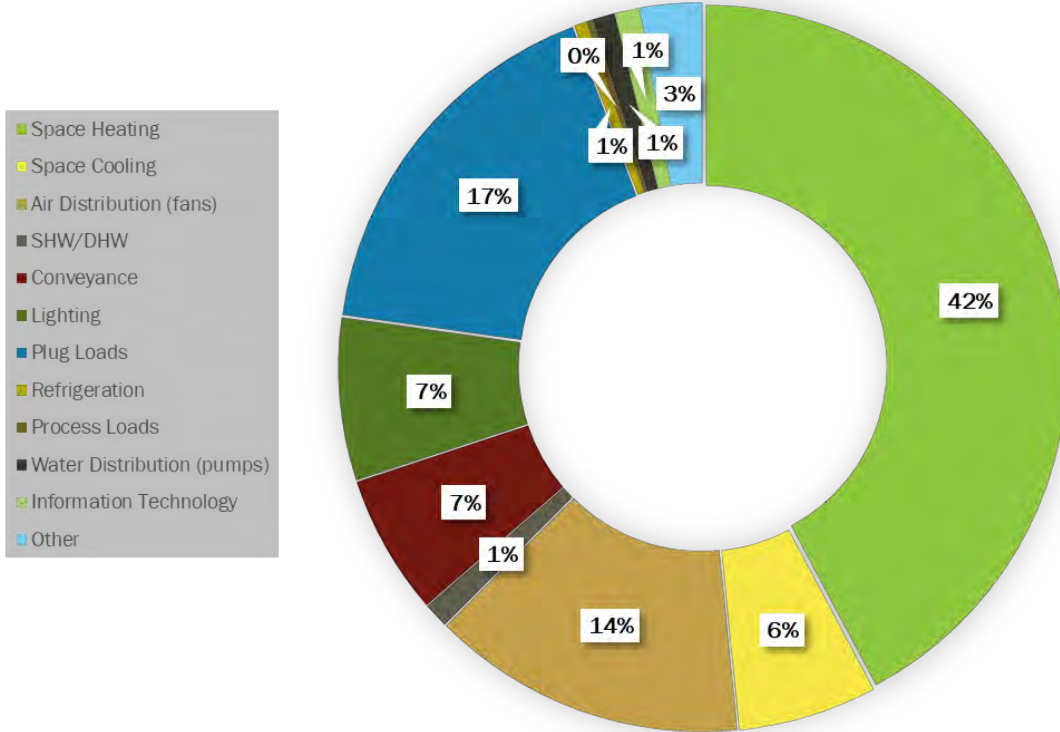

**Energy Consumption by System - Library**

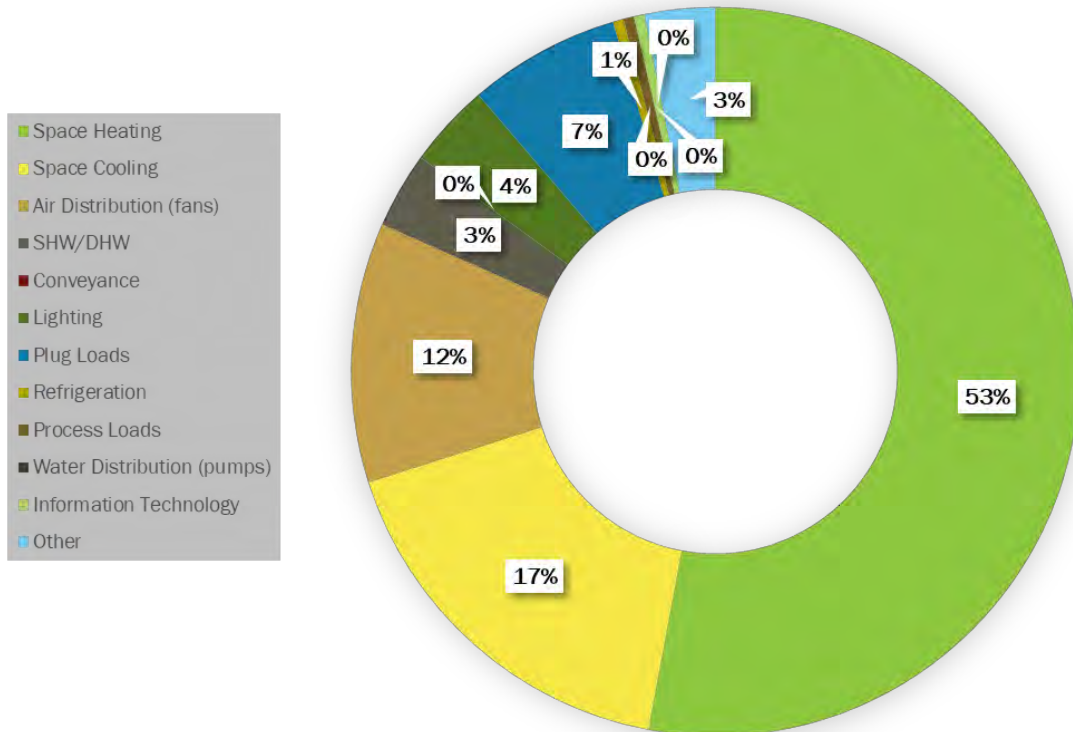

**UTILITY & EMISSIONS SUMMARY**

The following table summarizes the energy usage for the two buildings. Please note the following:

- Utility usages and costs based on 2022
- Emissions factors source: eGRID 2020

	Year	Annual Energy Usage	Demand (kW)		Cost	Blended Rate <sup>1</sup>	Rate <sup>2</sup>		Emissions MT CO2e
			Peak	Annual			Usage	Demand	
Electric	2022	237,800 kWh	90	815	\$51,954	\$0.22	N/A	N/A	13
Natural Gas	2022	15,363 therms	N/A	N/A	\$32,197	\$2.10	N/A	N/A	81
Model YR Electric	Base	237,800 kWh	90	815	\$51,954	\$0.22	N/A	N/A	13
Model YR Natural Gas	Base	15,363 therms	N/A	N/A	\$32,197	\$2.10	N/A	N/A	81
<b>Total</b>	Base	2,348 mmBtu	N/A	N/A	\$84,152	\$35.84	N/A	N/A	94

<sup>1</sup> Blended rate based on total cost ÷ usage

<sup>2</sup> Rate separates demand cost and usage costs

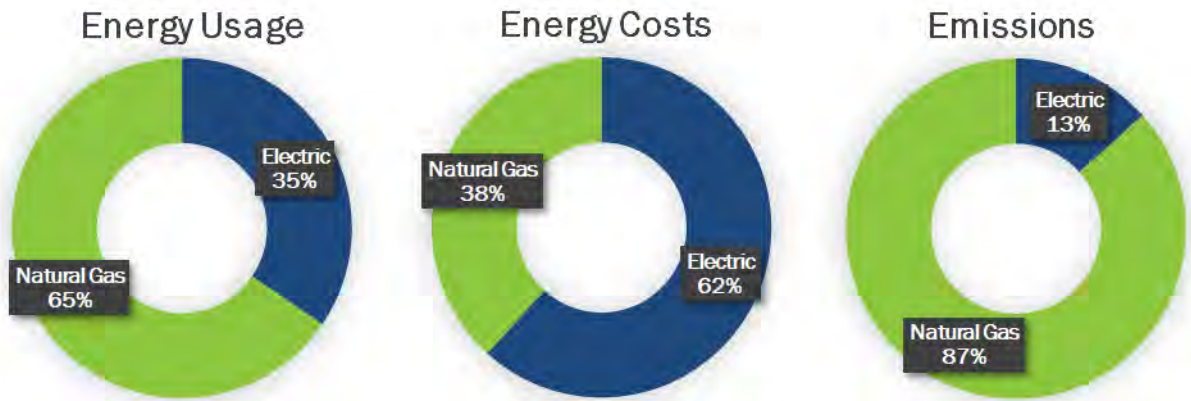

Natural Gas	116.98	lbs CO2 / mmBtu
Electric	596.40	lbs CO2 / MWh
Conversion	0.000454	Metric Tons / Lbs





# section d

---

thermal loading

# THERMAL LOADING

## HEATING LOADS

Heating loads are modeled based on the natural gas usage. Please note the following adjustments:

- **Domestic Hot Water:** Domestic hot water is electric-source and not produced from a Natural Gas utility, as confirmed by interviews and site visits.
- **Humidification:** Based on the building type, loading profile and site visit observations, it was determined that humidification is not used.
- **Steam Sterilization:** Based on the building type, loading profile and site visit observations, it was determined that there are no steam sterilization end-uses.
- **Efficiency:** Boiler plant evaluated at 79% efficiency based on nameplate data. Building loads are calculated as follows:

$$\text{Natural Gas Usage (as reported)} \times 79\% = \text{Building Thermal Heating Load (Units as reported)}$$

Hourly load profiles are estimated by using a quadratic regression analysis and the following procedure:

- Hourly weather data collected from via NOAA Local Climatological Data
- Monthly Utility data collected from the Client
- Heating and Cooling Degree Days collected from NOAA or NYSERDA
- A quadratic model is compiled correlating outdoor air temperature to energy usage.
- Adjustment factors are used to tune the model to account for total annual usage, summer usage and peak usage.
- Peak usage is backchecked for reasonableness based on rule of thumb peak heating load of 20 to 40 btu/sqft.

Heat Recovery and Geothermal | Heating Potential

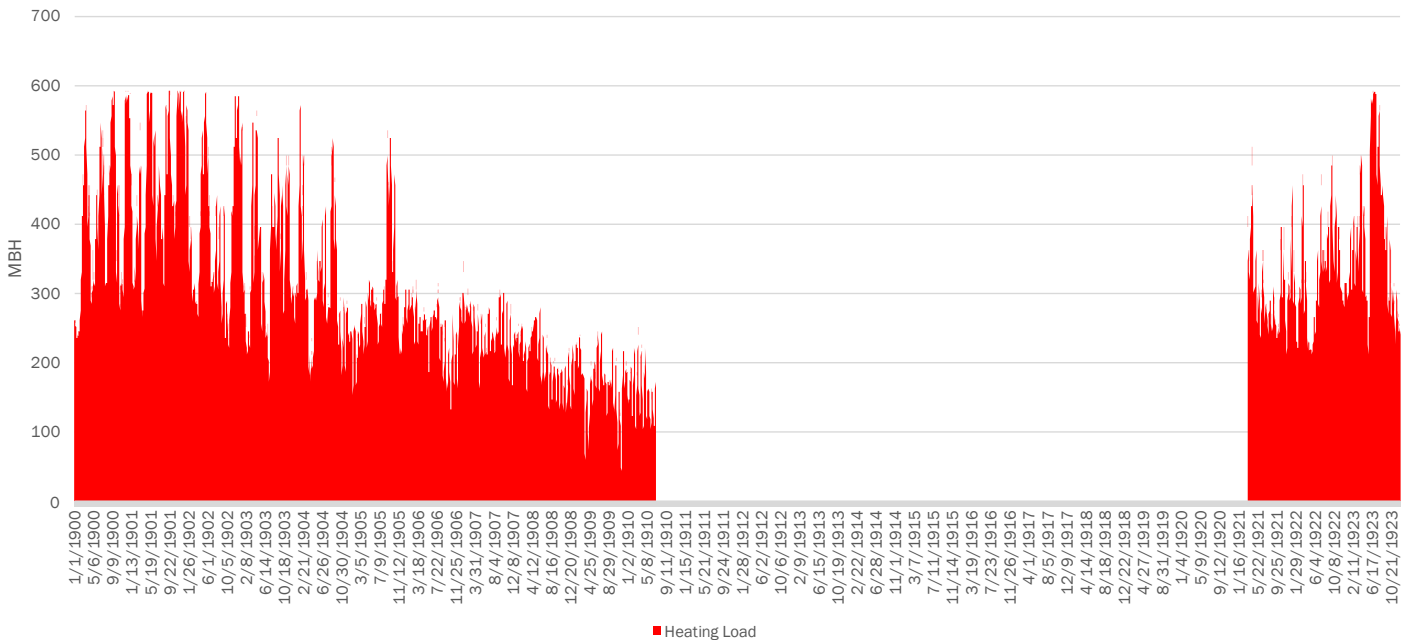

Figure 10. Graph of hourly thermal load model (heating)

## COOLING LOADS

Cooling loads are modeled based on the electrical usage. Please note the following adjustments:

- **Weather Dependent Loading:** Electrical loads are comprised of several different end-uses such as lighting, plug loads, pumps, and fans. While weather may impact all of these, cooling loads associated with chilled water and DX systems are the largest weather dependent electrical load.
- **Plant Efficiency:** Chiller plant and/or other cooling equipment is assumed to have an efficacy of 1.17 kW/Ton. Weather dependent Building loads are calculated as follows:

$$\text{Weather Dependent Electrical Usage (as reported)} \div 1.17 \text{ kW/Ton} = \text{Thermal Cooling Load (Ton-Hours)}$$

Heat Recovery and Geothermal | Cooling Potential

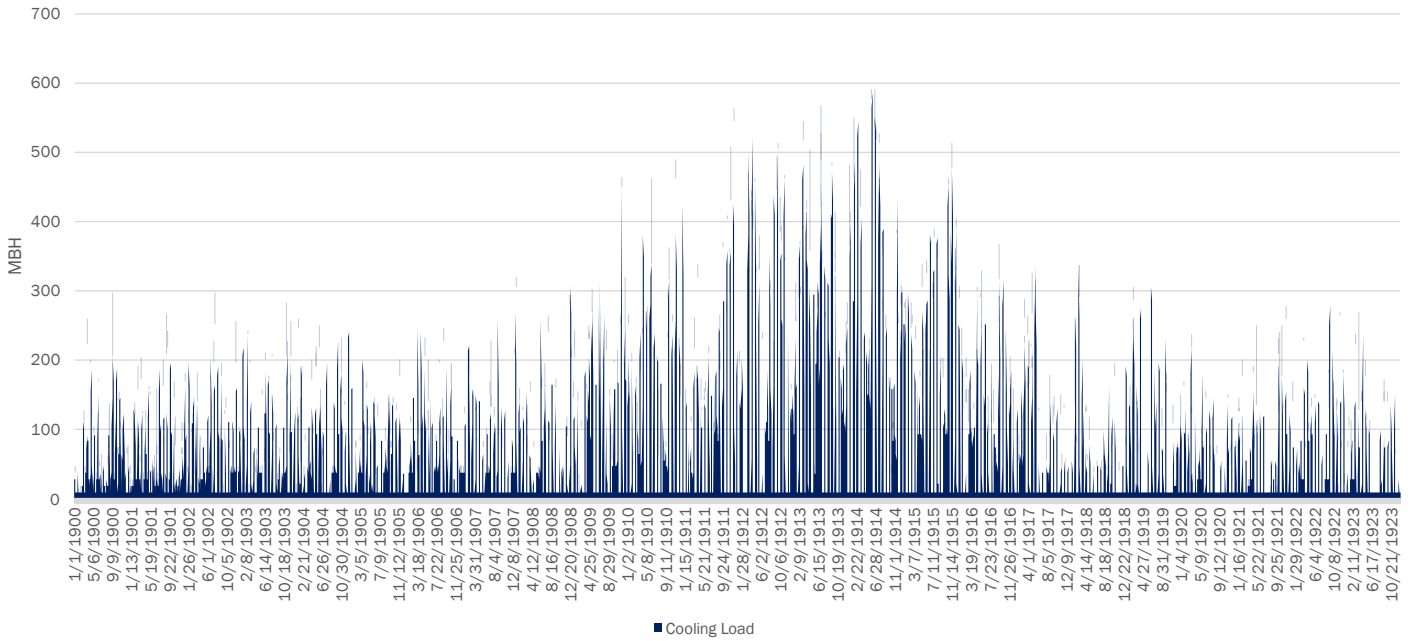

Figure 11. Graph of hourly thermal load model (cooling)

The following chart shows the combined heating and cooling loads overlaid to highlight the potential for heat recovery in both proposed Strategies.

Heat Recovery and Geothermal | Combined Heating and Cooling Potential

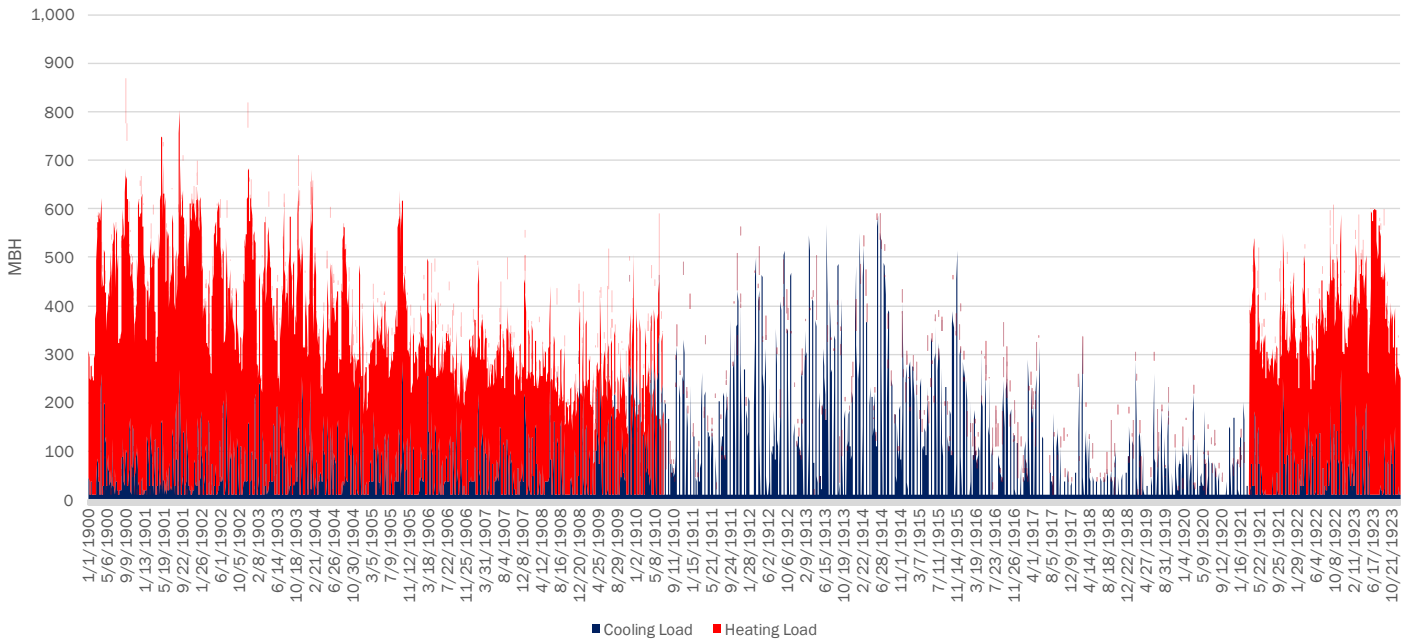

Figure 12. Graph showing combined heating and cooling loading





# section e

---

proposed system

## PROPOSED SYSTEM

### GEOTHERMAL HEAT PUMP SYSTEM

	Library	Village Hall
HEAT PUMP TYPE	Modular 10-ton units	Terminal WSHPs
NUMBER OF HEAT PUMPS	4 Modules	(43) 0.75 Ton, & (5) 1.50 Ton
HEAT PUMP OPERATING TEMPERATURES	CHW:45/55; HW:140/120; Ground loop: 55/75	
WELLFIELD	20 Wells at 2.5 Tons per well (assumed)	
WELLFIELD AREA	13,850 sqft	
ELECTRIC SAVINGS	-123,488 kWh	
NATURAL GAS SAVINGS	1,536 mmBTU	
TOTAL EMISSIONS SAVINGS	48 MT CO2	

The proposed system will feature a central Heat Pump sized to match the cooling load for the Library, and terminal heat pumps sized to match existing heating loads at the Village Hall’s individual rooms. The central heat pump will be located on the rooftop of the Library in place of the existing 40 Ton air-cooled chiller, and the terminal units will be in place of the existing radiators at the Village Hall. The heat pump will all be connected via a neutral temperature loop that absorbs/rejects heat to a geothermal wellfield, and the central heat pump will then distribute hot water and chilled water to the Library’s AHU and radiators. A high-level schematic of this system can be seen in Appendix 4.



Figure 13. Sample proposed Central Heat Pump to replace Library chiller

### CHILLED AND HOT WATER SYSTEMS

The Library’s chilled water distribution system will be connected to the Central Heat Pump at the existing connection point, and the hot water distribution system will be connected to the Central Heat Pump via new pumps and roughly 50’ of piping. The Hot Water pumps are sized for:

1. **Maximum Flow Rate:** Library HW system
2. **Pressure Drop:** Assumed maximum hot water distribution system ΔP.

### TERMINAL SYSTEMS

The Village Hall’s radiators and PTACs will be replaced with individual through-the-wall WSHP units. The units will have the capability to provide outdoor air, individual unit and/or central DDC controls.

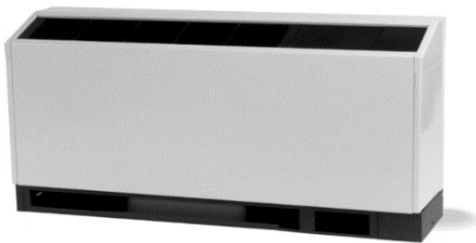

Figure 14. Sample proposed WSHP terminal units for Village Hall

### NEUTRAL TEMPERATURE DISTRIBUTION

The neutral temperature distribution system will connect to the Central Heat Pump, the Village Hall’s terminal WSHP units, and the geothermal wellfield via an estimated pipe length of 160’. An estimated 530’ of neutral temperature piping will be run throughout the perimeter of the Village Hall to connect the terminal WSHP units.

### GEOTHERMAL LOOP

A Geothermal Loop, assumed to be 30% glycol, will be connected to the neutral temperature loop at one connection point, a plate and frame heat exchanger. The plate and frame will be connected to the neutral temperature systems via pressure independent control valves. A two-position, three-way valve will connect the chilled water, hot water, and plant side of the central heat pump. The plate and frame heat exchanger will be sized based on the anticipated maximum capacity of the well field. The secondary ground loop pumps are sized as follows:

1. **Maximum Flow Rate:** the ground loop
2. **Pressure Drop:** Assumed maximum ground loop system ΔP.



**GEOHERMAL WELLFIELD**

	<i>Wellfield Location</i>	<i>Wellfield Type</i>	<i>Spacing</i>	<i>Depth</i>	<i>Assumed Capacity</i>
Geothermal Wellfield	Village Hall Parking Lot	Vertical, Closed-loop	20'	500'	2.5 tons/well

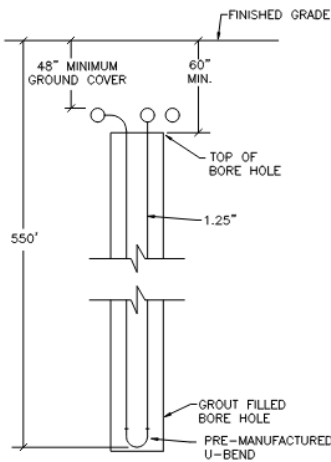

Figure 15. Sample diagram of a geothermal borehole

The Well Field is anticipated to be a Vertical loop system consisting of a series of “u-shaped” pipes installed in drilled bores. Vertical and angled wells are typically installed to a maximum depth of 500ft in NY state. The pipes are grouted into the wells and connected by horizontal circuit piping. Each circuit will typically contain 10 to 15 wells, with circuits connecting back to a valve box. Wells need to be positioned approximately 20’ apart to avoid creating permafrost conditions. These systems typically require 175 to 250 linear feet per ton of cooling.

Bore holes for wells would be drilled at approximately 8 inches in diameter to a depth of 500 ft. Piping with pre-manufactured “U” bends would be utilized in each bore hole and grouted into place. The well field will be divided into circuits with approximately 10 to 15 wells per circuit. Each circuit would require a trench for horizontal piping which would string the circuit together in series.

The circuit trenches would run back into valve vaults, which can be buried in the parking lot or in the mechanical room. Likely one vault would be utilized to tie in all well field circuits. The valves would be controlled in order to allow for modulation of the multiple valved zones.

Prior to construction, drilling of a test well is recommended. A test well will allow for testing of soil conditions and site-specific geology. This would also allow for a conductivity test to be conducted to get a better understanding of the geothermal well capacity. At this time, a thermal conductivity of 2.5 tons / vertical well has been assumed. A test well would be recommended to get a representative sample of the proposed well field.

**GEOLOGIC REVIEW**

Wendel worked with a geothermal drilling consultant, Brightcore, for a high-level review of the geologic conditions.

The site is located on Inwood Marble bedrock, a type of hard bedrock favorable for borehole well drilling. The depth to bedrock varies from between surface to approximately 40 feet below ground level. The site is located ~1,200 ft from city water tunnel #3 and is clear of the 500 ft water tunnel infrastructure corridor. A pollution control interceptor sewer runs parallel to the edge of the Hudson River which is about 200 ft from the site. Generally, this type of infrastructure is relatively shallow, and setbacks are determined on a case-by-case basis. This site appears to be sufficiently setback from sewer interceptors. The nearest MTA infrastructure is within 100 feet of the site. If the project were to be constructed, formal project review from the MTA would need to be requested, if the MTA reviews the project and determines that the work may have adverse impacts due to vibrations, a vibration monitoring plan may be required.

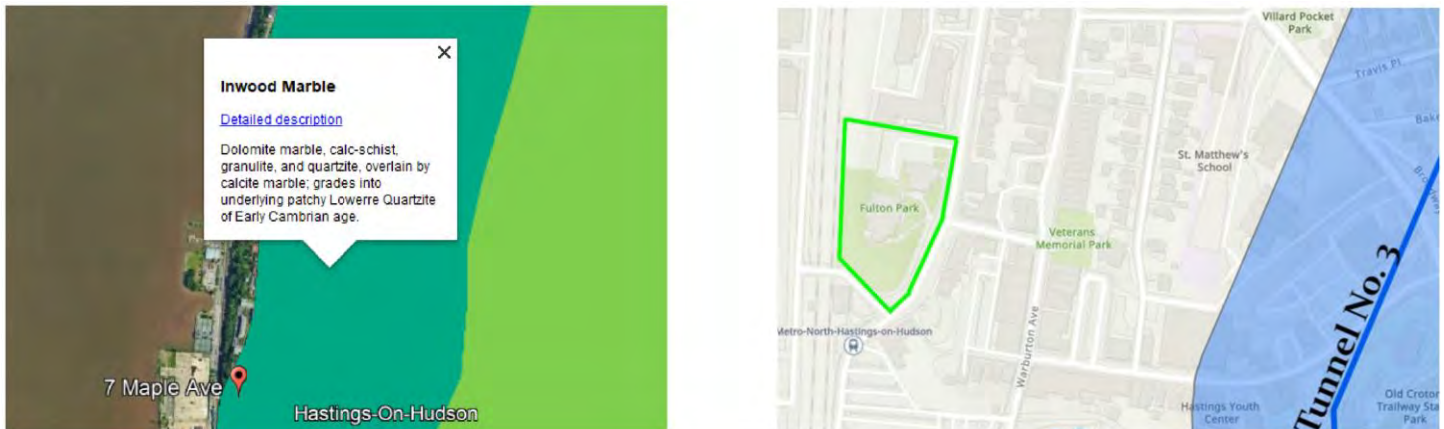

Figure 16. Site and geologic assessment of the geothermal wellfield



**BUILDING MODIFICATIONS**

A summary of the modifications anticipated at the building's HVAC systems are as follows:

System	Equipment	Modification
Low Temperature Hot Water HVAC	Library Radiators	No modifications required
Standard Hot Water HVAC Equipment	Library AHU	May need to be replaced. The system has been designed for a 40°F ΔT which will allow for existing hot water piping to be reused since there will not be a change in flow rate. A stress test should be conducted to determine if existing coils will be able to satisfy the space requirements with a max hot water temperature of 140°F.
Steam HVAC Equipment	Village Hall Radiators	Replaced with WSHP units. New neutral temperature piping to connect WSHP units.
Direct Expansion (DX) HVAC Equipment	Village Hall PTACs	Replaced with WSHP units. New neutral temperature piping to connect WSHP units.
Direct Expansion (DX) HVAC Equipment	Village Hall/Library Split DX Units	No modifications.
Chilled Water HVAC Equipment	Library AHU	No modifications

**THERMAL LOADS**

The following load profiles shows a visual representation of the potential for a geothermal based heat pump system sized to fully service the loads of the building.

Heat Recovery and Geothermal | Heating Potential

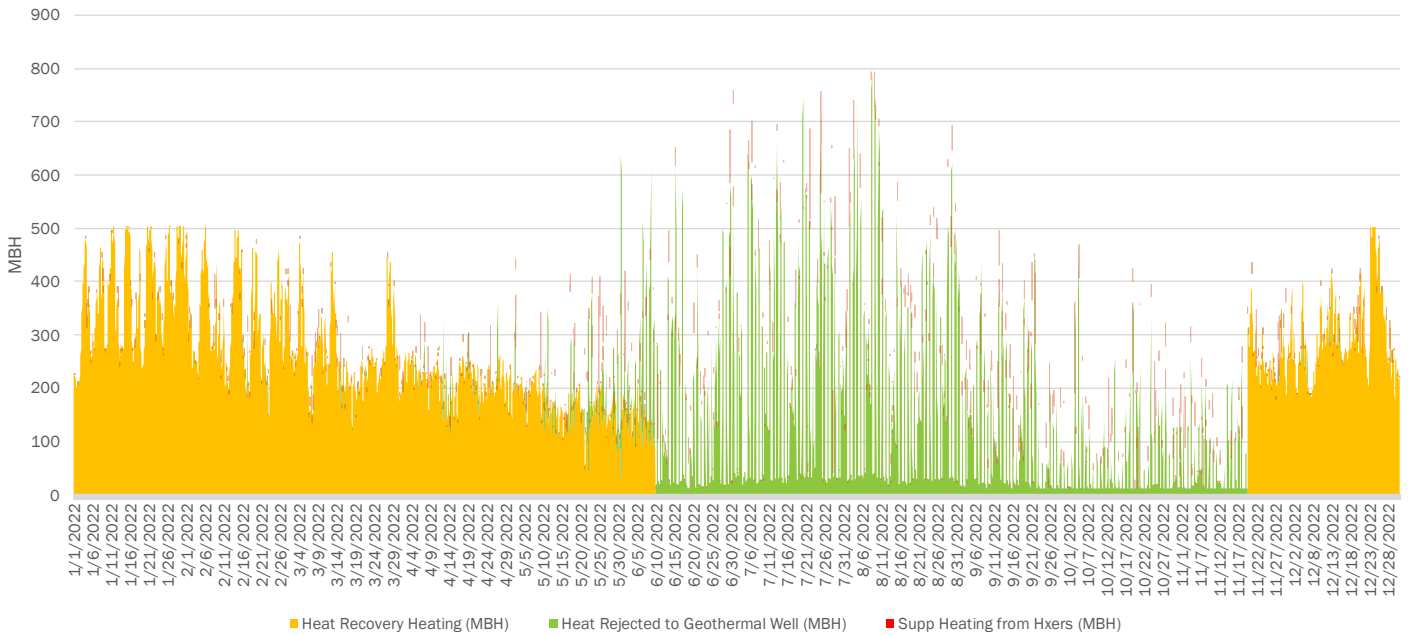

Heat Recovery and Geothermal | Cooling Potential

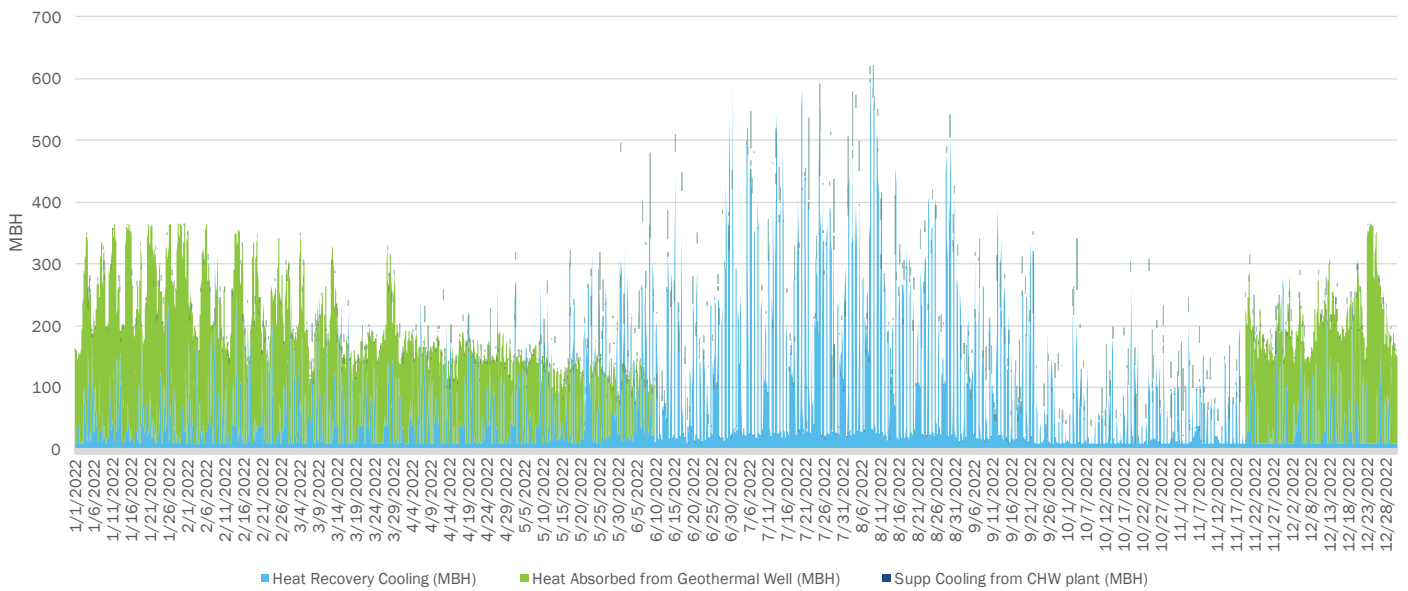

**ELECTRICAL**

A high-level review of the building’s electrical systems was conducted, which included an analysis of existing services, current peak loads, and anticipated equipment additions and removals. Presuming that the Village Hall proceeds with the 400A electrical service increase as part of the EV charging project, the additional electrical capacity resulting from that installation would provide capacity for the Geothermal Heat Pump System at Village Hall. The Library would not require any additional capacity. The design stage of the project should include a detailed review of electrical systems to confirm capacity and potential routing/breaker space. A summary of the electrical impacts can be seen below.

### Electrical Service Summary

BUILDING: Village Hall  
SERVICE VOLTAGE: 208 V

Equipment	Rated Current	Rating Type	Equipment Voltage	QTY	ADDED CURRENT (AMPS) @ 208V	
NEW 0.5 Ton WSHP Units	5	MCA	208	43	232	
NEW 1.5 Ton WSHP Units	12	MCA	208	5	62	
NEW Geo Water Loop Pumps (2)	31	FLA	208	2	62	
Remove Window ACs	6	FLA	120	-11	-37	
Remove PTAC	10	FLA	120	-1	-6	
Remove PTAC	8	FLA	120	-1	-5	
Remove Split AC	14	FLA	120	-3	-25	
Remove Library HW Pumps	3	FLA	208	-2	-5	
Added Capacity from EV Upgrade (400 Amps)	400	FLA	208	-1	-400	
EV Chargers	250	FLA	208	1	250	
<b>Current Electrical Capacity</b>					Total Added Amps 208V	128

Available  
236  
59%

Load  
164  
41%

Electrical Service   Ampacity Summary   Project Impact		
Total Capacity	Current Load	Cummulative Ampacity @ Building Voltage
400	164	293
Good		

### Electrical Service Summary

BUILDING: Library  
SERVICE VOLTAGE: 208 V

Equipment	Rated Current	Rating Type	Equipment Voltage	QTY	ADDED CURRENT (AMPS) @ 208V	
Remove Air Cooled Chiller	184	MCA	208	-1	-184	
10 Ton Heat Pump	54	MCA	208	4	216	
NEW Library Hot Water Loop Pumps (2)	3	FLA	208	2	6	
Remove Old Library CHW Loop Pumps	3	FLA	208	-2	-6	
NEW Library Chilled Water Loop Pumps (2)	2	FLA	208	2	3	
<b>Current Electrical Capacity</b>					Total Added Amps 208V	35

Available  
351  
59%

Load  
249  
41%

Electrical Service   Ampacity Summary   Project Impact		
Total Capacity	Current Load	Cummulative Ampacity @ Building Voltage
600	249	284
Good		



## PRELIMINARY SCOPE OF WORK

The following changes will be necessary as part of the Geothermal Heat Pump System.

### CENTRAL HEAT PUMP SYSTEM

**HEAT PUMP TYPE:** Modular 10ton units

**NUMBER OF HEAT PUMPS:** 4 Modules

**HEAT PUMP OPERATING TEMPERATURES:** CHW:45/55; HW:140/120; Ground loop: 55/75

**PUMPS:** 1 new pump skid

**HEAT EXCHANGER:** 60-ton water to glycol HX for ground loop

### TERMINAL HEAT PUMPS

**HEAT PUMP TYPE:** Terminal WSHPs

**NUMBER OF HEAT PUMPS:** (43) 0.75 Ton Units, & (5) 1.50 Ton Units

### DEMOLITION

- Village Hall | Remove existing boiler, condensate return and feedwater equipment. Remove associated steam distribution piping to the headers. Remove PTACs serving office areas and server rooms. Police Station heat pump systems to remain.
- Library | Remove the 1993 York Chiller and replace with Central Heat Pump system. Reuse electrical and chilled water connections.

### HEATING SYSTEM

- Library | Hot Water Piping | provide new hot water pumps, piping and accessories from Central Heat Pump to service HW coils in the AHU.
- Village Hall | Radiators | replace Radiators with Terminal Heat Pumps equipped with DDC control.

### GEOHERMAL WELLFIELD

- Wellfield | provide 20 closed-loop wells to a depth of 500' max. Provide drilling, material handling and disposal, coordination with underground utilities, vaults, valving, piping and controls.

### NEUTRAL TEMPERATURE SYSTEM

- Heat Exchanger | Provide plate and frame heat exchanger to service neutral temperature loop. Working fluid of neutral temperature loop to be propylene glycol water.
- Neutral Temperature Piping | provide new neutral temperature piping, pumps and accessories from the Central Heat Pump to the Village Hall Terminal Heat Pumps and Geothermal Wellfield.

### ELECTRICAL SYSTEM

- Electrical | provide new electrical connections from the MCC services the New Central Heat Pumps and Terminal Heat Pumps.
- Verify building electrical capacity during design phase.

**OPINION OF PROBABLE COSTS**

	Rule of Thumb		# of Units	Total
<b>Geothermal Wellfield</b>	\$15,000	/well	<b>20</b>	<b>\$300,000</b>
<b>Heat Pump Plants</b>	\$3,500	/Ton	<b>40</b>	<b>\$140,000</b>
<b>Dist. Piping</b>	\$1,000	/LF	<b>159</b>	<b>\$159,000</b>
<b>Int. Piping</b>	\$400	/LF	<b>530</b>	<b>\$212,000</b>
<b>WSHPs</b>	\$4,100	/Unit	<b>48</b>	<b>\$196,800</b>
<b>GLC / HW HX</b>	\$100,000	/Unit	<b>1</b>	<b>\$100,000</b>
<b>Parking Lot Paving</b>	\$42,093	/Unit	<b>1</b>	<b>\$42,093</b>
<b>M&amp;L Subtotal:</b>				<b>\$1,149,893</b>
<b>General Conditions (10%):</b>				<b>\$114,989</b>
<b>Contingency (10%):</b>				<b>\$126,488</b>
<b>Engineering Procurement Construction (25%):</b>				<b>\$347,843</b>
<b>Total:</b>				<b>\$1,739,213</b>

**AVOIDED CAPITAL COST**

	Rule of Thumb		# of Units	Total
<b>Chillers</b>	\$1,500	/Ton	<b>40</b>	<b>\$60,000</b>
<b>STM / HW HX</b>	\$100,000	/Unit	<b>1</b>	<b>\$100,000</b>
<b>VH HVAC Reno</b>	\$20	/sqft	<b>10,500</b>	<b>\$210,000</b>
<b>Replace Steam Boiler</b>	\$100	/MBH	<b>2,452</b>	<b>\$245,200</b>
<b>Parking Lot Paving</b>	\$42,093	/Unit	<b>1</b>	<b>\$42,093</b>
<b>M&amp;L Subtotal:</b>				<b>\$657,293</b>
<b>General Conditions (10%):</b>				<b>\$65,729</b>
<b>Contingency (10%):</b>				<b>\$72,302</b>
<b>Engineering Procurement Construction (25%):</b>				<b>\$198,831</b>
<b>Total:</b>				<b>\$994,156</b>

**NOTES:**

- Replacement of the York Chiller and Steam Boiler that are at the end of their useful lives, and a renovation of the Village Hall’s HVAC systems.
- Estimated cost of parking lot paving provided by Village.

**AIR SOURCE HEAT PUMP SYSTEM**

	Library	Village Hall
HEAT PUMP TYPE	Modular 30-ton units	Terminal WSHPs
NUMBER OF HEAT PUMPS	2 Modules	(22) 1.50 Ton
HEAT PUMP OPERATING TEMPERATURES	CHW:45/55; HW:140/120	
ELECTRIC SAVINGS	-140,149 kWh	
NATURAL GAS SAVINGS	1,536 mmBTU	
TOTAL EMISSIONS SAVINGS	44 MT CO2	

The proposed system will feature a Central Air Source Heat Pump sized to match the cooling load for the Library, and terminal Air Source Heat Pump (ASHPs) sized to match existing heating loads at the Village Hall’s individual rooms. The central heat pump will be located on the rooftop of the Library in place of the existing 40 Ton air-cooled chiller, and the terminal units will be in place of the existing radiators at the Village Hall. The central heat pump will distribute hot water and chilled water to the Library’s AHU and radiators, and the Village Hall’s ASHPs will be independent from each other. A high-level schematic of this system can be seen in Appendix 4.

**CHILLED AND HOT WATER SYSTEMS**

The Library’s chilled water distribution system will be connected to the Central Heat Pump at the existing connection point, and the hot water distribution system will be connected to the Central Heat Pump via new pumps and roughly 50’ of piping. The Hot Water pumps are sized for:

- 3. **Maximum Flow Rate:** Library HW system
- 4. **Pressure Drop:** Assumed maximum hot water distribution system ΔP.

**TERMINAL SYSTEMS**

The Village Hall’s radiators and PTACs will be replaced with individual through-the-wall ASHP units. The units will have the capability to provide outdoor air, individual unit and/or central DDC controls.

**BUILDING MODIFICATIONS**

A summary of the modifications anticipated at the building’s HVAC systems are as follows:

System	Equipment	Modification
Low Temperature Hot Water HVAC	Library Radiators	No modifications required
Standard Hot Water HVAC Equipment	Library AHU	May need to be replaced. The system has been designed for a 40 °F ΔT which will allow for existing hot water piping to be reused since there will not be a change in flow rate. A stress test should be conducted to determine if existing coils will be able to satisfy the space requirements with a max hot water temperature of 140 °F.
Steam HVAC Equipment	Village Hall Radiators	Replaced with ASHP units
Direct Expansion (DX) HVAC Equipment	Village Hall PTACs	Replaced with ASHP units
Direct Expansion (DX) HVAC Equipment	Village Hall/Library Split DX Units	No modifications.
Chilled Water HVAC Equipment	Library AHU	No modifications



Figure 16. Sample proposed Central Heat Pump to replace Library chiller



**THERMAL LOADS**

The following load profiles shows a visual representation of the potential for heat recovery based on simultaneous heating and cooling loads at the Library.

Air Source and Hybrid | Heating Potential | Library

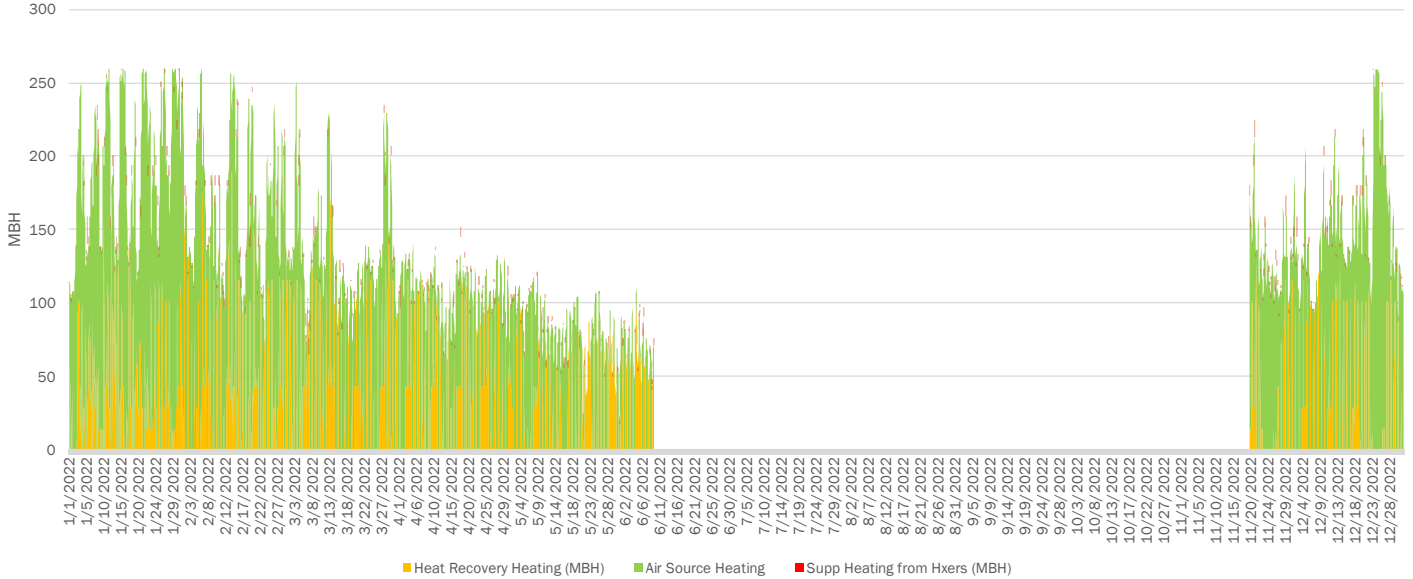

Air Source and Hybrid | Cooling Potential | Library

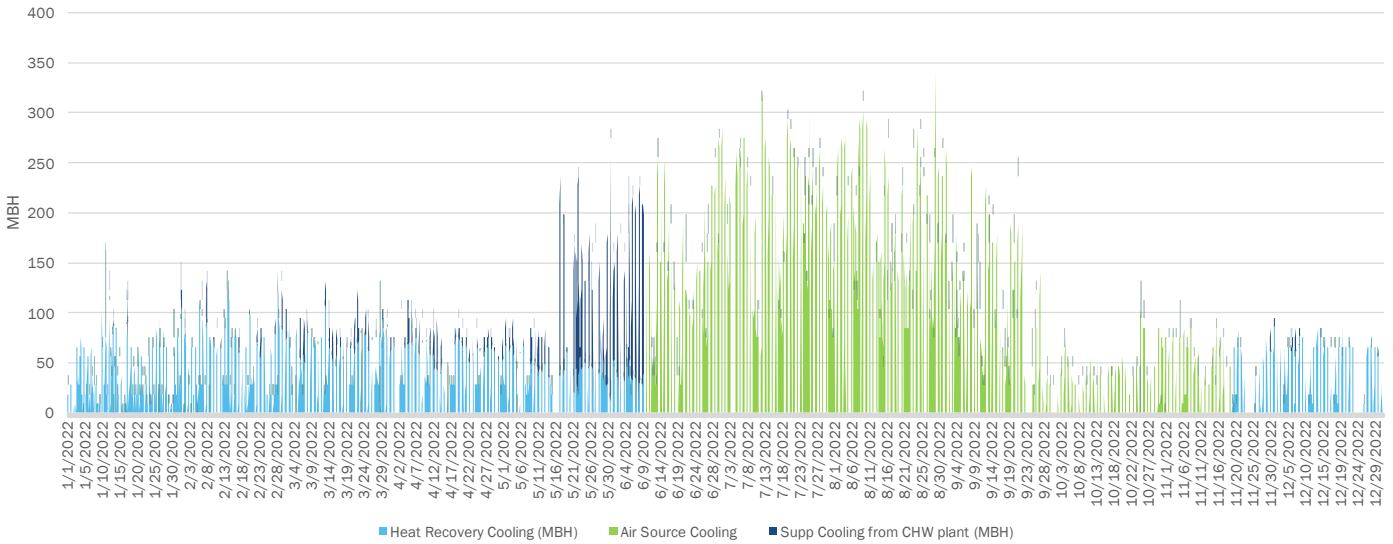

The following load profiles shows a visual representation of the heating and cooling loads at the Village Hall. Unlike the other graphs and scenarios presented, this option does not have the option for heat recovery since the terminal units are comprised of ASHPs that are not thermally connected to each other.

Air Source and Hybrid | Heating Potential | Village Hall

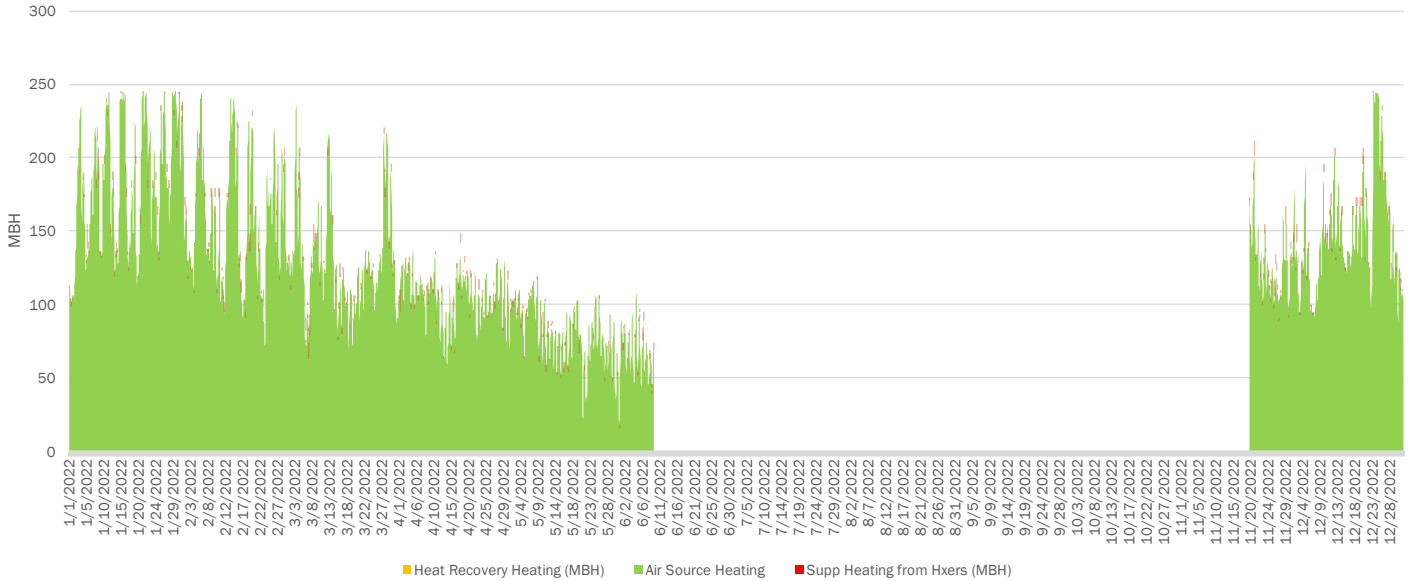

Air Source and Hybrid | Cooling Potential | Village Hall

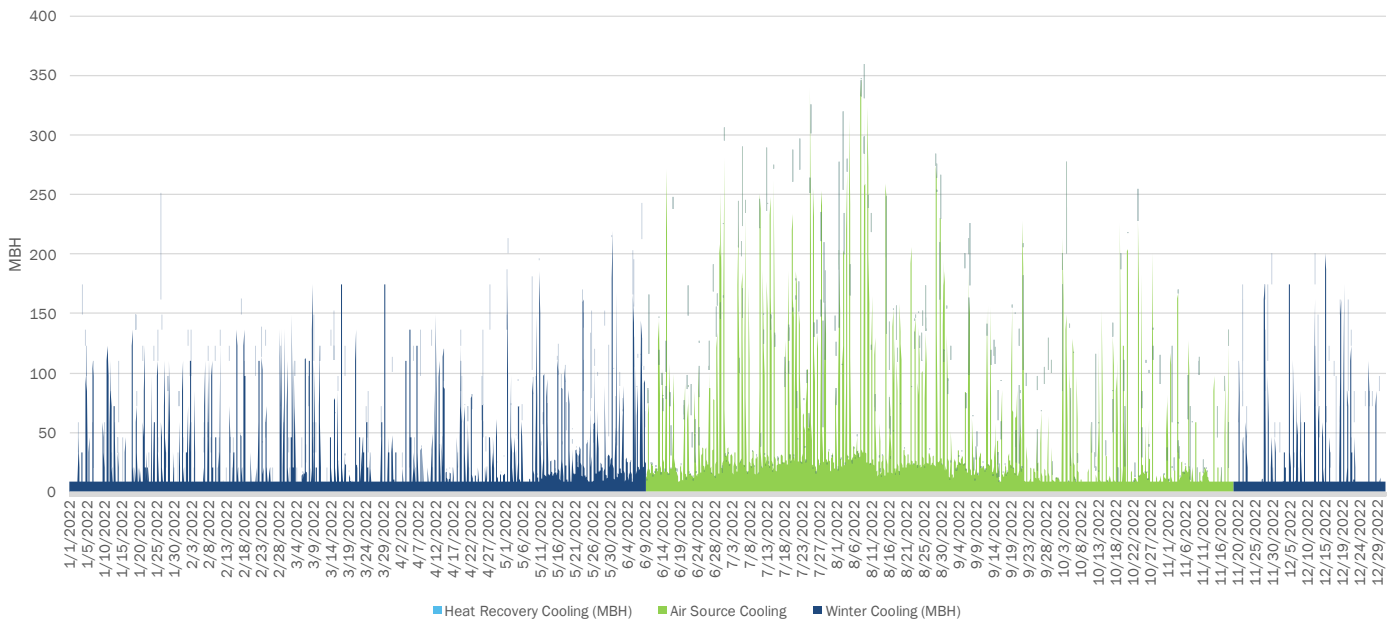

**ELECTRICAL**

A high-level review of the building’s electrical systems was conducted, which included an analysis of existing services, current peak loads, and anticipated equipment additions and removals. Presuming that the Village Hall proceeds with the 400A electrical service increase as part of the EV charging project, the additional electrical capacity resulting from that installation would provide capacity for the Geothermal Heat Pump System at Village Hall. The Library would not require any additional capacity. The design stage of the project should include a detailed review of electrical systems to confirm capacity and potential routing/breaker space. A summary of the electrical impacts can be seen below.

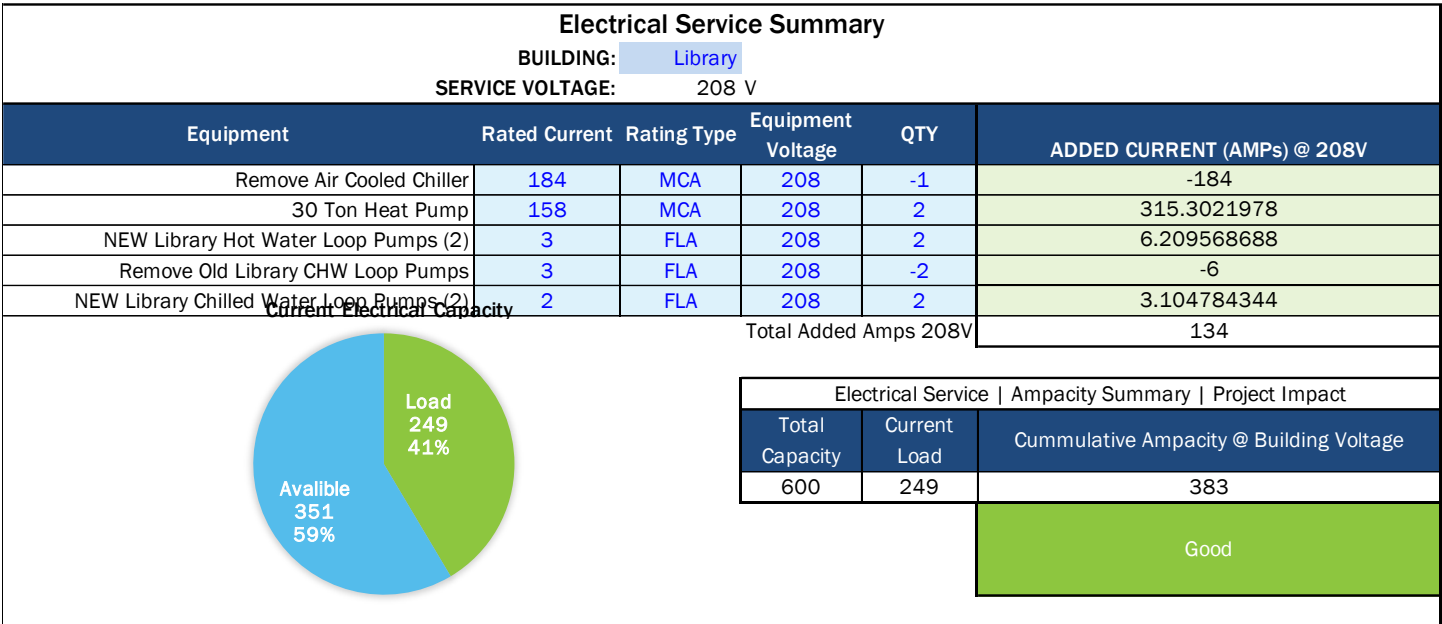
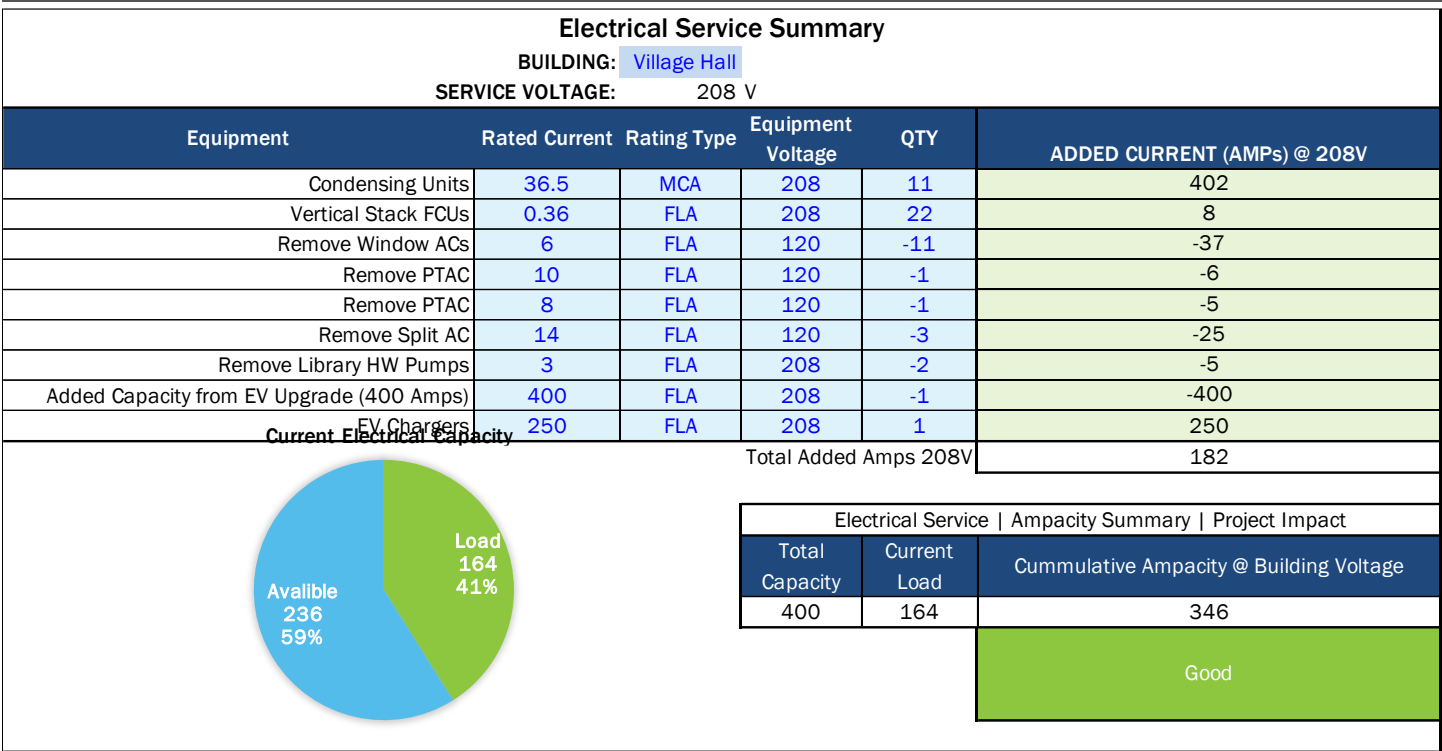



---

## LIKELY SCOPE OF WORK

The following changes will be necessary as part of the Air Source Heat Pump System.

### **CENTRAL HEAT PUMP SYSTEM**

**HEAT PUMP TYPE:** Modular 20 ton units

**NUMBER OF HEAT PUMPS:** 2 Modules

**HEAT PUMP OPERATING TEMPERATURES:** 45/55degF and 140/120degF

**PUMPS:** 2 new pump skids

### **TERMINAL HEAT PUMPS**

**HEAT PUMP TYPE:** Terminal ASHPs

**NUMBER OF HEAT PUMPS:** (22) 1.50 Ton Units

### **DEMOLITION**

- Village Hall | Remove existing boiler, condensate return and feedwater equipment. Remove associated steam distribution piping to the headers. Remove PTACs serving office areas and server rooms. Police Station heat pump systems to remain.
- Library | Remove the 1993 York Chiller and replace with Central Heat Pump system. Reuse electrical and chilled water connections.

### **HEATING SYSTEM**

- Library | Hot Water Piping | provide new hot water pumps, piping and accessories from Central Heat Pump to service HW coils in the AHU.
- Village Hall | Radiators | remove Radiators and replace with Terminal Heat Pumps equipped with DDC control.

### **ELECTRICAL SYSTEM**

- Electrical | provide new electrical connections from the MCC services the New Central Heat Pumps and Terminal Heat Pumps.
- Verify building electrical capacity during design phase.

**OPINION OF PROBABLE COSTS**

	Rule of Thumb		# of Units	Total
<b>Geothermal Wellfield</b>	\$15,000	/well	<b>0</b>	<b>\$0</b>
<b>Heat Pump Plants</b>	\$5,000	/Ton	<b>60</b>	<b>\$300,000</b>
<b>Dist. Piping</b>	\$1,000	/LF	<b>50</b>	<b>\$50,000</b>
<b>Int. Piping</b>	\$400	/LF	<b>0</b>	<b>\$0</b>
<b>ASHPs</b>	\$11,500	/Unit	<b>22</b>	<b>\$253,000</b>
<b>M&amp;L Subtotal:</b>				<b>\$603,000</b>
<b>General Conditions (10%):</b>				<b>\$60,300</b>
<b>Construction Contingency (10%):</b>				<b>\$66,330</b>
<b>Engineering Procurement Construction (25%):</b>				<b>\$182,408</b>
<b>Total:</b>				<b>\$912,038</b>

**AVOIDED CAPITAL COST**

	Rule of Thumb		# of Units	Total
<b>Chillers</b>	\$1,500	/Ton	<b>40</b>	<b>\$60,000</b>
<b>STM / HW HX</b>	\$100,000	/Unit	<b>1</b>	<b>\$100,000</b>
<b>VH HVAC Reno</b>	\$20	/sqft	<b>10,500</b>	<b>\$210,000</b>
<b>Replace Steam Boiler</b>	\$100	/MBH	<b>2452</b>	<b>\$245,200</b>
<b>M&amp;L Subtotal:</b>				<b>\$615,200</b>
<b>General Conditions (10%):</b>				<b>\$61,520</b>
<b>Contingency (10%):</b>				<b>\$67,672</b>
<b>Engineering Procurement Construction (25%):</b>				<b>\$186,098</b>
<b>Total:</b>				<b>\$930,490</b>

NOTES:

- Replacement of the York Chiller and Steam Boiler that are at the end of their useful lives, and a renovation of the Village Hall’s HVAC systems. Costs of parking lot paving are not included as part of avoided costs since parking lot would be out of ASHP project scope.



# section f

---

implementation plan



## IMPLEMENTATION PLAN

### RECOMMENDED SCOPE OF WORK

The following changes will be necessary as part of the recommended project, which includes the Geothermal Heat Pump System and Library Rooftop PV measures.

#### CENTRAL HEAT PUMP SYSTEM

**HEAT PUMP TYPE:** Modular 10ton units

**NUMBER OF HEAT PUMPS:** 4 Modules

**HEAT PUMP OPERATING TEMPERATURES:** CHW:45/55; HW:140/120; Ground loop: 55/75

**PUMPS:** 1 new pump skid

**HEAT EXCHANGER:** 60 ton water to glycol HX for ground loop

#### TERMINAL HEAT PUMPS

**HEAT PUMP TYPE:** Terminal WSHPs

**NUMBER OF HEAT PUMPS:** (43) 0.75 Ton Units, & (5) 1.50 Ton Units

#### SOLAR PV SYSTEM

**SYSTEM TYPE:** Roof Mount Solar PV Array

**SYSTEM SIZE:** 125 kW Array, (2) 65kW Inverters

#### DEMOLITION

- Village Hall | Remove existing boiler, condensate return and feedwater equipment. Remove associated steam distribution piping to the headers. Remove PTACs serving office areas and server rooms. Police Station heat pump systems to remain.
- Library | Remove the 1993 York Chiller and replace with Central Heat Pump system. Reuse electrical and chilled water connections.

#### HEATING SYSTEM

- Library | Hot Water Piping | provide new hot water pumps, piping and accessories from Central Heat Pump to service HW coils in the AHU.
- Village Hall | Radiators | replace Radiators with Terminal Heat Pumps equipped with DDC control.

#### GEOTHERMAL WELLFIELD

- Wellfield | provide 20 closed-loop wells to a depth of 500' max. Provide drilling, material handling and disposal, coordination with underground utilities, vaults, valving, piping and controls.

#### NEUTRAL TEMPERATURE SYSTEM

- Heat Exchanger | Provide plate and frame heat exchanger to service neutral temperature loop. Working fluid of neutral temperature loop to be propylene glycol water.
- Neutral Temperature Piping | provide new neutral temperature piping, pumps and accessories from the Central Heat Pump to the Village Hall Terminal Heat Pumps and Geothermal Wellfield.

#### ELECTRICAL SYSTEM

- Electrical | provide new electrical connections from the MCC services the New Central Heat Pumps and Terminal Heat Pumps.
- Verify building electrical capacity during design phase.
- Solar PV | provide rack mounting and PV panels. Coordinate interconnection with local utility and obtain approval prior to installation.

**OPINION OF PROBABLE COSTS**

	Rule of Thumb		# of Units	Total
Geothermal Wellfield	\$15,000	/well	20	\$300,000
Heat Pump Plants	\$3,500	/Ton	40	\$140,000
Dist. Piping	\$1,000	/LF	159	\$159,000
Int. Piping	\$400	/LF	530	\$212,000
WSHPs	\$4,100	/Unit	48	\$196,800
GLC / HW HX	\$100,000	/Unit	1	\$100,000
Parking Lot Paving	\$42,093	/Unit	1	\$42,093
Solar Array	\$2,000	/kW	125	\$249,426
<b>M&amp;L Subtotal:</b>				<b>\$1,399,319</b>
<b>General Conditions (10%):</b>				<b>\$139,932</b>
<b>Design Contingency (10%):</b>				<b>\$0</b>
<b>Contingency (10%):</b>				<b>\$153,925</b>
<b>Engineering Procurement Construction (25%):</b>				<b>\$423,294</b>
<b>Total:</b>				<b>\$2,116,470</b>

**AVOIDED CAPITAL COST**

	Rule of Thumb		# of Units	Total
Chillers	\$1,500	/Ton	40	\$60,000
STM / HW HX	\$100,000	/Unit	1	\$100,000
VH HVAC Reno	\$20	/sqft	10,500	\$210,000
Replace Steam Boiler	\$100	/MBH	2,452	\$245,200
Parking Lot Paving	\$42,093	/Unit	1	\$42,093
<b>M&amp;L Subtotal:</b>				<b>\$657,293</b>
<b>General Conditions (10%):</b>				<b>\$65,729</b>
<b>Contingency (10%):</b>				<b>\$72,302</b>
<b>Engineering Procurement Construction (25%):</b>				<b>\$198,831</b>
<b>Total:</b>				<b>\$994,156</b>

NOTES:

- Replacement of the York Chiller and Steam Boiler that are at the end of their useful lives, and a renovation of the Village Hall's HVAC systems.
- Estimated cost of parking lot paving provided by Village.



# section g

---

next steps



**INCENTIVES & REBATES**

**NY SUN INCENTIVE PROGRAM**

The NY-Sun Incentive Program is a NY State program, offering incentives through NYSERDA to organizations that invest in grid-connected solar photovoltaic systems. Funding for the program has been allocated by the New York State Public Service Commission through the Clean Energy Fund (CEF) with additional funding made available through the Regional Greenhouse Gas Initiative (RGGI). This credit provides incentives based on the capacity of the solar array (\$/W), determined based on blocks of available funding for a \$/W, as seen in the image below. The arrays proposed as part of this project fall into the non-residential size category of less than 200kW.

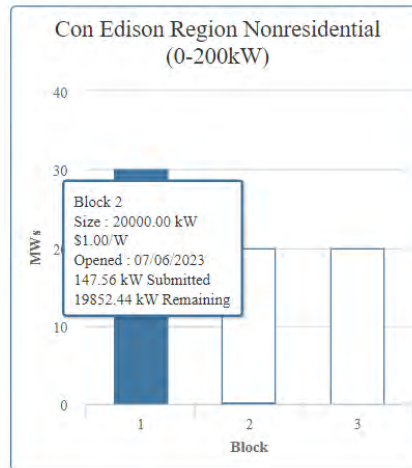

**Figure 17.** Available NY-Sun funding for the Con Edison Region as of 7/11/2023 (<https://www.nyserda.ny.gov/All-Programs/NY-Sun/Contractors/Dashboards-and-incentives/ConEd-Dashboard>)

This incentive is allocated on a first-come-first-serve basis, and, for the Con Edison Nonresidential category, Block 2 of 3 is currently being filled which has a rate of \$1.00/W of solar capacity. The length of time that this incentive remains is dependent on other projects in NYS. Block 1 was open from 6/7/22 through 7/6/23. If this project falls to Block 3, this would be an incentive of \$0.80/W. The anticipated NY Sun incentive for the proposed Solar PV arrays presuming availability of Block 2 funding can be seen below:

Measure	Size of PV Array (W)	Anticipated NY Sun \$/W	Estimated NY Sun Benefit (\$)
Village Hall Parking Lot Parking Canopy PV	51,824	\$1.00/W	\$51,824
Library Rooftop Solar PV	124,713	\$1.00/W	\$124,713

**INFLATION REDUCTION ACT | SECTION 48 ALTERNATIVE ENERGY INVESTMENT TAX CREDIT**

As part of the Inflation Reduction Act of 2022 (IRA), the Section 48 Alternative Energy Investment Tax Credit (ITC) was expanded in scope. One of the major additions was the eligibility of State governments and their political subdivisions to monetize these tax credits in the form of a “direct pay” (Sec. 6417). This allows the Village to avail themselves to these tax credits, which can range from 6%-70% of an eligible project’s costs, net of any utility rebates.

Technology	Base Credit	5x Bonus Credit	Domestic Content	Energy Community	Low Income	Range
Solar PV	6%	30%	2% or 10%	2% or 10%	10% or 20%	<b>6%-70%</b>
Ground Source Heat Pump	6%	30%	2% or 10%	2% or 10%	0%	<b>6%-50%</b>

Since each system is anticipated to fall below 1 MW capacity, the Solar PV and Ground Source Heat Pump Installations likely allow for the 5X Bonus credit of 30% regardless of whether implementation meets the ITC’s prevailing wage and apprenticeship requirements. The additional 10% for meeting Domestic Content provisions is potentially attainable for the Ground Source Heat Pump project since often these materials are US-made. Because this additional provision is dependent on specific choices made both during construction and when filing for the ITC, we are providing two Scenarios for the ITC calculation – one with this additional 10% for Geothermal and one without. The location of the site is not in an area defined as eligible for the Energy Community or Low-Income bonuses in 2022 by the DOE or IRS. The anticipated low/high ITC for each proposed measure is estimated below:

Measure	Estimated % of Project Cost Eligible	Estimated ITC Low (\$)	Estimated ITC High (\$)
Geothermal Water-to-Water Heat Pump	30% (Low) – 40% (High)	\$521,764	\$695,685
Air-to-Water Heat Pump	0%	\$0	\$0
Village Hall Parking Lot Parking Canopy PV	30%	\$46,641	\$46,641
Library Rooftop Solar PV	30%	\$37,414	\$37,414

**FINANCING AND OWNERSHIP MODELS**

Many options for ownership are available to municipalities to implement renewable energy projects. A summary is included below:

**LEASING**

Leasing is a popular financing option for renewable energy systems, allowing organizations to access and benefit from clean energy technologies without the upfront costs of equipment ownership. Through lease agreements, lessees pay regular installments or rental fees to the lessor, who owns and maintains the renewable energy system. Leasing may provide the same reduced energy costs and emissions reductions as direct ownership, but without the burden of upfront capital investment and equipment maintenance. In a lease arrangement, incentives would typically go to the economic owner of the property.

**POWER PURCHASE AGREEMENTS (PPA)**

PPAs are similar to leasing arrangements, except that instead of paying to “rent” the energy equipment, the end user is paying to access the energy itself. Under a PPA, an agreement would be developed between the electricity generator and the buyer, with terms of electricity purchase for a certain period. Under a PPA, the owner of the equipment would typically be responsible for upfront investments and equipment maintenance. PPAs have traditionally been a big driver of renewable energy implementation since they can provide stability and revenue certainty for renewable energy projects, and lower upfront costs for end-users. Similar to a lease, with a PPA, incentives would typically go to the economic owner of the property.

**DIRECT OWNESHIP**

Direct ownership is the scenario where the purchase and ownership of energy equipment is by the end user. Direct ownership allows for direct monetization of available incentives, rebates and grants, as well as full control over its operation and maintenance. Direct Ownership can provide the lowest life-cycle costs of ownership, especially now that local governments are able to monetize the expanded ITC and other incentives, but it also comes with the upfront investment. Furthermore in addition to the long-term energy cost savings, direct ownership may enable an end user to benefit from additional potential revenue in the form of excess energy production through net metering or feed-in tariffs.

**COMMUNITY OWNERSHIP**

Community ownership of energy projects involves local individuals, organizations, or communities coming together to collectively own and benefit from energy initiatives. Community-owned projects can increase resilience and reduce emissions for a community and, when compared to other ownership models, the energy cost savings can stay within the community. They also have the benefit of facilitating educational opportunities and raising local awareness of renewable energy.

## NEXT STEPS

Should the Village choose to advance this study forward the following are the recommended next steps:

- Test well to confirm wellfield conductivity
  - Well field conductivity is assumed to be 2.5 tons per 500LF well in this study. A test well to confirm will possibly impact depth/sizing/number of wells
- Design Phase
  - Ensure inclusion of a detailed energy model to determine building thermal loads
- Construction Phase

## DESIGN CONSIDERATIONS

The following design consideration are recommended to be investigated during the design phase:

- Physical Space
- Electrical capacity/distribution
- Controls infrastructure
- Hot water & chilled water connection points
- Wellfield layout
- Contaminated soils
- Solar Interconnection Capacity
- Redundant Wellfield Heat Exchangers
- Alternative Buried Piping Materials
- Excavation Unknowns
- Redundancy/Resiliency Strategies

## PROJECT DELIVERY METHODS AND TIMELINE

This project includes equipment with potential for long lead times, such as heat pumps, Variable Frequency Drives, switchgears/breakers, etc, which can delay the completion dates. A high-level implementation timeline for the recommended project utilizing typical delivery methods (60% design, 90% design, bidding, construction) can be seen below.

### Project Plan | Village of Hastings-on-Hudson | Typical

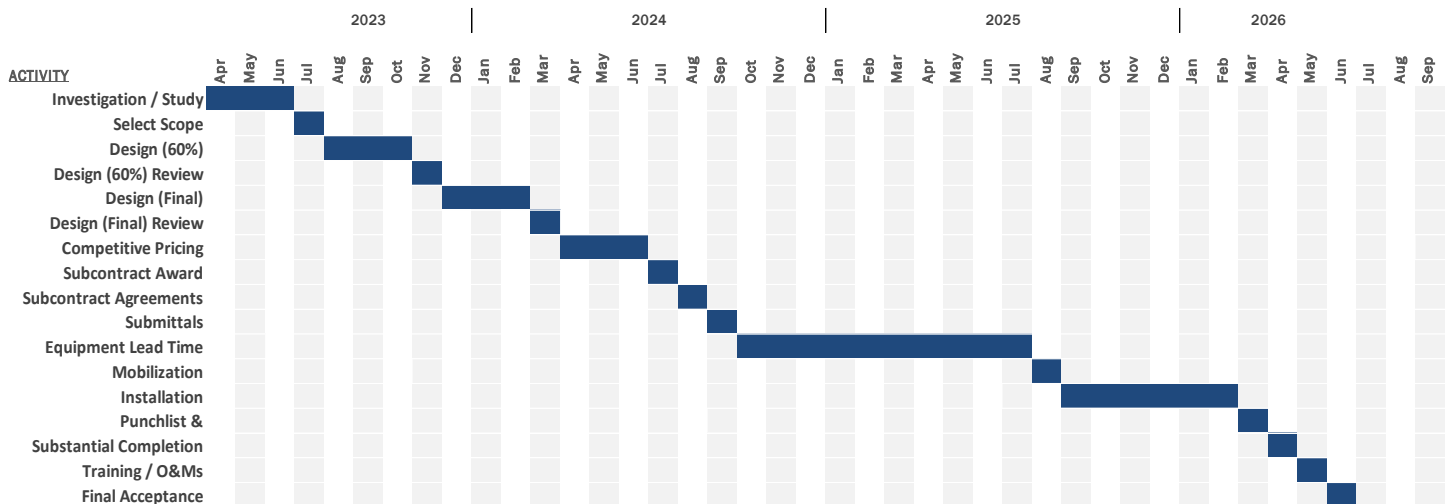

Using alternative delivery models, such as Design-Build, steps can be taken to accelerate implementation timelines, such as preordering equipment with long lead times. Enrolling in purchasing programs, such as The Interlocal Purchasing System (TIPS), may allow municipalities to avail themselves to these alternative delivery models. The following timeline shows the potential implementation for the recommended project using an accelerated timeline.



## Project Plan | Village of Hastings-on-Hudson | Accelerated Timeline

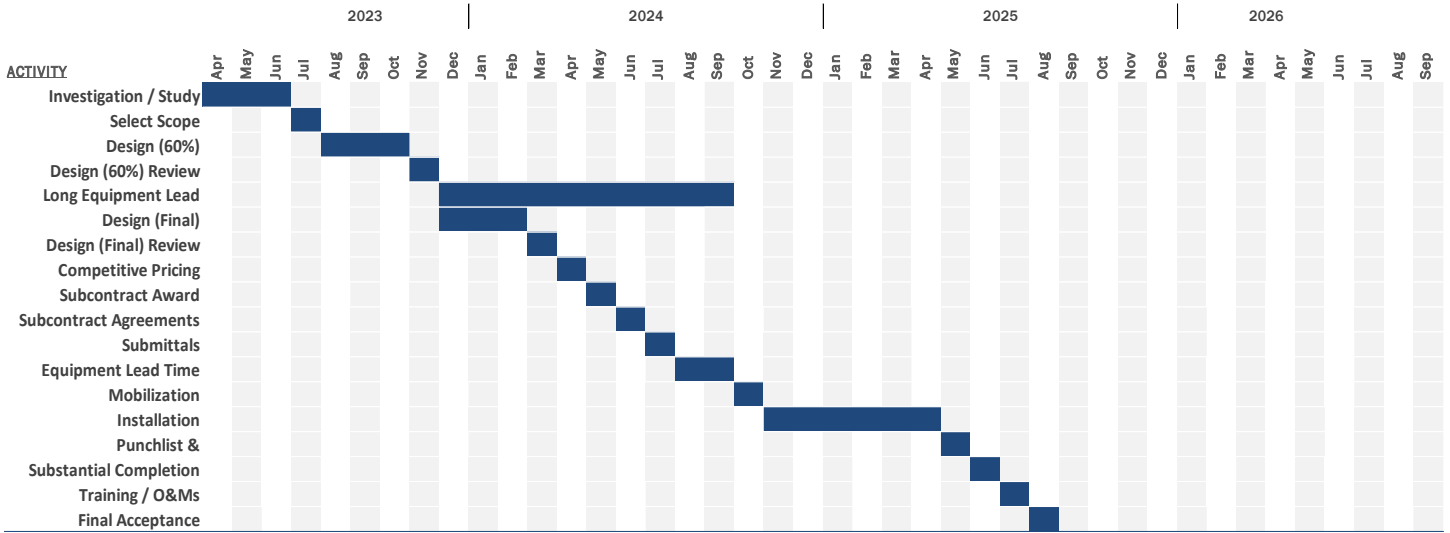



# appendix 1

---

utilities

Building Name: Village Hall  
 Address: 7 Maple Ave  
 Hastings on Hudson, NY 10706  
 Facility Area: 10,595 sq.ft.



Date: 7/11/2023  
 Utility Company: NYPA  
 Acct. No.: 590906066435003  
 Meter: 9988992  
 Rate: GOV\_WES\_69

ANNUAL ELECTRIC UTILITY DATA

Billing Year	Billing Month	Customer Charge	Demand Total (kW)	Demand Cost	Usage Total (kWh)	Usage Supply Cost	Usage Delivery Cost	Total Cost	Billing Days	Load Factor
2019	Jan		25.2		11,640	\$649.52	\$738.81	\$1,388.33	31	0.62
2019	Feb		23.2		15,080	\$763.67	\$640.68	\$1,404.35	28	0.97
2019	Mar		22.4		7,320	\$467.66	\$659.80	\$1,127.46	31	0.44
2019	Apr		22.8		10,280	\$408.99	\$608.67	\$1,017.66	30	0.63
2019	May		22.0		8,880	\$430.82	\$590.09	\$1,020.91	31	0.54
2019	Jun		24.8		10,680	\$548.02	\$787.80	\$1,335.82	30	0.60
2019	Jul		32.4		10,880	\$582.30	\$952.95	\$1,535.25	31	0.45
2019	Aug		36.8		11,800	\$546.05	\$1,013.91	\$1,559.96	30	0.45
2019	Sep		31.2		11,720	\$651.34	\$955.50	\$1,606.84	31	0.50
2019	Oct		28.4		9,680	\$467.31	\$795.41	\$1,262.72	31	0.46
2019	Nov		24.4		9,520	\$363.46	\$688.71	\$1,052.17	30	0.54
2019	Dec		24.4		11,440	\$501.34	\$800.37	\$1,301.71	31	0.63
2020	Jan		24.0		10,000	\$319.37	\$699.45	\$1,018.82	31	0.56
2020	Feb		24.4		10,640	\$281.75	\$796.91	\$1,078.66	28	0.65
2020	Mar		24.4		9,760	\$292.42	\$757.88	\$1,050.30	31	0.54
2020	Apr		22.0		8,600	\$238.48	\$666.52	\$905.00	30	0.54
2020	May		17.6		8,160	\$198.93	\$551.42	\$750.35	31	0.62
2020	Jun		20.8		8,920	\$276.33	\$695.97	\$972.30	30	0.60
2020	Jul		30.4		9,960	\$434.89	\$933.85	\$1,368.74	31	0.44
2020	Aug		32.4		11,040	\$441.62	\$961.34	\$1,402.96	30	0.47
2020	Sep		36.8		11,240	\$515.27	\$1,183.00	\$1,698.27	31	0.41
2020	Oct		30.0		9,040	\$339.07	\$903.12	\$1,242.19	31	0.41
2020	Nov		24.4		8,800	\$300.98	\$756.82	\$1,057.80	30	0.50
2020	Dec		23.6		10,840	\$435.55	\$858.08	\$1,293.63	31	0.62
2021	Jan		27.2		11,120	\$369.76	\$961.96	\$1,331.72	31	0.55
2021	Feb		28.8		10,560	\$435.09	\$943.49	\$1,378.58	28	0.55
2021	Mar		29.2		10,120	\$495.06	\$959.51	\$1,454.57	31	0.47
2021	Apr		25.6		10,520	\$769.42	\$878.07	\$1,647.49	30	0.57
2021	May		29.6		9,560	\$424.45	\$925.12	\$1,349.57	31	0.43
2021	Jun		44.4		10,760	\$499.43	\$1,422.06	\$1,921.49	30	0.34
2021	Jul		42.0		11,680	\$707.26	\$1,350.88	\$2,058.14	31	0.37
2021	Aug		36.4		11,920	\$713.04	\$1,239.50	\$1,952.54	30	0.45
2021	Sep		33.2		11,560	\$693.16	\$1,110.60	\$1,803.76	31	0.47
2021	Oct		29.6		9,360	\$649.09	\$961.67	\$1,610.76	31	0.43
2021	Nov		26.8		8,840	\$487.64	\$896.92	\$1,384.56	30	0.46
2021	Dec		25.2		10,600	\$701.81	\$957.73	\$1,659.54	31	0.57
2022	Jan		28.0		10,480	\$828.65	\$1,011.54	\$1,840.19	31	0.50
2022	Feb		34.0		10,720	\$761.05	\$1,147.96	\$1,909.01	28	0.47
2022	Mar		27.2		10,720	\$1,701.61	\$934.00	\$2,635.61	31	0.53
2022	Apr		27.6		10,800	\$1,163.27	\$976.55	\$2,139.82	30	0.54
2022	May		30.8		10,080	\$813.71	\$1,013.61	\$1,827.32	31	0.44
2022	Jun		35.2		9,920	\$776.26	\$1,185.06	\$1,961.32	30	0.39
2022	Jul		36.0		10,840	\$911.07	\$1,294.08	\$2,205.15	31	0.40
2022	Aug		42.4		11,520	\$956.83	\$1,365.89	\$2,322.72	30	0.38
2022	Sep		37.6		10,440	\$1,336.46	\$1,242.62	\$2,579.08	31	0.37
2022	Oct		35.2		9,400	\$1,571.87	\$1,150.03	\$2,721.90	31	0.36
2022	Nov		34.4		10,160	\$1,154.77	\$1,187.67	\$2,342.44	30	0.41
2022	Dec		28.8		10,320	\$730.93	\$1,045.81	\$1,776.74	31	0.48
<b>2022 Totals</b>		<b>\$0.00</b>	<b>397.2</b>	<b>\$0.00</b>	<b>125,400</b>	<b>\$12,706.48</b>	<b>\$13,554.82</b>	<b>\$26,261.30</b>	<b>365</b>	<b>0.04</b>

Table Formulas:

Hours per Month (h) = G x 24  
 Total Cost (F) = B + D + E  
 Load Factor (H) = C / (A x h)

Summary

Energy Intensity (kWh/sq.ft.):	11.84
Cost Intensity (\$/sq.ft.):	\$2.48
Blended Cost (inc.demand) / kWh:	\$0.209
<b>Avg. Cost / kW:</b>	<b>\$0.00</b>
<b>Avg. Cost / kWh:</b>	<b>\$0.2094</b>

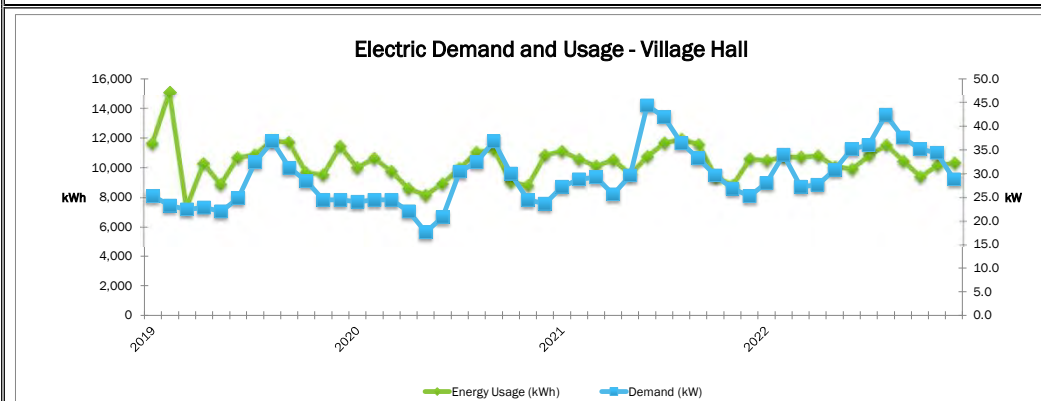



Building Name: **Library**  
 Address: **7 Maple Ave**  
 Hastings on Hudson, NY 10706  
 Facility Area: **13,225** sq.ft.



Date: **7/11/2023**  
 Utility Company: **NYPA**  
 Acct. No.: **590906066445002**  
 Meter: **9425112**  
 Rate: **GOV\_WES\_69**

**ANNUAL ELECTRIC UTILITY DATA**

Billing Year	Billing Month	Customer Charge	Demand Total (kW)	Demand Cost	Usage Total (kWh)	Usage Supply Cost	Usage Delivery Cost	Total Cost	Billing Days	Load Factor
2019	Jan		28.0		9,120	\$527.83	\$848.21	\$1,376.04	31	0.44
2019	Feb		24.8		9,920	\$524.84	\$685.11	\$1,209.95	28	0.60
2019	Mar		26.4		8,720	\$533.66	\$777.80	\$1,311.46	31	0.44
2019	Apr		28.8		9,040	\$376.44	\$768.96	\$1,145.40	30	0.44
2019	May		26.4		8,160	\$406.65	\$708.89	\$1,115.54	31	0.42
2019	Jun		46.4		8,960	\$478.60	\$1,448.49	\$1,927.09	30	0.27
2019	Jul		43.2		11,280	\$611.82	\$1,274.43	\$1,886.25	31	0.35
2019	Aug		60.0		14,240	\$671.59	\$1,647.46	\$2,319.05	30	0.33
2019	Sep		57.6		14,800	\$837.27	\$1,748.29	\$2,585.56	31	0.35
2019	Oct		48.0		9,440	\$472.17	\$1,333.74	\$1,805.91	31	0.26
2019	Nov		67.2		9,120	\$379.60	\$1,846.42	\$2,226.02	30	0.19
2019	Dec		27.2		5,680	\$250.89	\$318.22	\$569.11	31	0.28
2020	Jan		28.0		8,880	\$299.99	\$829.09	\$1,129.08	31	0.43
2020	Feb		30.4		9,280	\$261.47	\$1,008.04	\$1,269.51	28	0.45
2020	Mar		26.4		8,160	\$262.02	\$845.55	\$1,107.57	31	0.42
2020	Apr		17.6		5,760	\$180.94	\$96.76	\$277.70	30	0.45
2020	May		14.4		5,120	\$146.97	\$103.69	\$250.66	31	0.48
2020	Jun		41.6		8,000	\$264.02	\$1,352.50	\$1,616.52	30	0.27
2020	Jul		47.2		12,320	\$545.62	\$1,439.28	\$1,984.90	31	0.35
2020	Aug		45.6		12,880	\$521.44	\$1,353.89	\$1,875.33	30	0.39
2020	Sep		47.2		13,600	\$625.59	\$1,528.59	\$2,154.18	31	0.39
2020	Oct		39.2		10,720	\$408.19	\$1,188.77	\$1,596.96	31	0.37
2020	Nov		35.2		7,920	\$285.56	\$1,083.43	\$1,368.99	30	0.31
2020	Dec		27.2		5,680	\$251.21	\$1,020.39	\$1,271.60	31	0.28
2021	Jan		13.6		5,520	\$203.29	\$138.54	\$341.83	31	0.55
2021	Feb		23.2		8,400	\$357.11	\$798.30	\$1,155.41	28	0.54
2021	Mar		20.0		8,640	\$432.18	\$102.41	\$534.59	31	0.58
2021	Apr		19.2		7,920	\$592.56	\$100.24	\$692.80	30	0.57
2021	May		21.6		6,000	\$281.69	\$714.81	\$996.50	31	0.37
2021	Jun		44.0		9,120	\$429.10	\$1,421.93	\$1,851.03	30	0.29
2021	Jul		55.2		12,400	\$760.51	\$1,757.44	\$2,517.95	31	0.30
2021	Aug		47.2		14,240	\$855.20	\$1,579.67	\$2,434.87	30	0.42
2021	Sep		48.8		12,320	\$750.84	\$1,583.18	\$2,334.02	31	0.34
2021	Oct		44.0		10,240	\$717.01	\$1,383.08	\$2,100.09	31	0.31
2021	Nov		22.4		7,680	\$434.92	\$775.11	\$1,210.03	30	0.48
2021	Dec		26.4		9,520	\$640.77	\$1,004.97	\$1,645.74	31	0.48
2022	Jan		25.6		9,360	\$751.16	\$936.15	\$1,687.31	31	0.49
2022	Feb		34.4		9,600	\$691.94	\$1,162.03	\$1,853.97	28	0.42
2022	Mar		30.4		8,640	\$1,385.27	\$1,038.63	\$2,423.90	31	0.38
2022	Apr		27.2		8,960	\$978.16	\$968.59	\$1,946.75	30	0.46
2022	May		22.4		7,600	\$628.79	\$765.28	\$1,394.07	31	0.46
2022	Jun		48.0		9,360	\$746.50	\$1,596.70	\$2,343.20	30	0.27
2022	Jul		40.8		11,520	\$971.21	\$1,464.49	\$2,435.70	31	0.38
2022	Aug		48.0		13,200	\$1,095.82	\$1,547.33	\$2,643.15	30	0.38
2022	Sep		48.8		11,840	\$1,521.53	\$1,602.70	\$3,124.23	31	0.33
2022	Oct		40.0		7,680	\$1,294.93	\$1,304.80	\$2,599.73	31	0.26
2022	Nov		29.6		7,280	\$838.79	\$1,038.25	\$1,877.04	30	0.34
2022	Dec		22.4		7,360	\$527.19	\$836.74	\$1,363.93	31	0.44
<b>2022 Totals</b>		<b>\$0.00</b>	<b>417.6</b>	<b>\$0.00</b>	<b>112,400</b>	<b>\$11,431.29</b>	<b>\$14,261.69</b>	<b>\$25,692.98</b>	<b>365</b>	<b>0.03</b>

**Table Formulas:**

Hours per Month (h) = G x 24  
 Total Cost (F) = B + D + E  
 Load Factor (H) = C / (A x h)

**Summary**

Energy Intensity (kWh/sq.ft.):	8.50
Cost Intensity (\$/sq.ft.):	\$1.94
Blended Cost (inc.demand) / kWh:	\$0.229
<b>Avg. Cost / kWh:</b>	<b>\$0.00</b>
<b>Avg. Cost / kWh:</b>	<b>\$0.2286</b>

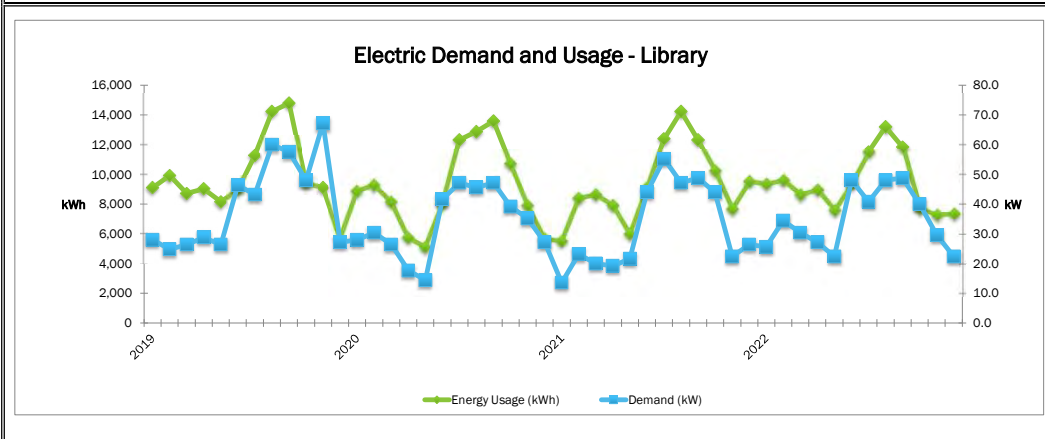

Building Name: **Village Hall & Library**  
 Address: **7 Maple Ave**  
**Hastings on Hudson, NY 10706**  
 Facility Area: **23,820** sq.ft.



Date: **7/11/2023**  
 Utility Company: **ConEdison**  
 Acct. No.: **59-0906-2764-3500-9**  
 Meter: **3861892**  
 Rate: **GS2 Rate II Non-residential**

**ANNUAL FUEL UTILITY DATA**

Billing Year	Billing Month	Customer Charge	Natural Gas Usage (Therms)	Fuel Oil #2 Usage (Gal)	Propane Usage (Gal)	Usage Supply Cost	Usage Delivery Cost	Total Cost	mmBtu Equivalent	Billing Days
2019	Jan		3,842			\$0.00	\$0.00	\$0.00	384.20	31
2019	Feb		3,055			\$0.00	\$0.00	\$0.00	305.50	28
2019	Mar		2,329			\$0.00	\$0.00	\$0.00	232.90	31
2019	Apr		1,124			\$0.00	\$0.00	\$0.00	112.40	30
2019	May		72			\$0.00	\$0.00	\$0.00	7.20	31
2019	Jun		4			\$0.00	\$0.00	\$0.00	0.40	30
2019	Jul		2			\$0.00	\$0.00	\$0.00	0.20	31
2019	Aug		3			\$0.00	\$0.00	\$0.00	0.30	30
2019	Sep		5			\$0.00	\$0.00	\$0.00	0.50	31
2019	Oct		2,279			\$0.00	\$0.00	\$0.00	227.90	31
2019	Nov		2,675			\$0.00	\$0.00	\$0.00	267.50	30
2019	Dec		2,360			\$0.00	\$0.00	\$0.00	236.00	31
2020	Jan		3,640			\$0.00	\$0.00	\$0.00	364.00	31
2020	Feb		4,872			\$0.00	\$0.00	\$0.00	487.20	28
2020	Mar		2,280			\$0.00	\$0.00	\$0.00	228.00	31
2020	Apr		2,751			\$0.00	\$0.00	\$0.00	275.10	30
2020	May		72			\$0.00	\$0.00	\$0.00	7.20	31
2020	Jun		72			\$0.00	\$0.00	\$0.00	7.20	30
2020	Jul		2			\$0.00	\$0.00	\$0.00	0.20	31
2020	Aug		3			\$0.00	\$0.00	\$0.00	0.30	30
2020	Sep		141			\$0.00	\$0.00	\$0.00	14.10	31
2020	Oct		192			\$0.00	\$0.00	\$0.00	19.20	31
2020	Nov		2,299			\$0.00	\$0.00	\$0.00	229.90	30
2020	Dec		3,637			\$0.00	\$0.00	\$0.00	363.70	31
2021	Jan		3,567			\$0.00	\$0.00	\$0.00	356.70	31
2021	Feb		2,471			\$0.00	\$0.00	\$0.00	247.10	28
2021	Mar		1,810			\$0.00	\$0.00	\$0.00	181.00	31
2021	Apr		988			\$0.00	\$0.00	\$0.00	98.80	30
2021	May		8			\$0.00	\$0.00	\$0.00	0.80	31
2021	Jun		8			\$0.00	\$0.00	\$0.00	0.80	30
2021	Jul		6			\$0.00	\$0.00	\$0.00	0.60	31
2021	Aug		10			\$0.00	\$0.00	\$0.00	1.00	30
2021	Sep		10			\$0.00	\$0.00	\$0.00	1.00	31
2021	Oct		554			\$0.00	\$0.00	\$0.00	55.40	31
2021	Nov		2,524			\$0.00	\$0.00	\$0.00	252.40	30
2021	Dec		2,299			\$0.00	\$0.00	\$0.00	229.90	31
2022	Jan		2,827			\$1,959.00	\$2,719.00	\$4,678.00	282.70	31
2022	Feb		3,312			\$2,195.00	\$2,556.00	\$4,751.00	331.20	28
2022	Mar		2,780			\$1,822.00	\$2,534.00	\$4,356.00	278.00	31
2022	Apr		1,902			\$1,377.00	\$1,744.00	\$3,121.00	190.20	30
2022	May		1,128			\$1,013.00	\$956.00	\$1,969.00	112.80	31
2022	Jun		54			\$57.00	\$105.00	\$162.00	5.40	30
2022	Jul		0			\$0.00	\$38.80	\$38.80	0.00	31
2022	Aug		0			\$0.00	\$35.00	\$35.00	0.00	30
2022	Sep		0			\$0.00	\$36.00	\$36.00	0.00	31
2022	Oct		0			\$368.00	\$518.60	\$886.60	0.00	31
2022	Nov		410			\$2,438.00	\$2,821.00	\$5,259.00	41.00	30
2022	Dec		2,950			\$3,577.00	\$3,328.00	\$6,905.00	295.00	31
<b>2022 Totals</b>		\$0.00	<b>15,363</b>	<b>0.0</b>	<b>0.0</b>	<b>\$14,806.00</b>	<b>\$17,391.40</b>	<b>\$32,197.40</b>	<b>1536.30</b>	<b>365</b>

**Table Formulas:**  
 mmBtu Equivalent (G) = Natural Gas Therms (A) / 10  
 mmBtu Equivalent (G) = Fuel Oil #2 Gallons (B) x 0.14  
 mmBtu Equivalent (G) = Propane Gallons (C) x 0.096  
 Total Cost (F) = D + E

Summary	
Energy Intensity (mmBtu/sq.ft.):	0.0645
Cost Intensity (\$/sq.ft.):	\$1.35
<b>Avg. Cost / therm:</b>	<b>\$2.10</b>
<b>Avg. Cost / Gal of Fuel Oil:</b>	<b>N/A</b>
<b>Avg. Cost / Gal of Propane:</b>	<b>N/A</b>
<b>Avg. Cost / mmBtu:</b>	<b>\$20.9578</b>

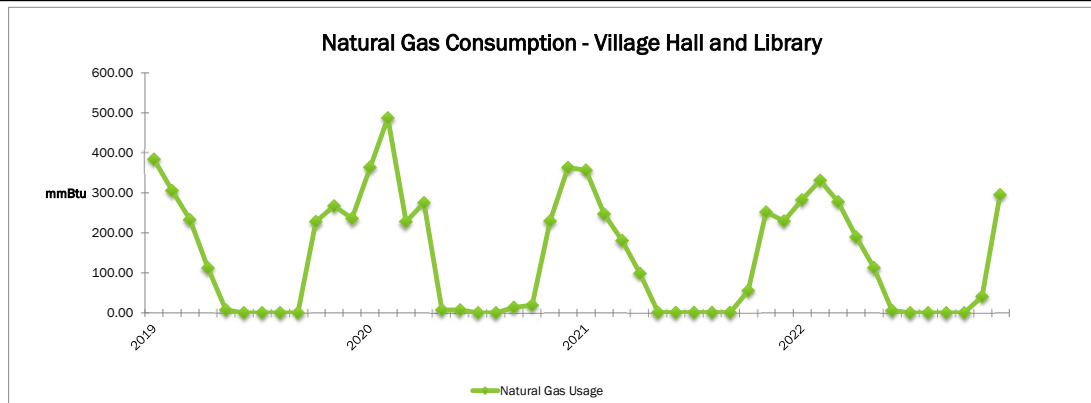



# appendix 2

---

existing equipment  
inventory

**HVAC SYSTEM OVERVIEW | INTERVIEW SUMMARY**

ASHRAE 21.1-2018 [Modified by Wendel]

Commercial Building Energy Audit Sample Forms

Level 2 Audit - HVAC System					
HVAC Properties (check all that apply)					
<b>Cooling Source*</b>	<input type="checkbox"/> No cooling <input checked="" type="checkbox"/> DX cooling <input type="checkbox"/> Central plant <input type="checkbox"/> Chiller <i>Add chiller details</i> <input type="checkbox"/> District chilled water <input type="checkbox"/> Water-side Economizer <input type="checkbox"/> Other (specify) _____	<b>Chiller Input*</b> <input type="checkbox"/> Electricity <input type="checkbox"/> Gas <input type="checkbox"/> Oil (specify grade) <input type="checkbox"/> Other	<input type="checkbox"/> Gas Absorption <input type="checkbox"/> Steam Absorption <input type="checkbox"/> Steam Turbine		
		<b>Compressor*</b> <input type="checkbox"/> Reciprocating <input type="checkbox"/> Other	<input type="checkbox"/> Scroll/Screw <input type="checkbox"/> Centrifugal		
		<b>Condenser*</b> <input checked="" type="checkbox"/> Air <input type="checkbox"/> Indirect Evaporative <input type="checkbox"/> Water <input type="checkbox"/> Direct Evaporative <input type="checkbox"/> Ground			
<b>Heating Source*</b>	<input type="checkbox"/> No heating <input type="checkbox"/> Central furnace <input type="checkbox"/> Heat pump <input checked="" type="checkbox"/> Central plant <i>Add Boiler details</i> <input type="checkbox"/> District steam or hot water <input type="checkbox"/> Other (specify) _____	<b>Heating fuel*</b> <input type="checkbox"/> Electricity <input checked="" type="checkbox"/> Gas <input checked="" type="checkbox"/> Oil (specify grade) <i>Not used in recent years. Half full</i> <input type="checkbox"/> Other			
		<b>Boiler Type*</b> <input checked="" type="checkbox"/> Steam boiler <input type="checkbox"/> Hydronic boiler <input type="checkbox"/> Forced draft <input type="checkbox"/> Other Draft Type			
<b>SHW/DHW Source*</b>	<input type="checkbox"/> No DHW <input type="checkbox"/> Indirect fired <input type="checkbox"/> Storage <input type="checkbox"/> Instantaneous <input checked="" type="checkbox"/> Direct fired <input checked="" type="checkbox"/> Storage <input type="checkbox"/> Instantaneous <input type="checkbox"/> Heat pump <input type="checkbox"/> Other	<b>SHW/DHW fuel*</b> <input checked="" type="checkbox"/> Electricity <input type="checkbox"/> Gas <input type="checkbox"/> Oil (specify grade) _____ <input type="checkbox"/> Other: _____			
<b>Cooling Terminal Equipment Type*</b>	<input checked="" type="checkbox"/> N/A		25%		
	<input type="checkbox"/> Hydronic to zone equipment (e.g. fan coil units, Chilled Beam)		0%		
	<input checked="" type="checkbox"/> Packaged Refrigerant equipment (e.g. Split Systems, packaged terminal unit)		75%		
	<input type="checkbox"/> Refrigerant to zone equipment (e.g. VRF System)		0%		
	<input type="checkbox"/> Water Source Heat Pump System		0%		
<b>Heating Terminal Equipment Type*</b>	<input type="checkbox"/> N/A		0%		
	<input type="checkbox"/> Hydronic to zone equipment (e.g. fan coil units, VAV RH, radiators)		0%		
	<input checked="" type="checkbox"/> Steam zone equipment (e.g. radiators)		95%		
	<input type="checkbox"/> Refrigerant to zone equipment (e.g. VRF System)		0%		
	<input checked="" type="checkbox"/> Water Source or Air Source Heat Pump System		5%		
<b>Zone Controls</b>	<input type="checkbox"/> Direct Digital (DDC)	0%	<b>Central Plant Controls</b>	<input type="checkbox"/> Updated Controllers	0%
	<input type="checkbox"/> Pnuematic	0%		<input type="checkbox"/> Direct Digital (DDC)	0%
	<input type="checkbox"/> Programmable tstats	0%		<input checked="" type="checkbox"/> Pnuematic	10%
	<input checked="" type="checkbox"/> Manual tstats	100%		<input checked="" type="checkbox"/> Other	90%
<b>AHU TYPE 1 SYSTEM TYPE</b>	<b>Number of Units</b>	1	<b>Heating Source</b>	<input type="checkbox"/> Steam <input type="checkbox"/> Hot Water <input type="checkbox"/> Glycol Water <input type="checkbox"/> Natural Gas Burner	<input checked="" type="checkbox"/> N/A <input type="checkbox"/> Other (Add description in notes) <input type="checkbox"/> Heat Pump (Water Source) <input type="checkbox"/> Heat Pump (Air Source)
	<input type="checkbox"/> Variable Air Volume (VAV) <input checked="" type="checkbox"/> Constant Volume (CV) <input type="checkbox"/> Dual Duct (DD) <input type="checkbox"/> Multizone (MZ) <input type="checkbox"/> Induction (ID) <input type="checkbox"/> Other (Add description in notes)	<b>Cooling Source</b>	<input checked="" type="checkbox"/> DX <input type="checkbox"/> Chilled Water <input type="checkbox"/> DX / Process CW <input type="checkbox"/> Adiabatic Cooling	<input type="checkbox"/> N/A <input type="checkbox"/> Other (Add description in notes) <input type="checkbox"/> Heat Pump (Water Source) <input type="checkbox"/> Heat Pump (Air Source)	
<b>Air Flow Type</b>	<input type="checkbox"/> Dedicated Outdoor Air (DOAs) <input checked="" type="checkbox"/> Mixed Air Unit (H Patern) <input type="checkbox"/> Air Turn Over (no Outdoor Air) <input type="checkbox"/> Other (Add description in notes)	<b>Ventilation Controls</b>	<input checked="" type="checkbox"/> Fixed Ventilation Rate <input type="checkbox"/> Demand Controlled Ventilation <input type="checkbox"/> Schedule Ventilation <input type="checkbox"/> Other (Add description in notes)		
<b>Economizer*</b>	<input type="checkbox"/> Temperature Economizer <input type="checkbox"/> Enthalpy Economizer <input checked="" type="checkbox"/> No Functioning Economizer <input type="checkbox"/> Dedicated OA System	<b>Heat Recovery</b>	<input type="checkbox"/> Enthalpy <input type="checkbox"/> Sensible (Temp Only)		
		<b>Scheduled</b>	<input type="checkbox"/> N/A <input checked="" type="checkbox"/> Temperature Setback <input type="checkbox"/> Temp & Vent Setback <input type="checkbox"/> Cycles off		
<b>Exhaust Fans</b>	<input checked="" type="checkbox"/> No Mechanical Exhaust (natural only, i.e. windows, doors or gravity shafts) <input type="checkbox"/> Exhaust Fans Only <input type="checkbox"/> Supply and Exhaust Fans	<b>Scheduled</b>	<input checked="" type="checkbox"/> N/A <input type="checkbox"/> Temperature Setback	<input type="checkbox"/> Temp & Vent Setback <input type="checkbox"/> Cycles off	



**HVAC SYSTEM OVERVIEW | INTERVIEW SUMMARY**

ASHRAE 21.1-2018 [Modified by Wendel]

Commercial Building Energy Audit Sample Forms

Level 2 Audit - HVAC System					
HVAC Properties (check all that apply)					
<b>Cooling Source*</b>	<input type="checkbox"/> No cooling <input checked="" type="checkbox"/> DX cooling <input type="checkbox"/> Central plant <input checked="" type="checkbox"/> Chiller <i>Add chiller details</i> <input type="checkbox"/> District chilled water <input type="checkbox"/> Water-side Economizer <input type="checkbox"/> Other (specify) _____	<b>Chiller Input*</b> <input checked="" type="checkbox"/> Electricity <input type="checkbox"/> Gas Absorption <input type="checkbox"/> Gas <input type="checkbox"/> Steam Absorption <input type="checkbox"/> Oil (specify grade) <input type="checkbox"/> Steam Turbine <input type="checkbox"/> Other			
		<b>Compressor*</b> <input type="checkbox"/> Reciprocating <input checked="" type="checkbox"/> Scroll/Screw <input type="checkbox"/> Centrifugal <input type="checkbox"/> Other			
		<b>Condenser*</b> <input checked="" type="checkbox"/> Air <input type="checkbox"/> Water <input type="checkbox"/> Ground <input type="checkbox"/> Indirect Evaporative <input type="checkbox"/> Direct Evaporative			
<b>Heating Source*</b>	<input type="checkbox"/> No heating <input type="checkbox"/> Central furnace <input type="checkbox"/> Heat pump <input type="checkbox"/> Central plant <i>Add Boiler details</i> <input checked="" type="checkbox"/> District steam or hot water <input type="checkbox"/> Other (specify) _____	<b>Heating fuel*</b> <input type="checkbox"/> Electricity <input checked="" type="checkbox"/> Gas <b>Not used in recent years. Half full</b> <input checked="" type="checkbox"/> Oil (specify grade) <input type="checkbox"/> Other			
		<b>Boiler Type*</b> <input checked="" type="checkbox"/> Steam boiler <input type="checkbox"/> Forced draft <input type="checkbox"/> Hydronic boiler <input type="checkbox"/> Other Draft Type			
<b>SHW/DHW Source*</b>	<input type="checkbox"/> No DHW <input type="checkbox"/> Indirect fired <input type="checkbox"/> Storage <input type="checkbox"/> Instantaneous <input checked="" type="checkbox"/> Direct fired <input checked="" type="checkbox"/> Storage <input type="checkbox"/> Instantaneous <input type="checkbox"/> Heat pump <input type="checkbox"/> Other	<b>SHW/DHW fuel*</b> <input checked="" type="checkbox"/> Electricity <input type="checkbox"/> Gas <input type="checkbox"/> Oil (specify grade) _____ <input type="checkbox"/> Other: _____			
<b>Cooling Terminal Equipment Type*</b>	<input checked="" type="checkbox"/> N/A		75%		
	<input type="checkbox"/> Hydronic to zone equipment (e.g. fan coil units, Chilled Beam)		0%		
	<input type="checkbox"/> Packaged Refrigerant equipment (e.g. Split Systems, packaged terminal unit)		0%		
	<input type="checkbox"/> Refrigerant to zone equipment (e.g. VRF System)		0%		
	<input checked="" type="checkbox"/> Air Source Heat Pump System		25%		
<b>Heating Terminal Equipment Type*</b>	<input type="checkbox"/> N/A		0%		
	<input checked="" type="checkbox"/> Hydronic to zone equipment (e.g. fan coil units, VAV RH, radiators)		75%		
	<input type="checkbox"/> Steam zone equipment (e.g. radiators)		0%		
	<input type="checkbox"/> Refrigerant to zone equipment (e.g. VRF System)		0%		
	<input checked="" type="checkbox"/> Water Source or Air Source Heat Pump System		25%		
<b>Zone Controls</b>	<input type="checkbox"/> Direct Digital (DDC)	0%	<b>Central Plant Controls</b>	<input type="checkbox"/> Updated Controllers	0%
	<input checked="" type="checkbox"/> Pnuematic	100%		<input type="checkbox"/> Direct Digital (DDC)	0%
	<input type="checkbox"/> Programmable tstats	0%		<input checked="" type="checkbox"/> Pnuematic	10%
	<input type="checkbox"/> Manual tstats	0%		<input checked="" type="checkbox"/> Other	90%
<b>AHU TYPE 1 SYSTEM TYPE</b>	<b>Number of Units</b>	1	<b>Heating Source</b>	<input type="checkbox"/> Steam	<input type="checkbox"/> N/A
	<input type="checkbox"/> Variable Air Volume (VAV) <input type="checkbox"/> Constant Volume (CV) <input type="checkbox"/> Dual Duct (DD) <input checked="" type="checkbox"/> Multizone (MZ) <input type="checkbox"/> Induction (ID) <input type="checkbox"/> Other (Add description in notes)	<input checked="" type="checkbox"/> Hot Water <input type="checkbox"/> Glycool Water <input type="checkbox"/> Natural Gas Burner <input type="checkbox"/> Other (Add description in notes)		<input type="checkbox"/> Heat Pump (Water Source) <input type="checkbox"/> Heat Pump (Air Source)	
			<b>Cooling Source</b>	<input checked="" type="checkbox"/> DX <input type="checkbox"/> Chilled Water <input type="checkbox"/> DX / Process CW <input type="checkbox"/> Adiabatic Cooling	<input type="checkbox"/> N/A <input type="checkbox"/> Other (Add description in notes) <input type="checkbox"/> Heat Pump (Water Source) <input type="checkbox"/> Heat Pump (Air Source)
<b>Air Flow Type</b>	<input type="checkbox"/> Dedicated Outdoor Air (DOAs) <input checked="" type="checkbox"/> Mixed Air Unit (H Patern) <input type="checkbox"/> Air Turn Over (no Outdoor Air) <input type="checkbox"/> Other (Add description in notes)		<b>Ventilation Controls</b>	<input type="checkbox"/> Fixed Ventilation Rate <input type="checkbox"/> Demand Controlled Ventilation <input type="checkbox"/> Schedule Ventilation <input type="checkbox"/> Other (Add description in notes)	
<b>Economizer*</b>	<input checked="" type="checkbox"/> Temperature Economizer <input type="checkbox"/> Enthalpy Economizer <input type="checkbox"/> No Functioning Economizer <input type="checkbox"/> Dedicated OA System		<b>Heat Recovery</b>	<input type="checkbox"/> Enthalpy <input type="checkbox"/> Sensible (Temp Only)	
			<b>Scheduled</b>	<input type="checkbox"/> N/A <input type="checkbox"/> Temperature Setback	<input type="checkbox"/> Temp & Vent Setback <input type="checkbox"/> Cycles off
<b>Exhaust Fans</b>	<input checked="" type="checkbox"/> No Mechanical Exhaust (natural only, i.e. windows, doors or gravity shafts) <input type="checkbox"/> Exhaust Fans Only <input type="checkbox"/> Supply and Exhaust Fans		<b>Scheduled</b>	<input checked="" type="checkbox"/> N/A <input type="checkbox"/> Temperature Setback	<input type="checkbox"/> Temp & Vent Setback <input type="checkbox"/> Cycles off



**Level 2 Audit - Equipment Inventory - Heating Equipment**

**NOTES**

(1) Per ASHRAE requirements, the equipment inventory shall include equipment that represents, in aggregate, 80% or more of the energy use allocated to HVAC & SHW/DHW in the end-use allocation

(2) Note to the reader. Some values are either calculated or estimated based on the best available data. These values are shown in italics and the cell is noted.

Project: GSHP Study  
Building: Village of Hastings-on-Huds

Field	Field	Field	Field	Field	Field	Field	Field	Field	Office	Field	Field	Field	Field	Field
Boiler Group 1														
BOILERS	ID	Manufacturer	Model Number	Location	Area/System Served	Heating System Type	Boiler Type	Fuel Type	Full Load Efficiency (DWgs. / O&Ms)	Heating Capacity (MBH)	Exhaust Flue Type	Burner Controls	Approx Year Installed	Overall Exterior Condition
	B-1	Weil McLain	1088	Village Hall Boiler Room	Heating System - Village Hall and	Steam System	Steam Boiler	Duel Fuel NG/#2	79%	2452	TBD	Powerflame	1983-1985	Good - No Visible Leaks/Rust/Breakage
	WH-1	AO Smith	LTE-80D 200	Village Hall Boiler Room	Village Hall - DHW	DHW	Electric Boiler	Electric	-	11.53256	N/A	N/A	2017	Good - No Visible Leaks/Rust/Breakage
WH-2	American	E6N-40R 110	Library Telecom Room	Library - DHW	DHW	Electric Boiler	Electric	0.92 UEF	11.5155	N/A	N/A	2017	Good - No Visible Leaks/Rust/Breakage	
HEAT	ID	Manufacturer	Model Number	Location	Area/System Served	HOT SIDE HX	COLD SIDE HX	NOT USED	NOT USED	Heating Capacity (MBH)	NOT USED	NOT USED	Approx Year Installed	Overall Exterior Condition
	HX-1	B&G	SU 43-2	Village Hall Basement	Library Heating System	Steam System	Hot Water			97.5			1999	Good - No Visible Leaks/Rust/Breakage
HX-2	-	-	Village Hall Basement	Locker Room Heating System	Steam System	Hot Water			-				-	Out of Service
PRIMARY HW PUMPS	ID	Manufacturer	Model Number	Location	Area/System Served	Pump Type	Pump GPM	Pump Head	Motor HP	Motor Eff.	Voltage	Speed Control	Approx Year Installed	Overall Exterior Condition
	PHW-1	B&G	Series 1531 No 1 1/2 AB	Village Hall Basement	Library Hot Water Loop	End suction	75	45	1.25	76.00%	208	No	TBD	Good - No Visible Leaks/Rust/Breakage
	PHW-2	B&G	Series 1531 No 1 1/2 AB	Village Hall Basement	Library Hot Water Loop	End suction	75	45	1.25	76.00%	208	No	TBD	Good - No Visible Leaks/Rust/Breakage
	P-1	B&G	Series 60 1'AA	Village Hall Boiler Room	Village Hall Hot Water Loop	Circulator	10	15	0.25	60.00%	115	No	1999	Out of Service
P-2	B&G	Series 60 1'AA	Village Hall Boiler Room	Village Hall Hot Water Loop	Circulator	10	15	0.25	60.00%	115	No	1999	Out of Service	
SECONDARY HW	ID	Manufacturer	Model Number	Location	Area/System Served	Pump Type	Pump GPM	Pump Head	Motor HP	Motor Eff.	Voltage	Speed Control	Approx Year Installed	Overall Exterior Condition
	Steam Traps	-	36-40 total traps	Terminal Units & MERs	Steam	N/A	N/A	N/A	N/A	N/A	N/A	N/A	Recent	Good - No Visible Leaks/Rust/Breakage
	BFU-1	Domestic Pump ITT	52 CBM 12-30	Village Hall Boiler Room	Boiler Fuel Oil Transfer Unit	Fuel Oil	12	591	2	80.60%	208	No	1999	Good - No Visible Leaks/Rust/Breakage
	DWRP-1	B&G	Series 100 BNFI K31	Village Hall Basement	DHW	Circulator	-	-	0.083333333	60.00%	115	No	-	Good - No Visible Leaks/Rust/Breakage
DWRP-2	-	-	Library Telecom Room	DHW	Circulator	-	-	-	60.00%	115	No	-	-	
CON	ID	Manufacturer	Model Number	Location	Area/System Served	Pump Type	Pump GPM	Pump Head	Motor HP	Motor Eff.	Voltage	Speed Control	Approx Year Installed	Overall Exterior Condition
CTU-1	FloTronics	CRHC2-15	Village Hall Boiler Room	Boiler	Condensate Pump Set	15	79	0.5	60.00%	115	No	-	Good - No Visible Leaks/Rust/Breakage	

**Level 2 Audit - Equipment Inventory - Chilled Water Equipment**

**NOTES**  
 (1) Per ASHRAE requirements, the equipment inventory shall include equipment that represents, in aggregate, 80% or more of the energy use allocated to HVAC & SHW/DHW in the end-use allocation  
 (2) Note to the reader. Some values are either calculated or estimated based on the best available data. These values are shown in italics and the cell is noted.  
 Project: GSHP Study  
 Building: Village of Hastings-on-Hudson

Field	Field	Field	Field	Field	Field	Field	Field	Office	Office	Field	Field	Field	Field	Field	Field
Chiller Group 1															
	ID	Manufacturer	Model Number	Location	Area/System Served	Chiller Type	Compressor Type	Full Load Efficiency (DWgs. / O&Ms)	IPLV (DWGs. / O&Ms)	Cooling Capacity (Tons)	Voltage	Refrigerant	Speed Control	Approx Year Installed	Overall Exterior Condition
<b>CHIL</b>	CH-1	Trane	CGAD040GAF19GT		Main floor, Picture Book	Air-Cooled	Scroll	10.5 EER	-	36.1	208	R-22	No	1990s	Average - Minor Visible Leaks/Rust/Breakage
	ID	Manufacturer	Model Number	Location	Area/System Served	Pump Type	Pump GPM	Pump Head	Motor HP	Motor Eff.	Voltage	Not Used	Speed Control	Approx Year Installed	Overall Exterior Condition
<b>PRIMARY</b>	PCHW-1	B&G	Series 1531 No 2 AB	Penthouse Equipment Room	Primary Chilled Water Loop	End suction	88	32	1.5	77.95%	208		No	1965	Good - No Visible Leaks/Rust/Breakage
	PCHW-2	B&G	Series 1531 No 2 AB	Penthouse Equipment Room	Primary Chilled Water Loop	End suction	88	32	1.5	77.95%	208		No	1965	Good - No Visible Leaks/Rust/Breakage



Level 2 Audit - Equipment Inventory - Terminal Equipment Type

NOTES

(1) Per ASHRAE requirements, the equipment inventory shall include equipment that represents, in aggregate, 80% or more of the energy use allocated to HVAC & SHW/DHW in the end-use allocation (2) Note to the reader. Some values are either calculated or estimated based on the best available data. These values are shown in italics and the cell is noted.

Project: GSHP Study  
Building: Village of Hastings

Office	Office	Office	Office	Office	Field	Field	Office	Office	Office	Office	Office	Office	Office	Office	Office	Office	Office
--------	--------	--------	--------	--------	-------	-------	--------	--------	--------	--------	--------	--------	--------	--------	--------	--------	--------

SYSTEM DETAILS														Air Flow Properties			
Unit Type ID	Unit Type	Estimated Quantity	Approx Year Installed	Area Served	Overall Exterior Condition	HVAC Control Type	Rated efficiency (as applicable)	Heating			Cooling			Supply Air Flow			Outdoor Air Flow
								Type	Valve Type	Capacity (MBH)	Type	Valve Type	Capacity (Tons)	CFM	Supply HP	Supply Fan VFD?	CFM
Friedrich	Through-Wall AC Units	11	<15 years	Offices	Average - Minor Visible Leaks/Rust/Breakage	Thermostat (Stand Alone)	8.5 EER	N/A	N/A	N/A	DX	N/A	0.50	200	0.03	No	0
PTAC-Finance	PTAC Units	1	<15 years	Finance (Summer)	Good - No Visible Leaks/Rust/Breakage	Thermostat (Stand Alone)	11.2 EER	N/A	N/A	N/A	DX	N/A	1.25	420	0.06	2-Speed	0
PTAC-Server	PTAC Units	1	<15 years	Server (Year-rnd)	Good - No Visible Leaks/Rust/Breakage	Thermostat (Stand Alone)	11.6 EER	N/A	N/A	N/A	DX	N/A	0.98	341	0.05	2-Speed	0
Split AC-1	Split System AC Units	1	<15 years	Police Station	Good - No Visible Leaks/Rust/Breakage	Thermostat (Stand Alone)	19.2 SEER & 10.5 EER	N/A	N/A	N/A	DX	N/A	1.50	533	0.04	Multi-Speed	0
Split AC-2	Split System AC Units	1	<15 years	911 Closet	Good - No Visible Leaks/Rust/Breakage	Thermostat (Stand Alone)	19.2 SEER & 10.5 EER	N/A	N/A	N/A	DX	N/A	1.50	533	0.04	Multi-Speed	0
Split HP-1	Split System AC Units	1	<15 years	Police Station	Good - No Visible Leaks/Rust/Breakage	Thermostat (Stand Alone)	19.2 SEER & 10.5 EER	Heat Pump	N/A	18.00	DX	N/A	1.50	533	0.04	Multi-Speed	0
Steam Radiators	Radiators	38	>20 years	1st and Second Floor Perimeter	Average - Minor Visible Leaks/Rust/Breakage	USER	N/A	Steam	2-Way	352.00	N/A	N/A	N/A	N/A	N/A	N/A	N/A
HW Radiators	Radiators	Perimeter	-	Police Locker Room	Out of Service	Out of Service	N/A	HW	3-Way	1.87 BTU/Ft (2 tiers)	N/A	N/A	N/A	N/A	N/A	N/A	N/A
CUH-1	Unit Heaters	1	-	Police Locker Room	Out of Service	Out of Service	N/A	Hot Water	3-Way	30.8-34.9	N/A	N/A	N/A	265-330	0.07	2-Speed	N/A
AC-2 (Ducted Split)	Split System AC Units	1	2014	Off Community Room & 60% of lower level	Average - Minor Visible Leaks/Rust/Breakage	Thermostat (Pnumatic) / BMS	0.98 kW/Ton heat 1.02 kW/Ton cool	Heat Pump	N/A	108.00	DX	N/A	8.00	989-1201-1412 x2	0.20	3-Speed	565
AC-3-Director	Split System AC Units	1	2019	Director's Office	Good - No Visible Leaks/Rust/Breakage	Thermostat (Pnumatic) / BMS	13.5 EER	Heat Pump	N/A	6.29	DX	N/A	0.50	194-497	0.06	Multi-Speed	0
AC-3-Children	Split System AC Units	1	2019	Children's Room	Good - No Visible Leaks/Rust/Breakage	Thermostat (Pnumatic) / BMS	13.5 EER	Heat Pump	N/A	15.71	DX	N/A	1.25	117-437	0.06	Multi-Speed	0
HW Radiators - Library	Radiators	147.5' (26 Units)	1965	1st Floor Perimeter	Good - No Visible Leaks/Rust/Breakage	Thermostat (Pnumatic) / BMS	N/A	HW	TBD	210.92	N/A	N/A	N/A	N/A	N/A	N/A	N/A
UH-1	Unit Heaters	1	1965	Basement Lobby	Good - No Visible Leaks/Rust/Breakage	Thermostat (Pnumatic) / BMS	N/A	HW	TBD	15.30	N/A	N/A	N/A	400	0.25	No	N/A
UH-2	Unit Heaters	1	1965	Penthouse Equipment Rm	TBD	Thermostat (Pnumatic) / BMS	N/A	HW	TBD	20.00	N/A	N/A	N/A	591	0.05	No	N/A

**Level 2 Audit - HVAC CONTROLS STRATEGY**

**NOTES**

(1) Per ASHRAE requirements, the equipment inventory shall include equipment that represents, in aggregate, 80% or more of the energy use allocated to HVAC & SHW/DHW in the

Project: GSHP Study  
 Building: Village of Hastings-on-Hudson

Interview	Field	Field	Office	Office	BMS System	BMS System	BMS System	BMS System	BMS System	BMS System
-----------	-------	-------	--------	--------	------------	------------	------------	------------	------------	------------

SYSTEM DETAILS					CONTROLS					
ID #	Central HVAC Type		Terminal Unit Type	Area/System Served	Schedule (M-F)	Schedule (Weekend / Holiday)	Schedule Control	Ventilation Control	Supply Air Temperature Control	Economizer Control
	AHU Configuration	System								
AC-1	Mixed Air Unit	CV	Radiators	Courtroom	9AM-5PM	Off	Temperature Setback	Fixed	Fixed Setpoint	N/A
HV-1	Mixed Air Unit	MZ	Radiators	Library Main Floor	M-TH: 8AM-7PM, F: 8AM-5PM	S: 8AM:2PM, SU: Off, Holidays: 4/2,12/24,12/25,7/4,11/23-25	Temperature Setback	Fixed	Reset based on OA	Drybulb Economizer
Friedrich	N/A	N/A	Through-Wall AC Units	Offices	USER	USER	Cycle Off	N/A	Fixed Setpoint	N/A
PTAC-Finance	N/A	N/A	PTAC Units	Finance (Summer)	USER	USER	Cycle Off	N/A	Fixed Setpoint	N/A
PTAC-Server	N/A	N/A	PTAC Units	Server (Year-rnd)	24/7	24/7	24/7	N/A	Fixed Setpoint	N/A
Split AC-1	N/A	N/A	Split System AC Units	Police Station	24/7	24/7	24/7	N/A	Fixed Setpoint	N/A
Split AC-2	N/A	N/A	Split System AC Units	911 Closet	24/7	24/7	24/7	N/A	Fixed Setpoint	N/A
Split HP-1	N/A	N/A	Split System AC Units	Police Station	24/7	24/7	24/7	N/A	Fixed Setpoint	N/A
Steam Radiators	N/A	N/A	Radiators	1st and Second Floor Perimeter	24/7	24/7	24/7	N/A	N/A	N/A
HW Radiators	N/A	N/A	Radiators	Police Locker Room	Out of Service	Out of Service	Out of Service	N/A	N/A	N/A
CUH-1	N/A	N/A	Unit Heaters	Police Locker Room	Out of Service	Out of Service	Out of Service	N/A	Fixed Setpoint	N/A
AC-2 (Ducted Split)	N/A	N/A	Split System AC Units	Orr Community Room & 60% of lower level	M-TH: 8AM-7PM, F: 8AM-5PM	S: 8AM:2PM, SU: Off, Holidays: 4/2,12/24,12/25,7/4,11/23-25	Temperature Setback	Fixed	Fixed Setpoint	N/A
AC-3-Director	N/A	N/A	Split System AC Units	Director's Office	M-TH: 8AM-7PM, F: 8AM-5PM	S: 8AM:2PM, SU: Off, Holidays: 4/2,12/24,12/25,7/4,11/23-25	Temperature Setback	N/A	Fixed Setpoint	N/A
AC-3-Children	N/A	N/A	Split System AC Units	Children's Room	M-TH: 8AM-7PM, F: 8AM-5PM	S: 8AM:2PM, SU: Off, Holidays: 4/2,12/24,12/25,7/4,11/23-25	Temperature Setback	N/A	Fixed Setpoint	N/A
HW Radiators - Library	N/A	N/A	Radiators	1st Floor Perimeter	M-TH: 8AM-7PM, F: 8AM-5PM	S: 8AM:2PM, SU: Off, Holidays: 4/2,12/24,12/25,7/4,11/23-25	Temperature Setback	N/A	N/A	N/A
UH-1	N/A	N/A	Unit Heaters	Basement Lobby	M-TH: 8AM-7PM, F: 8AM-5PM	S: 8AM:2PM, SU: Off, Holidays: 4/2,12/24,12/25,7/4,11/23-25	Temperature Setback	N/A	Fixed Setpoint	N/A
UH-2	N/A	N/A	Unit Heaters	Penthouse Equipment Rm	M-TH: 8AM-7PM, F: 8AM-5PM	S: 8AM:2PM, SU: Off, Holidays: 4/2,12/24,12/25,7/4,11/23-25	Temperature Setback	N/A	Fixed Setpoint	N/A



# appendix 3

---

energy savings  
calculations

MEASURE SUMMARY | Geothermal Heat Pump System



**Project Name:** Hastings on Hudson Village Geothermal Heat Pump Study  
**Building:** Library & Village Hall  
**Date:** 7/14/2023  
**EEM:** 1.1  
**Calculated By:** RM1  
**Reviewed By:** DTA

**Summary of Existing System**

Low Temp Hot Water AHUs & Baseboard Radiators in Library & Steam Perimeter Radiators in Village Hall. CHW Cooling in Library & Limited DX Cooling in Village Hall.

**Summary of Proposed System**

HW/CHW Heating and Cooling from Heat Recovery Heat Pumps with Geothermal Wells in the Library and a Neutral Temperature Loop to Local Heat Pumps with Geothermal Wells in the Village Hall. One Geothermal Well Field will be shared across both buildings.

**Measured Data**

Utility Data for Heating & Cooling Loads

**Data Limitations**

No submeters present to breakdown exact energy end uses, ASHRAE standards and previous project experience were used to disaggregate utilities.

**Conversions**

LP STM Enthalpy	1194 Btu/lb
Boilers Eff.	79%
System losses	2.5%

**Summary of Existing Systems Used for Calculation**

Existing System Summary			
Steam Utility Data	0 mmBTU	<b>A</b>	
Steam Utility Data	1,184 mmBTU	<b>B</b>	
Anticipated ECM Steam Savings	0 mmBTU	<b>C</b>	
<b>Adjusted Baseline Steam Use</b>	<b>1,184 mmBTU</b>	<b>D=B-C</b>	
Cooling Utility Data	0 mmBTU	<b>A</b>	
Cooling Utility Data	648 mmBTU	<b>B</b>	
Anticipated ECM Cooling Savings	0 mmBTU	<b>C</b>	
<b>Adjusted Baseline Cooling Use</b>	<b>648 mmBTU</b>	<b>D=B-C</b>	

**Proposed System Summary**

Heat Pump Cooling	648 mmBTU
Supplemental Cooling	0 mmBTU
Heat Pump Heating	1,184 mmBTU
Supplemental Heating	0 mmBTU
Pump Savings	-39,255 kWh
Heat Pump Electrical Savings	-143,639 kWh
Fan Savings	-1,772 kWh

**Energy Benefits**

**Basecase Savings Summary**

Cooling Savings	648 mmBtu
Electrical Savings	-184,665 kWh
Heating Savings	1,184 mmBTU

**Total Savings 1,202 mmBTU**

**Chilled Water & Steam Savings Summary**

Free Cooling Tons	2,032 Ton-Hrs
Electric Cooling Tons	51,970 Ton-Hrs
Steam Chiller Tons	0 Tons
<b>Total Offset Tons</b>	<b>54,002 Ton-Hrs</b>
Steam Savings Heating (Heat Pump)	992 klbs/Year
<b>Steam Savings Total</b>	<b>992 klbs/Year</b>

**Utility Savings Summary**

Cooling Electric Savings	61,183 kWh
Net Electric Savings	-123,482 kWh
Net Electric Savings	-421 mmBTU
Natural Gas	1,537 mmBTU
<b>Total Savings</b>	<b>1,116 mmBTU</b>
Current Natural Gas Usage	1,537 mmBTU
Proposed Natural Gas Usage	0 mmBTU
Reduction in Fossil Fuel Usage	100.0%

\*\*\*\* CONFIDENTIAL AND PROPRIETARY \*\*\*  
 Copyright © 2023 Wendel Energy Services, LLC. All Rights Reserved."





Project Name: Hastings on Hudson Village Geothermal Heat Pump Study  
 Building: Library & Village Hall  
 Date: 7/14/2023  
 EEM: 1.1  
 Scenario: HRC  
 Calculated By: RM1  
 Reviewed By: DTA

\*\*\*\* CONFIDENTIAL AND PROPRIETARY \*\*\*  
 Copyright © 2023 Wendel Energy Services, LLC. All Rights Reserved.

Existing Energy Summary	
Utility Baseline Cooling Use	648 mmBTU
Utility Baseline Steam Use	1,184 mmBTU
Adjusted Baseline Cooling Use	648 mmBTU
Adjusted Baseline Steam Use	1,184 mmBTU
Baseline Pump Usage	2,302 kWh
Proposed Energy Summary	
Cooling Savings	648 mmBTU
Supplemental Cooling	0 mmBTU
Heating Savings	1,184 mmBTU
Supplemental Heating	0 mmBTU
HRC Pump Savings	-39,255 kWh
HRC Electrical Savings	-143,639 kWh

Heat Recovery Chiller Performance Data				
	% Load	Cooling Cap. (Tons)	Input Power (kW)	Heat Rejection (MBH)
Summer	25.00	16.75	17.05	259.21
	50.00	33.51	33.45	516.2
	75.00	50.26	49.45	771.8
	100.00	67.01	65.80	1028.6
Winter	25.00	12.00	16.89	201.64
	50.00	24.01	33.11	401.1
	75.00	36.01	48.95	599.2
	100.00	48.02	65.13	798.5

System Enable Setpoints		
HP Enable Temp	-20	deg F
HW Enable Temp	-20	deg F
Month Start	January	0
Month End	December	12
Ex. Chiller Eff.	1.17	kW/ton
Load Safety Factor	100%	

Baseline Load Simulation & Reset Schedule		
OAT	HWST (°F)	CHWST (°F)
0	180	55
10	180	55
20	180	55
30	180	55
40	180	55
50	180	55
60	180	55
65	180	55
70	180	55
80	180	55
90	180	55
X=	80.00	Y= 180.00

Heat Pump / Geothermal Information		
Heat Pump Type	Standard	
Operation	Geothermal	
Geothermal Conductivity	2.5	ton/well
Geothermal Wells	20	wells
Total Capacity	50	Tons
Total Capacity	600	MBH
Heat Rejection Rate	1.21	btu/btu
Heat Absorption Rate	0.674	btu/btu

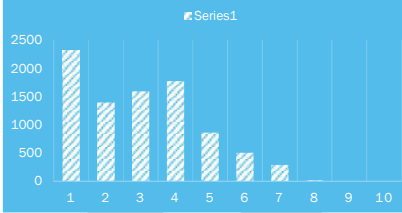

Summer to Winter Switch:	55
% Reference Performance	100%
# of Central Units	300
Tonnage Per Unit	10
# of Small Terminal Units	4500
Tonnage Per Unit	0.75
# of Large Terminal Units	300
Tonnage Per Unit	1.50

Heat Recovery Chiller Pump Information			
Pump Label	CHW Pumps Libr	HW Pumps Libr	Geo Pumps
Motor HP	0.75	1.5	15
Motor Eff	82%	86%	89%
Pump GPM	32.83	22.06	60.0
Pump Eff	60.7%	47.7%	47.8%
BHP	0.44	0.53	9.27
Ft. Hd.	32	45	292.5
QTY	2	2	2
kW	0.8	0.9	15.6
Control Type	W	W	W
Affinity Law Adj.	2.3	2.3	2.3

Central Plant Operations   CHW Eff.   STM to NG Eff.		
Boilers Eff.	79.0%	
Electric Chiller Eff.	1.17	kW/Ton
Steam Chiller Eff.	N/A	lbs/Ton
Free Cooling Eff.	0.30	kW/Ton
Free Cooling Enable	34	deg F (WB)
Free Cooling Capacity	1	tons
% CHW from STM	0%	

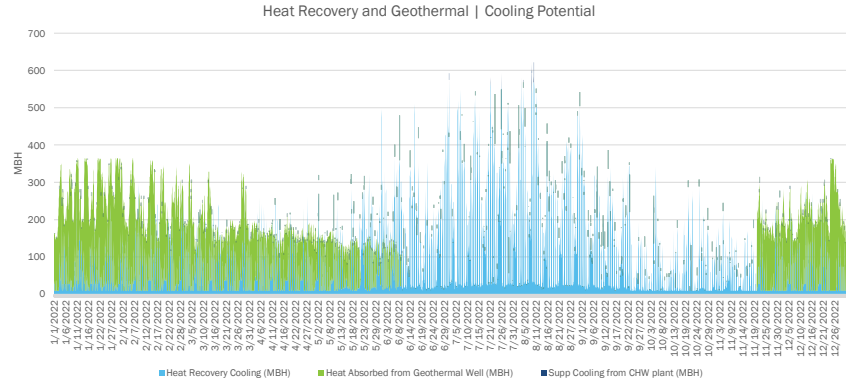
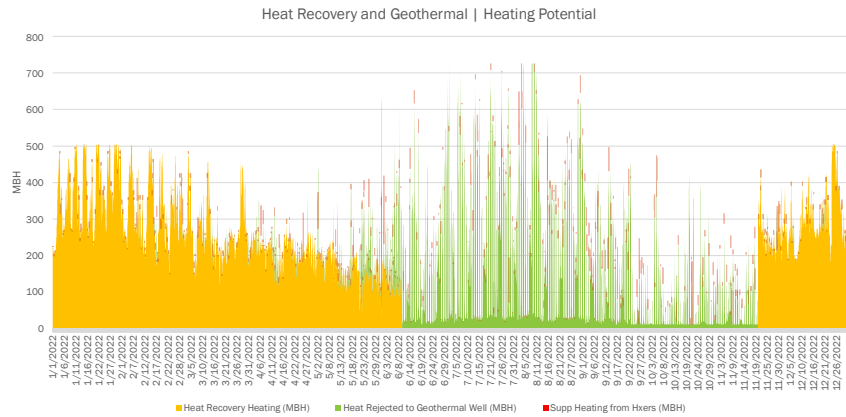



**Project Name:** Hastings on Hudson Village Geothermal Heat  
**Building:** Library & Village Hall  
**Date:** 7/14/2023  
**EEM:** 1.1  
**Scenario:** HRC  
**Calculated By:** RM1  
**Reviewed By:** DTA

**Notes Formulas**

- A** Outdoor Air Tdb
- B** Intentionally left blank
- C** Outdoor Air Twb
- D** Baseline Steam Usage [INPUT] from meter data adjuted utilizing weather data
- E** Intentionally left blank
- F** D x [Heating Load Adjustment]
- G** F / [Heat Rejection Summer] [Heat Rejection Winter]
- H** [Heat Rejection Summer Curve] [Heat Rejection Winter Curve] X G
- I** (H - F) < Well Capacity
- J** F - H - I

**Formulas**

- K** % Loading Based on largest load (heating or cooling)
- L** Baseline Chilled Water Usage [INPUT] from meter data adjuted utilizing weather data
- M** Intentionally left blank
- N** = L
- O** [Cooling Cap. Summer Curve] [Cooling Cap. Winter Curve] x G x 12
- P** = O
- Q** (O - N) < Well Capacity
- R** N - P
- S** [Summer kW Curve] [Winter kW Curve] x G
- T** U V Pump KW x K^2.3

*(note this does not include the energy usage for the Secondary Chilled Water Pumps. It is assumed this is offsetting the existing chilled water pumps)*

FORMULA INDEX	A	B	C	D	E	F	G	H	I	J	K	L	M	N	O	P	Q	R	S	T	U	V
MAX	96.0		81.0	0.5	39.7	467.7	726.6	504.6	726.0	0.4	70.6	0.6	35.8	591.2	567.5	567.5	354.7	53.8	46.6	0.4	0.9	18.8
MIN	4.0		2.0	0.0	0.0	0.0	1.1	0.0	0.0	0.0	1.2	0.0	0.0	9.3	9.4	9.3	0.0	0.0	0.4	0.0	0.9	0.0
SUM	466,903		417,724	1,184	110,632	1,183,891	1,884,076	1,294,522	580,961	1	215,428	648	53,603	648,397	1,393,967	701,627	692,277	373	143,639	486	8,013	33,057
Time Stamp	Outside dry-bulb temp (F)	Not Used	Outside wet-bulb temp (F)	Baseline Steam & HW Usage (mmBtu)	Additional Proposed OA Heating Load (MBH)	Adjusted Baseline Heating Load (MBH)	Heat Pump Heating (MBH)	Heat Recovery Heating (MBH)	Heat Rejected to Geothermal Well (MBH)	Supp Heating from Hxers (MBH)	% Heat Pump Load	Baseline CHW (mmBTU)	Additional Proposed OA Cooling Load (MBH)	Adjusted Baseline CHW Load (MBH)	Heat Pump Cooling (MBH)	Heat Recovery Cooling (MBH)	Heat Absorbed from Geothermal Well (MBH)	Supp Cooling from CHW plant (MBH)	HP Electrical Load (kW)	HP Chilled Water Pumps (kW)	HP Hot Water Pumps (kW)	Geothermal Pumps (kW)
1/1/22 0:00	47.0		47.0	0.2	21.0	205.9	229.0	226.8	0.0	0.0	28.4	0.0	0.0	27.5	163.6	27.5	136.1	0.0	19.1	0.0	0.9	3.5
1/1/22 1:00	47.0		47.0	0.2	21.0	205.9	229.0	226.8	0.0	0.0	28.4	0.0	0.0	27.5	163.6	27.5	136.1	0.0	19.1	0.0	0.9	3.5
1/1/22 2:00	47.0		47.0	0.2	21.0	205.9	229.0	226.8	0.0	0.0	28.4	0.0	0.0	27.5	163.6	27.5	136.1	0.0	19.1	0.0	0.9	3.5
1/1/22 3:00	47.0		47.0	0.2	21.0	205.9	229.0	226.8	0.0	0.0	28.4	0.0	0.0	27.5	163.6	27.5	136.1	0.0	19.1	0.0	0.9	3.5
1/1/22 4:00	47.5		47.0	0.2	20.7	203.9	226.8	224.7	0.0	0.0	28.1	0.0	0.0	26.8	162.1	26.8	125.3	0.0	19.0	0.0	0.9	3.3
1/1/22 5:00	47.0		47.0	0.2	21.0	205.9	229.0	226.8	0.0	0.0	28.4	0.0	0.0	27.5	163.6	27.5	136.1	0.0	19.1	0.0	0.9	3.5
1/1/22 6:00	48.0		48.0	0.2	20.5	202.0	224.6	222.5	0.0	0.0	27.9	0.0	0.0	26.8	160.5	26.8	123.8	0.0	18.8	0.0	0.9	3.2
1/1/22 7:00	48.0		48.0	0.2	20.5	202.0	224.6	222.5	0.0	0.0	27.9	0.0	0.0	26.8	160.5	26.8	123.8	0.0	18.8	0.0	0.9	3.2
1/1/22 8:00	48.5		48.0	0.2	20.3	200.1	222.5	220.3	0.0	0.0	27.6	0.0	0.0	26.8	159.0	26.8	123.8	0.0	18.6	0.0	0.9	3.9
1/1/22 9:00	49.0		49.0	0.2	20.1	198.1	220.3	218.2	0.0	0.0	27.3	0.0	0.0	26.8	157.4	26.8	123.8	0.0	18.4	0.0	0.9	3.8
1/1/22 10:00	50.0		50.0	0.2	19.6	194.2	216.0	213.9	0.0	0.0	26.8	0.0	0.0	26.8	154.3	26.8	123.8	0.0	18.1	0.0	0.9	3.8
1/1/22 11:00	51.0		50.0	0.2	19.2	190.3	211.6	209.5	0.0	0.0	26.2	0.0	0.0	26.8	151.2	26.8	123.8	0.0	17.7	0.0	0.9	3.7
1/1/22 12:00	51.0		50.0	0.2	19.2	190.3	211.6	209.5	0.0	0.0	26.2	0.0	0.0	26.8	151.2	26.8	123.8	0.0	17.7	0.0	0.9	3.7
1/1/22 13:00	52.0		51.5	0.2	18.8	186.5	207.3	205.2	0.0	0.0	25.7	0.0	0.0	26.8	148.1	26.8	123.8	0.0	17.4	0.0	0.9	3.6
1/1/22 14:00	53.5		52.5	0.2	18.1	180.6	200.7	198.7	0.0	0.0	24.9	0.0	0.0	26.8	143.4	26.8	123.8	0.0	16.8	0.0	0.9	3.5
1/1/22 15:00	52.0		51.3	0.2	18.8	186.5	207.3	205.2	0.0	0.0	25.7	0.0	0.0	26.8	148.1	26.8	123.8	0.0	17.4	0.0	0.9	3.6
1/1/22 16:00	52.0		51.2	0.2	18.8	186.5	207.3	205.2	0.0	0.0	25.7	0.0	0.0	26.8	148.1	26.8	123.8	0.0	17.4	0.0	0.9	3.6
1/1/22 17:00	52.0		51.3	0.2	18.8	186.5	207.3	205.2	0.0	0.0	25.7	0.0	0.0	26.8	148.1	26.8	123.8	0.0	17.4	0.0	0.9	3.6
1/1/22 18:00	52.0		51.0	0.2	18.8	186.5	207.3	205.2	0.0	0.0	25.7	0.0	0.0	26.8	148.1	26.8	123.8	0.0	17.4	0.0	0.9	3.6
1/1/22 19:00	51.5		50.5	0.2	19.0	188.4	209.4	207.4	0.0	0.0	26.0	0.0	0.0	26.8	149.6	26.8	123.8	0.0	17.5	0.0	0.9	2.9
1/1/22 20:00	51.5		50.5	0.2	19.0	188.4	209.4	207.4	0.0	0.0	26.0	0.0	0.0	26.8	149.6	26.8	123.8	0.0	17.5	0.0	0.9	2.9
1/1/22 21:00	51.5		50.5	0.2	19.0	188.4	209.4	207.4	0.0	0.0	26.0	0.0	0.0	26.8	149.6	26.8	123.8	0.0	17.5	0.0	0.9	2.9
1/1/22 22:00	51.0		50.0	0.2	19.2	190.3	211.6	209.5	0.0	0.0	26.2	0.0	0.0	26.8	151.2	26.8	123.8	0.0	17.7	0.0	0.9	3.0
1/1/22 23:00	51.5		50.5	0.2	19.0	188.4	209.4	207.4	0.0	0.0	26.0	0.0	0.0	26.8	149.6	26.8	123.8	0.0	17.5	0.0	0.9	2.9
1/2/22 0:00	51.5		50.0	0.2	19.0	188.4	209.4	207.4	0.0	0.0	26.0	0.0	0.0	26.8	149.6	26.8	123.8	0.0	17.5	0.0	0.9	3.6
1/2/22 1:00	50.0		50.0	0.2	19.6	194.2	216.0	213.9	0.0	0.0	26.8	0.0	0.0	26.8	154.3	26.8	123.8	0.0	18.1	0.0	0.9	3.8
1/2/22 2:00	51.5		50.5	0.2	19.0	188.4	209.4	207.4	0.0	0.0	26.0	0.0	0.0	26.8	149.6	26.8	123.8	0.0	17.5	0.0	0.9	3.6
1/2/22 3:00	51.5		50.5	0.2	19.0	188.4	209.4	207.4	0.0	0.0	26.0	0.0	0.0	26.8	149.6	26.8	123.8	0.0	17.5	0.0	0.9	3.6
1/2/22 4:00	50.0		49.0	0.2	19.6	194.2	216.0	213.9	0.0	0.0	26.8	0.0	0.0	26.8	154.3	26.8	123.8	0.0	18.1	0.0	0.9	3.8
1/2/22 5:00	51.0		50.0	0.2	19.2	190.3	211.6	209.5	0.0	0.0	26.2	0.0	0.0	26.8	151.2	26.8	123.8	0.0	17.7	0.0	0.9	3.7
1/2/22 6:00	50.0		49.0	0.2	19.6	194.2	216.0	213.9	0.0	0.0	26.8	0.0	0.0	26.8	154.3	26.8	123.8	0.0	18.1	0.0	0.9	3.8
1/2/22 7:00	50.0		49.0	0.2	19.6	194.2	216.0	213.9	0.0	0.0	26.8	0.0	0.0	26.8	154.3	26.8	123.8	0.0	18.1	0.0	0.9	3.8
1/2/22 8:00	51.0		50.0	0.2	19.2	190.3	211.6	209.5	0.0	0.0	26.2	0.0	0.0	26.8	151.2	26.8	123.8	0.0	17.7	0.0	0.9	3.7
1/2/22 9:00	51.0		50.0	0.2	19.2	190.3	211.6	209.5	0.0	0.0	26.2	0.0	0.0	26.8	151.2	26.8	123.8	0.0	17.7	0.0	0.9	3.7
1/2/22 10:00	52.0		51.0	0.2	18.8	186.5	207.3	205.2	0.0	0.0	25.7	0.0	0.0	26.8	148.1	26.8	123.8	0.0	17.4	0.0	0.9	3.6
1/2/22 11:00	52.0		51.5	0.2	18.8	186.5	207.3	205.2	0.0	0.0	25.7	0.0	0.0	26.8	148.1	26.8	123.8	0.0	17.4	0.0	0.9	3.6
1/2/22 12:00	50.0		49.0	0.2	19.6	194.23	215.96	213.9	0.00	0.00	26.8	0.01	0.00	26.8	154.3	26.8	123.8	0.00	18.1	0.0	0.9	3.8



**Project Name:** Hastings on Hudson Village Geothermal Heat Pump Study  
**Building:** Library  
**Date:** 7/11/2023  
**EEM:** 1.2  
**Calculated By:** RM1  
**Reviewed By:** DTA

**Summary of Existing System**

Low Temp Hot Water AHUs & Baseboard Radiators for Heating & CHW Cooling.

**Summary of Proposed System**

HW/CHW Heating and Cooling from Air Source Heat Recovery Heat Pumps.

**Measured Data**

Utility Data for Heating & Cooling Loads

**Data Limitations**

No submeters present to breakdown exact energy end uses, ASHRAE standards and previous project experience were used to disaggregate utilities.

**Conversions**

LP STM Enthalpy	1194 Btu/lb
Boilers Eff.	79%
System losses	2.5%

**Summary of Existing Systems Used for Calculation**

Existing System Summary			
Steam Utility Data	0 mmBTU	<b>A</b>	
Steam Utility Data	657 mmBTU	<b>B</b>	
Anticipated ECM HW Savings	0 mmBTU	<b>C</b>	
<b>Adjusted Baseline HW Use</b>	<b>657 mmBTU</b>	<b>D=B-C</b>	
CHW Utility Data	0 mmBTU	<b>A</b>	
CHW Utility Data	383 mmBTU	<b>B</b>	
Anticipated ECM CHW Savings	0 mmBTU	<b>C</b>	
<b>Adjusted Baseline CHW Use</b>	<b>383 mmBTU</b>	<b>D=B-C</b>	

**Proposed System Summary**

Heat Pump Cooling	349 mmBTU
Supplemental Cooling	34 mmBTU
Heat Pump Heating	657 mmBTU
Supplemental Heating	0 mmBTU
Pump Savings	1,676 kWh
Heat Pump Electrical Savings	-99,633 kWh

**Energy Benefits**

**Basecase Savings Summary**

CHW Savings	349 mmBtu
Electrical Savings	-97,957 kWh
Heating Savings	657 mmBTU

**Total Savings 672 mmBTU**

**Chilled Water & Steam Savings Summary**

Fre Cooling Tons	1,183 Ton-Hrs
Electric Chiller Tons	27,869 Ton-Hrs
Steam Chiller Tons	0 Tons
<b>Total Offset Tons</b>	<b>29,052 Ton-Hrs</b>
Steam Savings Heating (Heat Pump)	551 klbs/Year
<b>Steam Savings Total</b>	<b>551 klbs/Year</b>

**Utility Savings Summary**

Chiller Electric Savings	32,125 kWh
Net Electric Savings	-65,831 kWh
Net Electric Savings	-225 mmBTU
Natural Gas	853 mmBTU
<b>Total Savings</b>	<b>629 mmBTU</b>
Current Natural Gas Usage	853 mmBTU
Proposed Natural Gas Usage	0 mmBTU
Reduction in Fossil Fuel Usage	100.0%

\*\*\*\* CONFIDENTIAL AND PROPRIETARY \*\*\*  
 Copyright © 2023 Wendel Energy Services, LLC. All Rights Reserved."



Project Name: Hastings on Hudson Village Geothermal Heat Pump Study  
 Building: Library  
 Date: 7/11/2023  
 EEM: 1.2  
 Scenario: HRC - Air Source  
 Calculated By: RM1  
 Reviewed By: DTA

\*\*\*\* CONFIDENTIAL AND PROPRIETARY \*\*\*\*  
 Copyright © 2023 Wendel Energy Services, LLC. All Rights Reserved.™

Existing Energy Summary	
Utility Baseline CHW Use	383 mmBTU
Utility Baseline HW Use	657 mmBTU
Adjusted Baseline CHW Use	383 mmBTU
Adjusted Baseline HW Use	657 mmBTU
Baseline Pump Usage	2,302 kWh
Proposed Energy Summary	
Cooling Savings	349 mmBTU
Supplemental Cooling	34 mmBTU
Heating Savings	657 mmBTU
Supplemental Heating	0 mmBTU
HRC Pump Savings	1,676 kWh
HRC Electrical Savings	-99,633 kWh

Heat Recovery Chiller Performance Data				
	% Load	Cooling Cap.	Input Power	Heat
Summer	25.00	10.10	19.07	186.36
	50.00	20.20	38.14	372.7
	75.00	30.30	57.21	559.1
	100.00	40.40	76.31	745.4
Winter	25.00	10.10	19.07	186.36
	50.00	20.20	38.14	372.7
	75.00	30.30	57.21	559.1
	100.00	40.40	76.31	745.4

System Enable Setpoints			
HP Enable Temp	-20	deg F	
HW Enable Temp	-20	deg F	
Month Start	January	0	
Month End	December	12	
Ex. Chiller Eff.	1.14	kW/ton	
Load Safety Factor	100%		

Pump Savings

Heat Pump Elk



Summer to Winter Switch:	65
% Reference Performance	100%
# of Units	10
Tonnage Per Unit	1.0

Baseline Load Simulation & Reset Schedule			
OAT	HWST (°F)	CHWST (°F)	
0	180	55	
10	180	55	
20	180	55	
30	180	55	
40	180	55	
50	180	55	
60	180	55	
65	180	55	
70	180	55	
80	180	55	
90	180	55	
	X= 80.00	Y= 180.00	

Heat Pump / Geothermal Information			
Heat Pump Type	Standard		
Operation	Hybrid		
Geothermal Conductivity	3.0	ton/well	
Geothermal Wells	0	wells	
Total Capacity	0	Tons	
Total Capacity	0	MBH	
Heat Rejection Rate	1.21	btu/btu	
Heat Absorption Rate	0.674	btu/btu	

Heat Recovery Chiller Pump Information					
Pump Label	CHW Pumps Libr	CHW Pumps VH	HW Pumps VH	HW Pumps Libr	Geo Pumps
Motor HP	0.75	0	0	1.5	0
Motor Eff	82%	86%	86%	86%	89%
Pump GPM	48.48	#DIV/0!	#DIV/0!	37.27	#DIV/0!
Pump Eff	63.3%	77.4%	66.3%	61.0%	60.2%
BHP	0.62	0.00	0.00	0.69	#DIV/0!
Ft. Hd.	32	0	0	45	75
QTY	2	0	0	2	0
kW	1.1	0.0	0.0	1.2	#DIV/0!
Control Type	VV	VV	VV	VV	VV
Affinity Law Adj.	2.3	2.3	2.3	2.3	2.3

Central Plant Operations   CHW Eff.   STM to NG Eff.	
Boilers Eff.	79.0%
Electric Chiller Eff.	1.14 kW/Ton
Steam Chiller Eff.	N/A lbs/Ton
Free Cooling Eff.	0.30 kW/Ton
Free Cooling Enable	34 deg F (WB)
Free Cooling Capacity	1 tons
% CHW from STM	0%

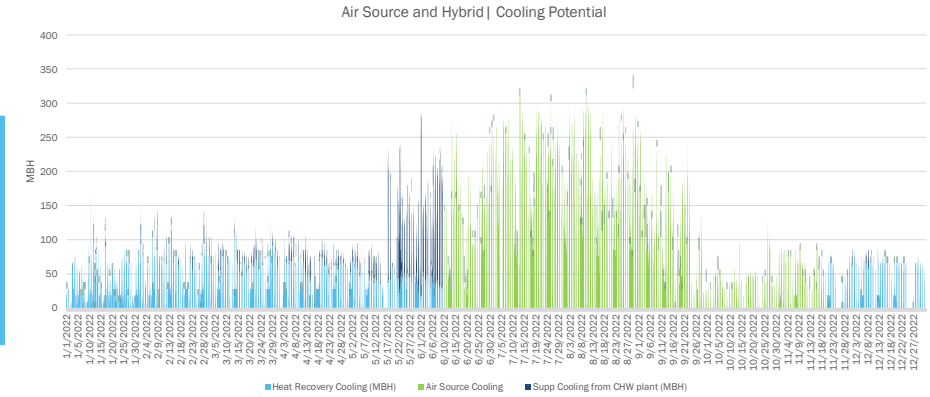
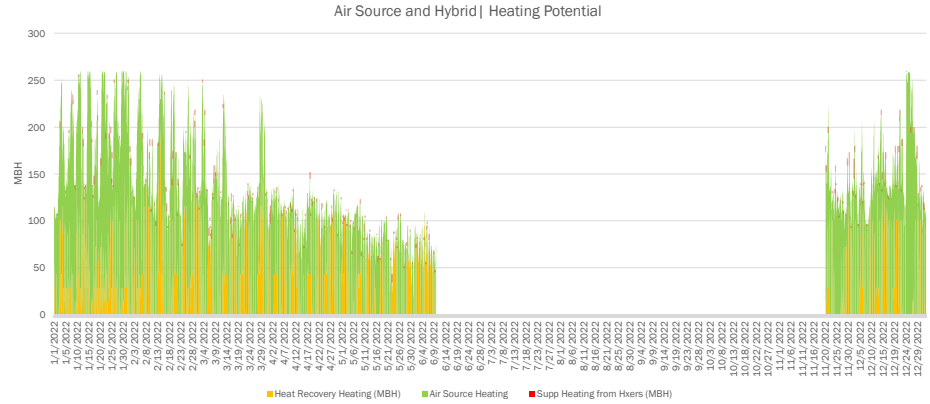





**Project Name:** Hastings on Hudson Village Geothermal Heat  
**Building:** Library  
**Date:** 7/11/2023  
**EEM:** 1.2  
**Scenario:** HRC - Air Source  
**Calculated By:** RM1  
**Reviewed By:** DTA

**Notes/Formulas**

- A** Outdoor Air Tdb
- B** Intentionally left blank
- C** Outdoor Air Twb
- D** Baseline Steam Usage [INPUT] from meter data adjuted utilizing weather data
- E** Intentionally left blank
- F** D x [Heating Load Adjustment]
- G** F / [Heat Rejection Summer] [Heat Rejection Winter]
- H** [Heat Rejection Summer Curve] [Heat Rejection Winter Curve] X G
- I** (H - F) < Well Capacity
- J** F - H - I

**Formulas**

- K** % Loading Based on largest load (heating or cooling)
- L** Baseline Chilled Water Usage [INPUT] from meter data adjuted utilizing weather data
- M** Intentionally left blank
- N** = L
- O** [Cooling Cap. Summer Curve] [Cooling Cap. Winter Curve] x G x 12
- P** = O
- Q** (O - N) < Well Capacity
- R** N - P
- S** [Summer kW Curve] [Winter kW Curve] x G
- TUV** Pump KW x K^\*2.3

*(note this does not include the energy usage for the Secondary Chilled Water Pumps. It is assumed this is offsetting the existing chilled water pumps)*

FORMULA INDEX	A	B	C	D	E	F	G	H	I	J	K	L	M	N	O	P	Q	R	S	T	U	V
MAX	96.0		81.0	0.3	0.0	259.7	259.7	250.9	0.0	0.0	68.4	0.3	0.0	340.7	340.7	163.1	0.0	272.6	45.0	0.3	0.5	0.0
MIN	4.0		2.0	0.0	0.0	0.0	0.0	0.0	0.0	0.0	0.0	0.0	0.0	0.0	0.0	0.0	0.0	0.0	0.0	0.0	0.0	0.0
SUM	466,903		417,724	657	0	657,312	657,312	182,241	0	0	179,872	383	0	382,815	348,620	118,523	0	34,195	99,633	96	529	0
Time Stamp	Outside dry-bulb temp (F)	Not Used	Outside wet-bulb temp (F)	Baseline Steam & HW Usage (mmBtu)	Additional Proposed OA Heating Load (MBH)	Adjusted Baseline Heating Load (MBH)	Heat Pump Heating (MBH)	Heat Recovery Heating (MBH)	Heat Rejected to Geothermal Well (MBH)	Supp Heating from Hxers (MBH)	% Heat Pump Load	Baseline CHW (mmBTU)	Additional Proposed OA Cooling Load (MBH)	Adjusted Baseline CHW Load (MBH)	Heat Pump Cooling (MBH)	Heat Recovery Cooling (MBH)	Heat Absorbed from Geothermal Well (MBH)	Supp Cooling from CHW plant (MBH)	HP Electrical Load (kW)	HP Chilled Water Pumps (kW)	HP Hot Water Pumps (kW)	Geothermal Pumps (kW)
1/1/22 0:00	47.0		47.0	0.1	0.0	114.3	114.3	28.5	0.0	0.0	26.4	0.0	0.0	18.6	18.6	18.6	0.0	0.0	12.8	0.0	0.1	0.0
1/1/22 1:00	47.0		47.0	0.1	0.0	114.3	114.3	28.5	0.0	0.0	26.4	0.0	0.0	18.6	18.6	18.6	0.0	0.0	12.8	0.0	0.1	0.0
1/1/22 2:00	47.0		47.0	0.1	0.0	114.3	114.3	28.5	0.0	0.0	26.4	0.0	0.0	18.6	18.6	18.6	0.0	0.0	12.8	0.0	0.1	0.0
1/1/22 3:00	47.0		47.0	0.1	0.0	114.3	114.3	28.5	0.0	0.0	26.4	0.0	0.0	18.6	18.6	18.6	0.0	0.0	12.8	0.0	0.1	0.0
1/1/22 4:00	47.5		47.0	0.1	0.0	113.2	113.2	43.1	0.0	0.0	24.3	0.0	0.0	28.0	28.0	28.0	0.0	0.0	12.4	0.0	0.0	0.0
1/1/22 5:00	47.0		47.0	0.1	0.0	114.3	114.3	57.7	0.0	0.0	22.7	0.0	0.0	37.5	37.5	37.5	0.0	0.0	12.4	0.0	0.0	0.0
1/1/22 6:00	48.0		48.0	0.1	0.0	112.1	112.1	43.1	0.0	0.0	24.0	0.0	0.0	28.0	28.0	28.0	0.0	0.0	12.3	0.0	0.0	0.0
1/1/22 7:00	48.0		48.0	0.1	0.0	112.1	112.1	0.0	0.0	0.0	29.6	0.0	0.0	0.0	0.0	0.0	0.0	0.0	12.8	0.0	0.1	0.0
1/1/22 8:00	48.5		48.0	0.1	0.0	111.1	111.1	0.0	0.0	0.0	29.3	0.0	0.0	0.0	0.0	0.0	0.0	0.0	12.6	0.0	0.1	0.0
1/1/22 9:00	49.0		49.0	0.1	0.0	110.0	110.0	0.0	0.0	0.0	29.0	0.0	0.0	0.0	0.0	0.0	0.0	0.0	12.4	0.0	0.1	0.0
1/1/22 10:00	50.0		50.0	0.1	0.0	107.8	107.8	0.0	0.0	0.0	28.4	0.0	0.0	0.0	0.0	0.0	0.0	0.0	12.1	0.0	0.1	0.0
1/1/22 11:00	51.0		50.0	0.1	0.0	105.7	105.7	0.0	0.0	0.0	27.9	0.0	0.0	0.0	0.0	0.0	0.0	0.0	11.7	0.0	0.1	0.0
1/1/22 12:00	51.0		50.0	0.1	0.0	105.7	105.7	0.0	0.0	0.0	27.9	0.0	0.0	0.0	0.0	0.0	0.0	0.0	11.7	0.0	0.1	0.0
1/1/22 13:00	52.0		51.5	0.1	0.0	103.5	103.5	0.0	0.0	0.0	27.3	0.0	0.0	0.0	0.0	0.0	0.0	0.0	11.3	0.0	0.1	0.0
1/1/22 14:00	53.5		52.5	0.1	0.0	100.3	100.3	0.0	0.0	0.0	26.4	0.0	0.0	0.0	0.0	0.0	0.0	0.0	10.8	0.0	0.1	0.0
1/1/22 15:00	52.0		51.3	0.1	0.0	103.5	103.5	0.0	0.0	0.0	27.3	0.0	0.0	0.0	0.0	0.0	0.0	0.0	11.3	0.0	0.1	0.0
1/1/22 16:00	52.0		51.2	0.1	0.0	103.5	103.5	0.0	0.0	0.0	27.3	0.0	0.0	0.0	0.0	0.0	0.0	0.0	11.3	0.0	0.1	0.0
1/1/22 17:00	52.0		51.3	0.1	0.0	103.5	103.5	0.0	0.0	0.0	27.3	0.0	0.0	0.0	0.0	0.0	0.0	0.0	11.3	0.0	0.1	0.0
1/1/22 18:00	52.0		51.0	0.1	0.0	103.5	103.5	0.0	0.0	0.0	27.3	0.0	0.0	0.0	0.0	0.0	0.0	0.0	11.3	0.0	0.1	0.0
1/1/22 19:00	51.5		50.5	0.1	0.0	104.6	104.6	43.1	0.0	0.0	22.0	0.0	0.0	28.0	28.0	28.0	0.0	0.0	11.2	0.0	0.0	0.0
1/1/22 20:00	51.5		50.5	0.1	0.0	104.6	104.6	43.1	0.0	0.0	22.0	0.0	0.0	28.0	28.0	28.0	0.0	0.0	11.2	0.0	0.0	0.0
1/1/22 21:00	51.5		50.5	0.1	0.0	104.6	104.6	43.1	0.0	0.0	22.0	0.0	0.0	28.0	28.0	28.0	0.0	0.0	11.2	0.0	0.0	0.0
1/1/22 22:00	51.0		50.0	0.1	0.0	105.7	105.7	43.1	0.0	0.0	22.3	0.0	0.0	28.0	28.0	28.0	0.0	0.0	11.3	0.0	0.0	0.0
1/1/22 23:00	51.5		50.5	0.1	0.0	104.6	104.6	43.1	0.0	0.0	22.0	0.0	0.0	28.0	28.0	28.0	0.0	0.0	11.2	0.0	0.0	0.0
1/2/22 0:00	51.5		50.0	0.1	0.0	104.6	104.6	0.0	0.0	0.0	27.6	0.0	0.0	0.0	0.0	0.0	0.0	0.0	11.5	0.0	0.1	0.0
1/2/22 1:00	50.0		50.0	0.1	0.0	107.8	107.8	0.0	0.0	0.0	28.4	0.0	0.0	0.0	0.0	0.0	0.0	0.0	12.1	0.0	0.1	0.0
1/2/22 2:00	51.5		50.5	0.1	0.0	104.6	104.6	0.0	0.0	0.0	27.6	0.0	0.0	0.0	0.0	0.0	0.0	0.0	11.5	0.0	0.1	0.0
1/2/22 3:00	51.5		50.5	0.1	0.0	104.6	104.6	0.0	0.0	0.0	27.6	0.0	0.0	0.0	0.0	0.0	0.0	0.0	11.5	0.0	0.1	0.0
1/2/22 4:00	50.0		49.0	0.1	0.0	107.8	107.8	0.0	0.0	0.0	28.4	0.0	0.0	0.0	0.0	0.0	0.0	0.0	12.1	0.0	0.1	0.0
1/2/22 5:00	51.0		50.0	0.1	0.0	105.7	105.7	0.0	0.0	0.0	27.9	0.0	0.0	0.0	0.0	0.0	0.0	0.0	11.7	0.0	0.1	0.0
1/2/22 6:00	50.0		49.0	0.1	0.0	107.8	107.8	0.0	0.0	0.0	28.4	0.0	0.0	0.0	0.0	0.0	0.0	0.0	12.1	0.0	0.1	0.0
1/2/22 7:00	50.0		49.0	0.1	0.0	107.8	107.8	0.0	0.0	0.0	28.4	0.0	0.0	0.0	0.0	0.0	0.0	0.0	12.1	0.0	0.1	0.0
1/2/22 8:00	51.0		50.0	0.1	0.0	105.7	105.7	0.0	0.0	0.0	27.9	0.0	0.0	0.0	0.0	0.0	0.0	0.0	11.7	0.0	0.1	0.0
1/2/22 9:00	51.0		50.0	0.1	0.0	105.7	105.7	0.0	0.0	0.0	27.9	0.0	0.0	0.0	0.0	0.0	0.0	0.0	11.7	0.0	0.1	0.0
1/2/22 10:00	52.0		51.0	0.1	0.0	103.5	103.5	0.0	0.0	0.0	27.3	0.0	0.0	0.0	0.0	0.0	0.0	0.0	11.3	0.0	0.1	0.0
1/2/22 11:00	52.0		51.5	0.1	0.0	103.5	103.5	0.0	0.0	0.0	27.3	0.0	0.0	0.0	0.0	0.0	0.0	0.0	11.3	0.0	0.1	0.0
1/2/22 12:00	50.0		49.0	0.1	0.0	107.84	107.84	0.0	0.00	0.00	28.4	0.00	0.00	0.00	0.00	0.00	0.00	0.00	12.1	0.0	0.1	0.0

MEASURE SUMMARY | Air Source Heat Pump



Project Name: Hastings on Hudson Village Geothermal Heat Pump Study  
 Building: Village Hall  
 Date: 7/11/2023  
 EEM 1.2  
 Calculated By: RM1  
 Reviewed By: DTA

**Summary of Existing System**

Steam Perimeter Radiation & Limited DX Cooling

**Summary of Proposed System**

Heating and Cooling from Vertical Stack FCUs with external Condensing Units.

**Measured Data**

Utility Data for Heating & Cooling Loads

**Data Limitations**

No submeters present to breakdown exact energy end uses, ASHRAE standards and previous project experinece were used to disaggregate utilities.

**Conversions**

LP STM Enthalpy	1194 Btu/lb
Boilers Eff.	79%
System losses	2.50%

**Summary of Existing Systems Used for Calculation**

Existing System Summary			
Steam Utility Data	0 mmBTU	<b>A</b>	
Steam Utility Data	527 mmBTU	<b>B</b>	
Anticipated ECM HW Savings	0 mmBTU	<b>C</b>	
<b>Adjusted Baseline HW Use</b>	<b>527 mmBTU</b>	<b>D=B-C</b>	
Cooling Utility Data	0 mmBTU	<b>A</b>	
Cooling Utility Data	257 mmBTU	<b>B</b>	
Anticipated ECM Cooling Savings	0 mmBTU	<b>C</b>	
<b>Adjusted Baseline CHW Use</b>	<b>257 mmBTU</b>	<b>D=B-C</b>	

**Proposed System Summary**

Heat Pump Cooling	125 mmBTU
Winter Cooling	132 mmBTU
Heat Pump Heating	527 mmBTU
Supplemental Heating	0 mmBTU
Pump Savings	0 kWh
Heat Pump Electrical Savings	-85,666 kWh
Fan Usage	-1,534 kWh

**Energy Benefits**

**Basecase Savings Summary**

Cooling Savings	125 mmBtu
Cooling Savings	-87,200 kWh
Heating Savings	527 mmBTU

**Total Savings 354 mmBTU**

**Chilled Water & Steam Savings Summary**

Fre Cooling Tons	86 Ton-Hrs
Electric Cooling Tons	10,360 Ton-Hrs
Steam Chiller Tons	0 Tons
<b>Total Offset Tons</b>	<b>10,446 Ton-Hrs</b>
Steam Savings Heating (Heat Pump)	441 klbs/Year
<b>Steam Savings Total</b>	<b>441 klbs/Year</b>

**Utility Savings Summary**

Cooling Electric Savings	12,882 kWh
Net Electric Savings	-74,317 kWh
Net Electric Savings	-254 mmBTU
Natural Gas	684 mmBTU
<b>Total Savings</b>	<b>430 mmBTU</b>
Current Natural Gas Usage	684 mmBTU
Proposed Natural Gas Usage	0 mmBTU
Reduction in Fossil Fuel Usage	100.0%

\*\*\*\* CONFIDENTIAL AND PROPRIETARY \*\*\*\*  
 Copyright © 2023 Wendel Energy Services, LLC. All Rights Reserved."



**Project Name:** Hastings on Hudson Village Geothermal Heat Pump Study  
**Building:** Village Hall  
**Date:** 7/11/2023  
**EEM:** 1.2  
**Scenario:** HRC - Air Source  
**Calculated By:** RM1  
**Reviewed By:** DTA

\*\*\*\*\* CONFIDENTIAL AND PROPRIETARY \*\*\*\*\*  
 Copyright © 2023 Wendel Energy Services, LLC. All Rights Reserved.

Existing Energy Summary	
Utility Baseline Cooling Use	257 mmBTU
Utility Baseline Steam Use	527 mmBTU
Adjusted Baseline Cooling Use	257 mmBTU
Adjusted Baseline Steam Use	527 mmBTU
Baseline Pump Usage	0 kWh
Proposed Energy Summary	
Cooling Savings	125 mmBTU
Winter Cooling	132 mmBTU
Heating Savings	527 mmBTU
Supplemental Heating	0 mmBTU
HRC Pump Savings	0 kWh
HRC Electrical Savings	-85,666 kWh

Heat Pump Performance Data				
	Outside Air	Input Power	COP	Heat Pump
Summer	102.00	36.63	3.18	397.21
	91.00	34.21	3.51	410.1
	81.00	31.90	3.93	427.6
	68.00	29.37	4.53	454.0
Winter	50.00	31.46	3.55	380.60
	32.00	46.09	2.42	380.6
	17.00	62.15	1.79	380.6
	5.00	72.16	1.55	380.6

System Enable Setpoints			
HP Enable Temp	-20	deg F	
HW Enable Temp	-20	deg F	
Month Start	January	0	
Month End	December	12	
Ex. Chiller Eff.	1.24		kW/ton
Load Safety Factor	100%		

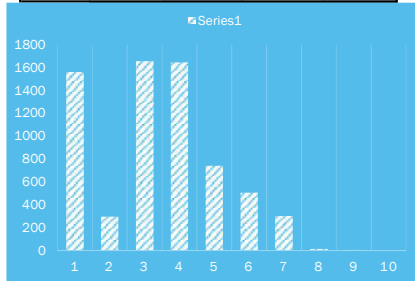

Summer to Winter Switch:	65
% Reference Performance	100%
# of Units	11.00
MBH Per Unit	3

Baseline Load Simulation & Reset Schedule			
OAT	HWST (°F)	CHWST (°F)	
0	180	55	
10	180	55	
20	180	55	
30	180	55	
40	180	55	
50	180	55	
60	180	55	
70	180	55	
80	180	55	
90	180	55	
	0	0	180
	X=	80.00	Y= 180.00

Heat Pump / Geothermal Information		
Heat Pump Type	Standard	
Operation	Air Source	
Geothermal Conductivity	3.0	ton/well
Geothermal Wells	0	wells
Total Capacity	0	Tons
Total Capacity	0	MBH
Heat Rejection Rate	1.21	btu/btu
Heat Absorption Rate	0.674	btu/btu

Heat Recovery Chiller Pump Information					
Pump Label	CHW Pumps Libr	CHW Pumps VH	HW Pumps VH	HW Pumps Libr	Geo Pumps
Motor HP	0	0	0	0	0
Motor Eff	82%	86%	86%	86%	89%
Pump GPM	#DIV/0!	#DIV/0!	#DIV/0!	#DIV/0!	#DIV/0!
Pump Eff	63.3%	77.4%	66.3%	61.0%	60.2%
BHP	0.00	0.00	0.00	0.00	#DIV/0!
Ft. Hd.	0	0	0	0	75
QTY	0	0	0	0	0
kW	0.0	0.0	0.0	0.0	#DIV/0!
Control Type	W	W	W	W	W
Affinity Law Adj.	2.3	2.3	2.3	2.3	2.3

Central Plant Operations   CHW Eff.   STM to NG Eff.	
Boilers Eff.	79.0%
Electric Chiller Eff.	1.24 kW/Ton
Steam Chiller Eff.	N/A lbs/Ton
Free Cooling Eff.	0.30 kW/Ton
Free Cooling Enable	34 deg F (WB)
Free Cooling Capacity	1 tons
% CHW from STM	0%

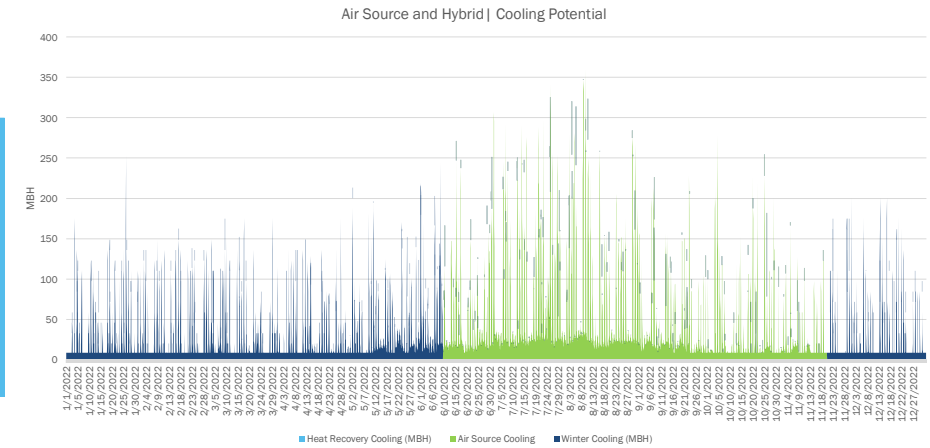
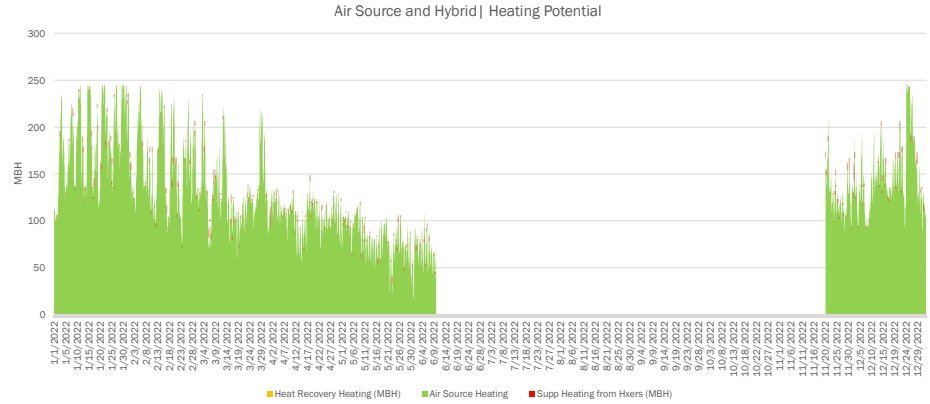



**Project Name:** Hastings on Hudson Village Geothermal Heat  
**Building:** Village Hall  
**Date:** 7/11/2023  
**EEM:** 1.2  
**Scenario:** HRC - Air Source  
**Calculated By:** RM1  
**Reviewed By:** DTA

**Notes Formulas**

- A** Outdoor Air Tdb
- B** Intentionally left blank
- C** Outdoor Air Twb
- D** Baseline Steam Usage [INPUT] from meter data adjuted utilizing weather data
- E** Intentionally left blank
- F** D x [Heating Load Adjustment]
- Q** F / [Heat Rejection Summer] [Heat Rejection Winter]
- H** [Heat Rejection Summer Curve] [Heat Rejection Winter Curve] X G
- I** ( H - F ) < Well Capacity
- J** F - H - I

**Formulas**

- K** % Loading Based on largest load (heating or cooling)
- L** Baseline Chilled Water Usage [INPUT] from meter data adjuted utilizing weather data
- M** Intentionally left blank
- N** = L
- O** [Cooling Cap. Summer Curve] [Cooling Cap. Winter Curve] x G x 12
- P** = 0
- Q** ( O - N ) < Well Capacity
- R** N - P
- S** [Summer kW Curve] [Winter kW Curve] x G
- T U V** Pump KW x K^\*2.3

*(note this does not include the energy usage for the Secondary Chilled Water Pumps. It is assumed this is offsetting the existing chilled water pumps)*

FORMULA INDEX	A	B	C	D	E	F	G	H	I	J	K	L	M	N	O	P	Q	R	S	T	U	V
MAX	96.0		81.0	0.2	39.7	208.0	245.0	0.0	0.0	0.0	87.3	0.3	35.8	329.0	359.5	0.0	0.0	251.8	45.3	0.0	0.0	0.0
MIN	4.0		2.0	0.0	0.0	0.0	0.0	0.0	0.0	0.0	0.0	0.0	0.0	8.8	0.0	0.0	0.0	0.0	0.7	0.0	0.0	0.0
SUM	466.903		417.724	527	110.632	526.579	637.211	0	0	0	193.242	257	53.603	257.323	178.957	0	0	131.969	85.666	0	0	0
Time Stamp	Outside dry-bulb temp (F)	Not Used	Outside wet-bulb temp (F)	Baseline Steam & HW Usage (mmBtu)	Additional Proposed OA Heating Load (MBH)	Adjusted Baseline Heating Load (MBH)	Heat Pump Heating (MBH)	Heat Recovery Heating (MBH)	Heat Rejected to Geothermal Well (MBH)	Supp Heating from Hxers (MBH)	% Heat Pump Load	Baseline CHW (mmBTU)	Additional Proposed OA Cooling Load (MBH)	Adjusted Baseline CHW Load (MBH)	Heat Pump Cooling (MBH)	Heat Recovery Cooling (MBH)	Heat Absorbed from Geothermal Well (MBH)	Winter Cooling (MBH)	HP Electrical Load (kW)	HP Chilled Water Pumps (kW)	HP Hot Water Pumps (kW)	Geothermal Pumps (kW)
1/1/22 0:00	47.0		47.0	0.1	21.0	91.6	112.5	0.0	0.0	0.0	29.6	0.0	0.0	8.8	0.0	0.0	0.0	8.8	9.9	0.0	0.0	0.0
1/1/22 1:00	47.0		47.0	0.1	21.0	91.6	112.5	0.0	0.0	0.0	29.6	0.0	0.0	8.8	0.0	0.0	0.0	8.8	9.9	0.0	0.0	0.0
1/1/22 2:00	47.0		47.0	0.1	21.0	91.6	112.5	0.0	0.0	0.0	29.6	0.0	0.0	8.8	0.0	0.0	0.0	8.8	9.9	0.0	0.0	0.0
1/1/22 3:00	47.0		47.0	0.1	21.0	91.6	112.5	0.0	0.0	0.0	29.6	0.0	0.0	8.8	0.0	0.0	0.0	8.8	9.9	0.0	0.0	0.0
1/1/22 4:00	47.5		47.0	0.1	20.7	90.7	111.4	0.0	0.0	0.0	29.3	0.0	0.0	8.8	0.0	0.0	0.0	8.8	9.7	0.0	0.0	0.0
1/1/22 5:00	47.0		47.0	0.1	21.0	91.6	112.5	0.0	0.0	0.0	29.6	0.0	0.0	8.8	0.0	0.0	0.0	8.8	9.9	0.0	0.0	0.0
1/1/22 6:00	48.0		48.0	0.1	20.5	89.8	110.4	0.0	0.0	0.0	29.0	0.0	0.0	8.8	0.0	0.0	0.0	8.8	9.5	0.0	0.0	0.0
1/1/22 7:00	48.0		48.0	0.1	20.5	89.8	110.4	0.0	0.0	0.0	29.0	0.0	0.0	8.8	0.0	0.0	0.0	8.8	9.5	0.0	0.0	0.0
1/1/22 8:00	48.5		48.0	0.1	20.3	89.0	109.3	0.0	0.0	0.0	28.7	0.0	0.0	8.8	0.0	0.0	0.0	8.8	9.3	0.0	0.0	0.0
1/1/22 9:00	49.0		49.0	0.1	20.1	88.1	108.2	0.0	0.0	0.0	28.4	0.0	0.0	8.8	0.0	0.0	0.0	8.8	9.1	0.0	0.0	0.0
1/1/22 10:00	50.0		50.0	0.1	19.6	86.4	106.0	0.0	0.0	0.0	27.9	0.0	0.0	8.8	0.0	0.0	0.0	8.8	8.8	0.0	0.0	0.0
1/1/22 11:00	51.0		50.0	0.1	19.2	84.7	103.9	0.0	0.0	0.0	27.3	0.0	0.0	8.8	0.0	0.0	0.0	8.8	8.4	0.0	0.0	0.0
1/1/22 12:00	51.0		50.0	0.1	19.2	84.7	103.9	0.0	0.0	0.0	27.3	0.0	0.0	8.8	0.0	0.0	0.0	8.8	8.4	0.0	0.0	0.0
1/1/22 13:00	52.0		51.5	0.1	18.8	82.9	101.7	0.0	0.0	0.0	26.7	0.0	0.0	8.8	0.0	0.0	0.0	8.8	8.1	0.0	0.0	0.0
1/1/22 14:00	53.5		52.5	0.1	18.1	80.3	98.5	0.0	0.0	0.0	25.9	0.0	0.0	8.8	0.0	0.0	0.0	8.8	7.6	0.0	0.0	0.0
1/1/22 15:00	52.0		51.3	0.1	18.8	82.9	101.7	0.0	0.0	0.0	26.7	0.0	0.0	8.8	0.0	0.0	0.0	8.8	8.1	0.0	0.0	0.0
1/1/22 16:00	52.0		51.2	0.1	18.8	82.9	101.7	0.0	0.0	0.0	26.7	0.0	0.0	8.8	0.0	0.0	0.0	8.8	8.1	0.0	0.0	0.0
1/1/22 17:00	52.0		51.3	0.1	18.8	82.9	101.7	0.0	0.0	0.0	26.7	0.0	0.0	8.8	0.0	0.0	0.0	8.8	8.1	0.0	0.0	0.0
1/1/22 18:00	52.0		51.0	0.1	18.8	82.9	101.7	0.0	0.0	0.0	26.7	0.0	0.0	8.8	0.0	0.0	0.0	8.8	8.1	0.0	0.0	0.0
1/1/22 19:00	51.5		50.5	0.1	19.0	83.8	102.8	0.0	0.0	0.0	27.0	0.0	0.0	8.8	0.0	0.0	0.0	8.8	8.2	0.0	0.0	0.0
1/1/22 20:00	51.5		50.5	0.1	19.0	83.8	102.8	0.0	0.0	0.0	27.0	0.0	0.0	8.8	0.0	0.0	0.0	8.8	8.2	0.0	0.0	0.0
1/1/22 21:00	51.5		50.5	0.1	19.0	83.8	102.8	0.0	0.0	0.0	27.0	0.0	0.0	8.8	0.0	0.0	0.0	8.8	8.2	0.0	0.0	0.0
1/1/22 22:00	51.0		50.0	0.1	19.2	84.7	103.9	0.0	0.0	0.0	27.3	0.0	0.0	8.8	0.0	0.0	0.0	8.8	8.4	0.0	0.0	0.0
1/1/22 23:00	51.5		50.5	0.1	19.0	83.8	102.8	0.0	0.0	0.0	27.0	0.0	0.0	8.8	0.0	0.0	0.0	8.8	8.2	0.0	0.0	0.0
1/2/22 0:00	51.5		50.0	0.1	19.0	83.8	102.8	0.0	0.0	0.0	27.0	0.0	0.0	8.8	0.0	0.0	0.0	8.8	8.2	0.0	0.0	0.0
1/2/22 1:00	50.0		50.0	0.1	19.6	86.4	106.0	0.0	0.0	0.0	27.9	0.0	0.0	8.8	0.0	0.0	0.0	8.8	8.8	0.0	0.0	0.0
1/2/22 2:00	51.5		50.5	0.1	19.0	83.8	102.8	0.0	0.0	0.0	27.0	0.0	0.0	8.8	0.0	0.0	0.0	8.8	8.2	0.0	0.0	0.0
1/2/22 3:00	51.5		50.5	0.1	19.0	83.8	102.8	0.0	0.0	0.0	27.0	0.0	0.0	8.8	0.0	0.0	0.0	8.8	8.2	0.0	0.0	0.0
1/2/22 4:00	50.0		49.0	0.1	19.6	86.4	106.0	0.0	0.0	0.0	27.9	0.0	0.0	8.8	0.0	0.0	0.0	8.8	8.8	0.0	0.0	0.0
1/2/22 5:00	51.0		50.0	0.1	19.2	84.7	103.9	0.0	0.0	0.0	27.3	0.0	0.0	8.8	0.0	0.0	0.0	8.8	8.4	0.0	0.0	0.0
1/2/22 6:00	50.0		49.0	0.1	19.6	86.4	106.0	0.0	0.0	0.0	27.9	0.0	0.0	8.8	0.0	0.0	0.0	8.8	8.8	0.0	0.0	0.0
1/2/22 7:00	50.0		49.0	0.1	19.6	86.4	106.0	0.0	0.0	0.0	27.9	0.0	0.0	8.8	0.0	0.0	0.0	8.8	8.8	0.0	0.0	0.0
1/2/22 8:00	51.0		50.0	0.1	19.2	84.7	103.9	0.0	0.0	0.0	27.3	0.0	0.0	8.8	0.0	0.0	0.0	8.8	8.4	0.0	0.0	0.0
1/2/22 9:00	51.0		50.0	0.1	19.2	84.7	103.9	0.0	0.0	0.0	27.3	0.0	0.0	8.8	0.0	0.0	0.0	8.8	8.4	0.0	0.0	0.0
1/2/22 10:00	52.0		51.0	0.1	18.8	82.9	101.7	0.0	0.0	0.0	26.7	0.0	0.0	8.8	0.0	0.0	0.0	8.8	8.1	0.0	0.0	0.0
1/2/22 11:00	52.0		51.5	0.1	18.8	82.9	101.7	0.0	0.0	0.0	26.7	0.0	0.0	8.8	0.0	0.0	0.0	8.8	8.1	0.0	0.0	0.0
1/2/22 12:00	50.0		49.0	0.1	19.6	86.39	106.03	0.0	0.00	0.00	27.9	0.01	0.00	8.78	0.0	0.00	0.00	8.78	8.8	0.0	0.0	0.0



## Village of Hastings-on-Hudson GSHP Study Solar PV Summary 7/18/2023

(Yes (N)o (O)ption	Mounting Type	Proposed Array Name	Total Measure Cost (\$)	Array Size (kW)	Annual Production (kWh)	Annual O&M Savings (\$)	Annual Electrical Savings (\$)	Total Annual Savings (\$)
Y	Parking Canopy	Proposed Parking Canopy Solar	\$313,534	52	62,189	-\$518	\$9,403	\$8,885
Y	Roof Mount	Library Proposed Rooftop PV	\$377,257	125	149,656	-\$1,247	\$22,628	\$21,381
<b>PROGRAM TOTALS - Energy Project (EP)</b>			<b>\$690,791</b>	<b>177</b>	<b>211,844</b>	<b>-\$1,765</b>	<b>\$32,031</b>	<b>\$30,265</b>

**NOTES:**

- TOTAL MEASURE COST includes direct construction costs (subcontractor material and labor) and DOES include fees for services described below:  
Energy, Electrical and Mechanical engineering, Construction documents, Financing assistance services, Subcontractor coordination and administration



### Electrical Service Summary

BUILDING: Village Hall  
 SERVICE VOLTAGE: 208 V

Equipment	Rated Current	Rating Type	Equipment Voltage	QTY	ADDED CURRENT (AMPS) @ 208V
NEW 0.5 Ton WSHP Units	5	MCA	208	43	232
NEW 1.5 Ton WSHP Units	12	MCA	208	5	62
NEW Geo Water Loop Pumps (2)	31	FLA	208	2	62
Remove Window ACs	6	FLA	120	-11	-37
Remove PTAC	10	FLA	120	-1	-6
Remove PTAC	8	FLA	120	-1	-5
Remove Split AC	14	FLA	120	-3	-25
Remove Library HW Pumps	3	FLA	208	-2	-5
Added Capacity from EV Upgrade (400 Amps)	400	FLA	208	-1	-400
EV Chargers	250	FLA	208	1	250

**Current Electrical Capacity**

Total Added Amps 208V: 128

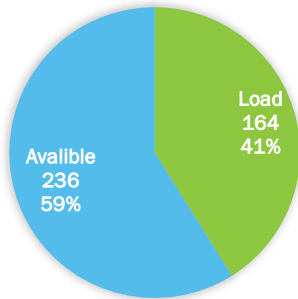

Electrical Service | Ampacity Summary | Project Impact

Total Capacity	Current Load	Cummulative Ampacity @ Building Voltage
400	164	293

Good

### Electrical Service Summary

BUILDING: Library  
 SERVICE VOLTAGE: 208 V

Equipment	Rated Current	Rating Type	Equipment Voltage	QTY	ADDED CURRENT (AMPS) @ 208V
Remove Air Cooled Chiller	184	MCA	208	-1	-184
10 Ton Heat Pump	54	MCA	208	4	216
NEW Library Hot Water Loop Pumps (2)	3	FLA	208	2	6
Remove Old Library CHW Loop Pumps	3	FLA	208	-2	-6
NEW Library Chilled Water Loop Pumps (2)	2	FLA	208	2	3

**Current Electrical Capacity**

Total Added Amps 208V: 35

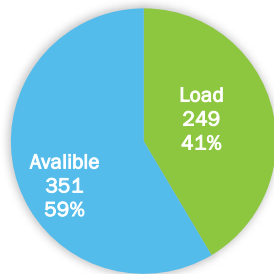

Electrical Service | Ampacity Summary | Project Impact

Total Capacity	Current Load	Cummulative Ampacity @ Building Voltage
600	249	284

Good

### Electrical Service Summary

BUILDING: Village Hall  
 SERVICE VOLTAGE: 208 V

Equipment	Rated Current	Rating Type	Equipment Voltage	QTY	ADDED CURRENT (AMPS) @ 208V
Condensing Units	36.5	MCA	208	11	402
Vertical Stack FCUs	0.36	FLA	208	22	8
Remove Window ACs	6	FLA	120	-11	-37
Remove PTAC	10	FLA	120	-1	-6
Remove PTAC	8	FLA	120	-1	-5
Remove Split AC	14	FLA	120	-3	-25
Remove Library HW Pumps	3	FLA	208	-2	-5
Added Capacity from EV Upgrade (400 Amps)	400	FLA	208	-1	-400
EV Chargers	250	FLA	208	1	250

**Current Electrical Capacity**

Total Added Amps 208V

182

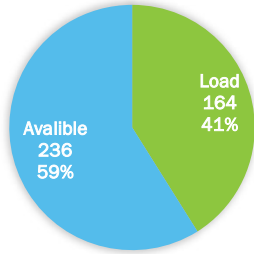

#### Electrical Service | Ampacity Summary | Project Impact

Total Capacity	Current Load	Cummulative Ampacity @ Building Voltage
400	164	346

Good

### Electrical Service Summary

BUILDING: Library  
 SERVICE VOLTAGE: 208 V

Equipment	Rated Current	Rating Type	Equipment Voltage	QTY	ADDED CURRENT (AMPS) @ 208V
Remove Air Cooled Chiller	184	MCA	208	-1	-184
30 Ton Heat Pump	158	MCA	208	2	315.3021978
NEW Library Hot Water Loop Pumps (2)	3	FLA	208	2	6.209568688
Remove Old Library CHW Loop Pumps	3	FLA	208	-2	-6
NEW Library Chilled Water Loop Pumps (2)	2	FLA	208	2	3.104784344

**Current Electrical Capacity**

Total Added Amps 208V

134

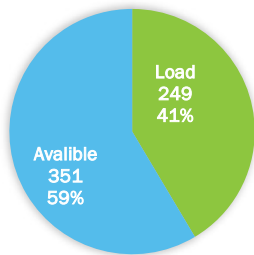

#### Electrical Service | Ampacity Summary | Project Impact

Total Capacity	Current Load	Cummulative Ampacity @ Building Voltage
600	249	383

Good



# appendix 4

---

schematics





VILLAGE OF HASTINGS-ON-HUDSON | GEOTHERMAL AND HEAT PUMP FEASIBILITY ASSESSMENT

7 Maple Ave  
Hastings-on-Hudson, NY 11238

ENERGY PROJECT



Centerpointe Corporate Park  
375 Esplanade, Suite 200  
Williamsville, NY 14221  
www.wendelcorp.com  
p:716.688.0766 f:716.625.6825

WENDEL ENGINEERING P.C.

CONTROL POINTS LIST	SOFTWARE POINTS				COMMENTS
	ANALOG VALUE	DIGITAL VALUE	TREND	ALARM	
SYSTEM: CHILLED WATER					
ⓐ: ANALOG INPUT		ⓓ: DIGITAL INPUT			
ⓑ: ANALOG OUTPUT		ⓔ: DIGITAL OUTPUT			
POINT DESCRIPTION					
1 PUMP STATUS	X	X	X	X	
2 PUMP ENABLE/DISABLE	X	X	X	X	
3 PUMP SPEED MODULATION	X	X	X	X	
4 DIFFERENTIAL PRESSURE	X	X	X	X	
5 HEAT PUMP CHILLED WATER SETPOINT	X	X	X	X	HARDWIRE TO CHILLER
6 HEAT PUMP HOT WATER SETPOINT	X	X	X	X	HARDWIRE TO CHILLER
7 CHILLER ENABLE/DISABLE	X	X	X	X	HARDWIRE TO CHILLER
8 CHILLER STATUS	X	X	X	X	
9 CHILLER ALARM	X	X	X	X	HARDWIRE TO CHILLER
10 HEAT PUMP KW METER	X	X	X	X	
11 TEMPERATURE SENSOR	X	X	X	X	
12 3-WAY MODULATING CONTROL VALVE	X	X	X	X	
13 PUMP STATUS	X	X	X	X	
14 HOT WATER SETPOINT	X	X	X	X	
15 BOILER ENABLE / DISABLE	X	X	X	X	
16 BOILER STATUS	X	X	X	X	
17 NOT USED					

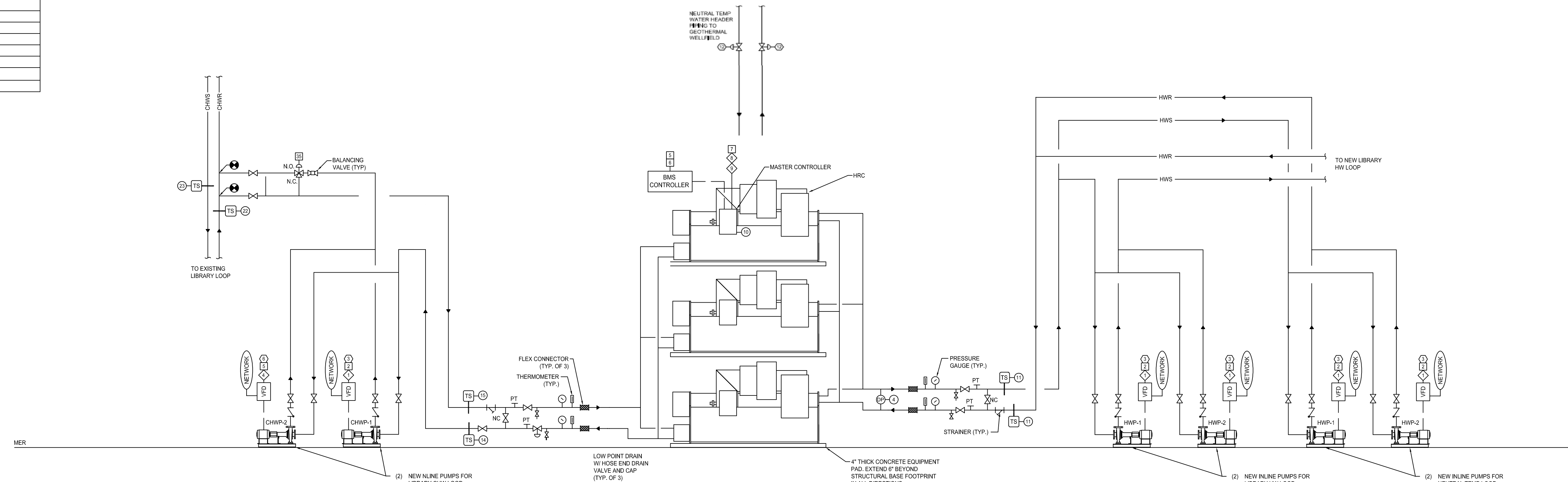

1 VILLAGE OF HASTINGS-ON-HUDSON | LIBRARY GEOTHERMAL HEAT PUMP SCHEMATIC  
SCALE: NONE

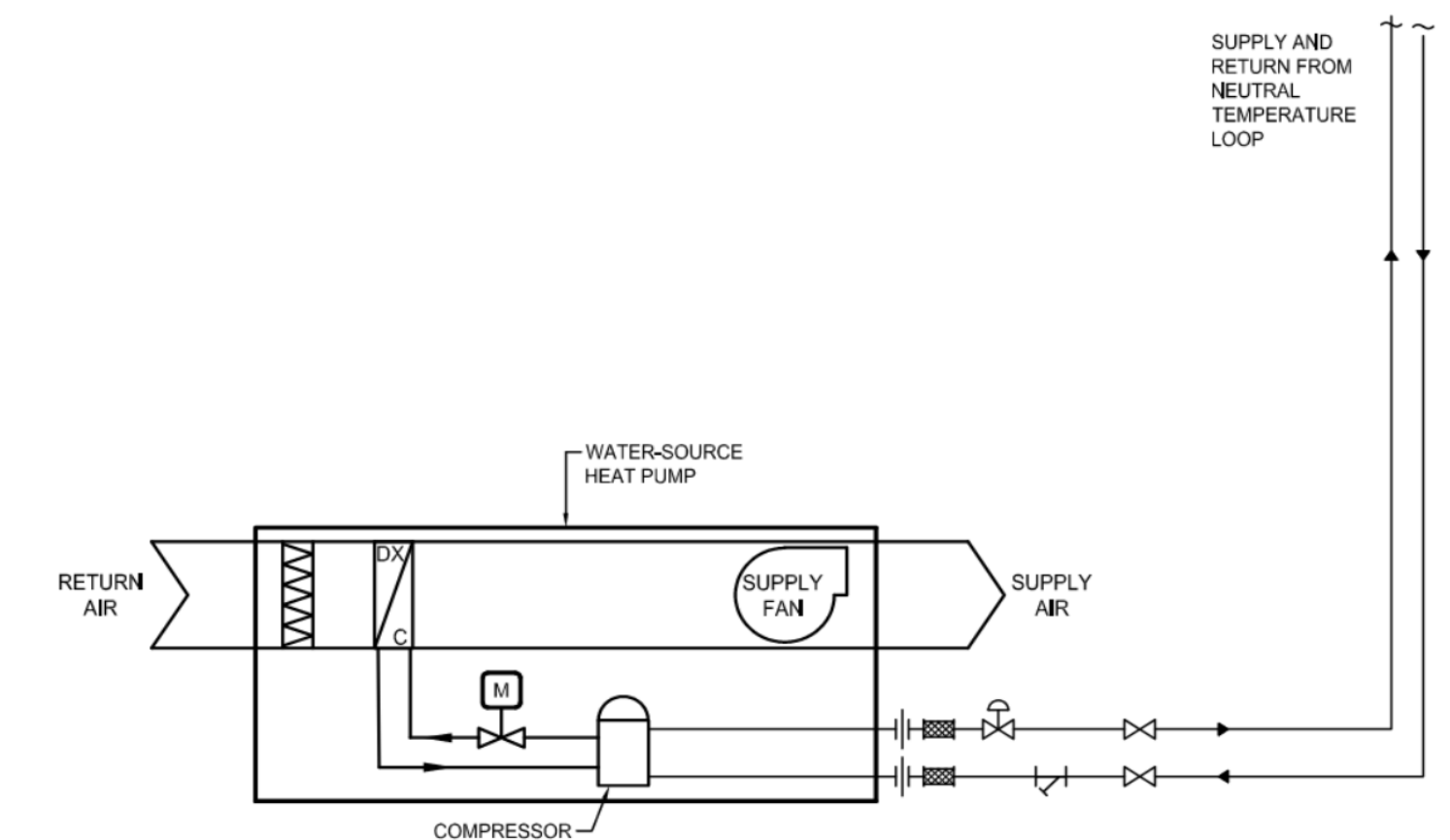

2 VILLAGE OF HASTINGS-ON-HUDSON | VILLAGE HALL GEOTHERMAL HEAT PUMP SCHEMATIC (TYP. OF 48)  
SCALE: NONE

NOTE:  
THIS DOCUMENT AND THE IDEAS AND DESIGN INCORPORATED HEREIN, AS AN INSTRUMENT OF PROFESSIONAL SERVICE, IS THE PROPERTY OF THE ARCHITECT AND ENGINEER AND IS NOT TO BE REPRODUCED OR TRANSMITTED IN ANY FORM OR BY ANY MEANS, ELECTRONIC OR MECHANICAL, INCLUDING PHOTOCOPYING, RECORDING, OR BY ANY INFORMATION STORAGE AND RETRIEVAL SYSTEM, WITHOUT THE WRITTEN PERMISSION OF THE ARCHITECT AND ENGINEER. UNAUTHORIZED ALTERATION OR ADDITION TO ANY SURVEY, DRAWING, DESIGN, SPECIFICATION, PLAN OR REPORT IS PROHIBITED IN ACCORDANCE WITH STATE LAW, CODES AND RULES.

NO.	REVISIONS	DATE

GEOTHERMAL SYSTEM SCHEMATICS

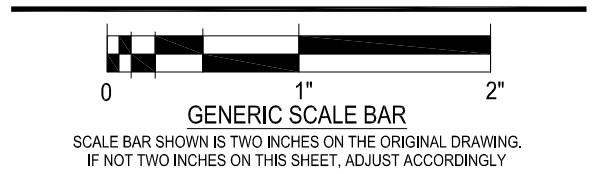

DATE: 6/30/23  
SCALE: AS NOTED  
DWN: JH4  
CHK: CHK  
PROJ. No.: 625801  
DWG. No.:

M1.1

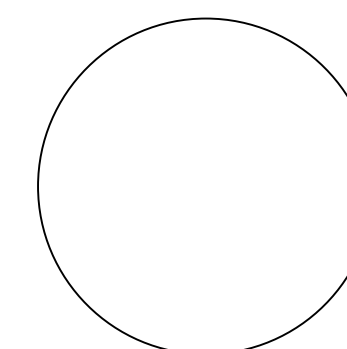

NOT FOR CONSTRUCTION

10		
09		
08		
07		
06		
05		
04		
03		
02		
01		
REV.	DATE	DESCRIPTION
DATE	07/14/2023	
CLIENT NAME	WENDEL	
CLIENT STREET	100 MOTOR PARKWAY, STE 410	
CLIENT CITY/STATE/ZIP	HAUPPAUGE, NY 11788	
PROJECT NAME	HASTINGS-ON-HUDSON MUNICIPAL BUILDINGS	
PROJECT STREET	7 MAPLE AVENUE	
PROJECT CITY/STATE/ZIP	HASTINGS-ON-HUDSON, NY 10706	
TAX NO.	XXXX-XXXXX-XX-XX	
PROJECT NO.	TBD	
CHECKED BY	GMG	
DRAWN BY	MTP	
SCALE	AS SHOWN	
SUBMISSION	FEASIBILITY ASSESSMENT	
DRAWING TITLE	GEOTHERMAL SITE PLAN	
DRAWING NO.	<b>GT-001.01</b>	
SHEET	1 OF 15	

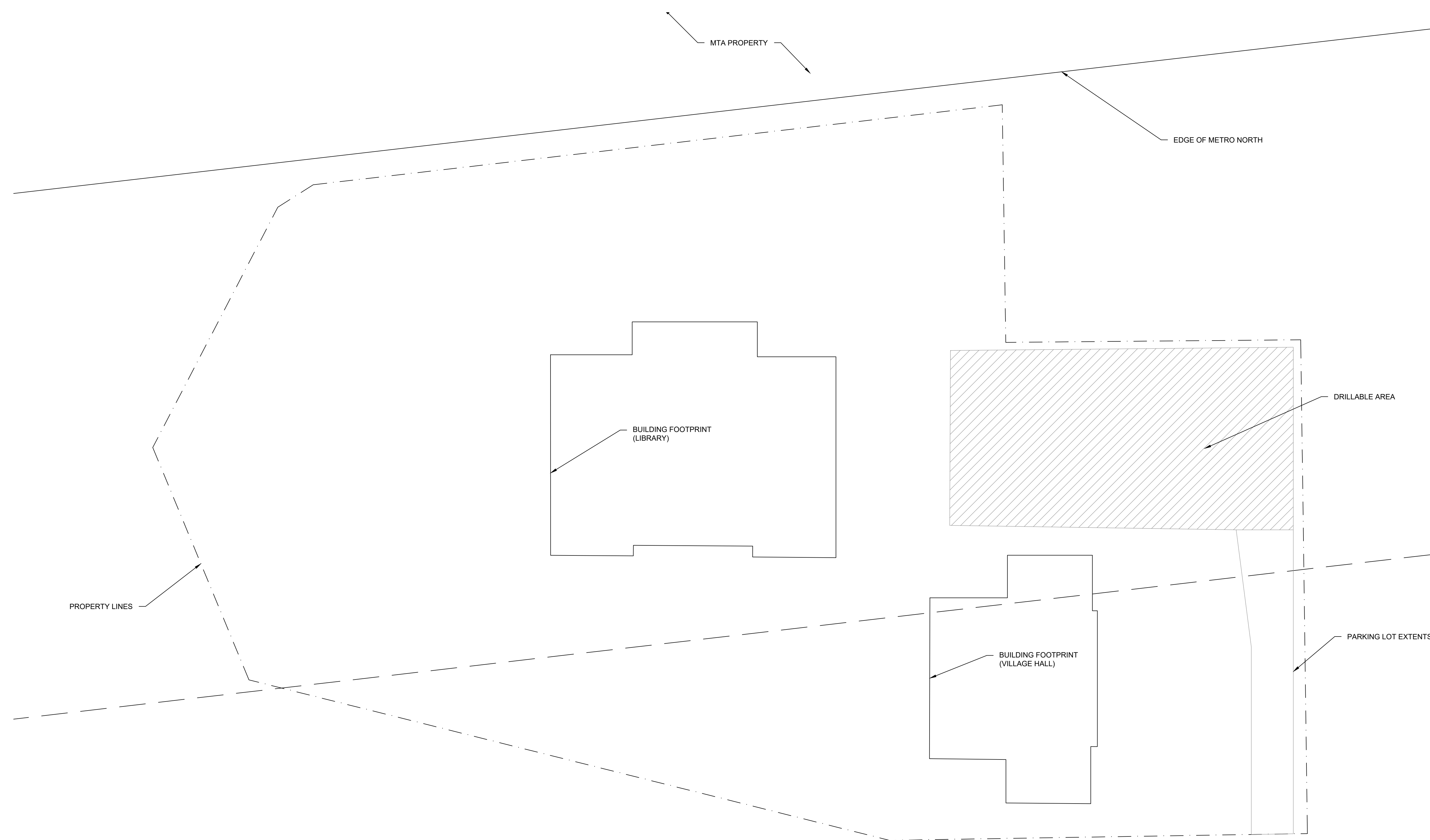

**LEGEND**

- DRILLABLE AREA
- PROPERTY LINE
- MTA LINE
- MTA 200' SETBACK

**NOTES:**

- BOREHOLES SHOWN ARE ASSUMED TO EXTEND 499' DEEP BELOW GRADE
- GEOTHERMAL HEAT EXCHANGER SIZE: 1-1/4"Ø
- NUMBER OF VERTICAL BOREHOLES: 20
- NUMBER OF VERTICALLY INCLINED BOREHOLES: 0
- TOTAL NUMBER OF BOREHOLES: 20

**REFERENCE:**

- EXISTING ARCHITECTURAL SITE PLAN FROM SWITZER & ZEGLER ARCHITECTS DATED 5/5/1965
- GOOGLE EARTH PRO .KMZ FILE PROVIDED BY WENDEL

**GEOTHERMAL EXISTING SITE PLAN**

SCALE: 1" = 20'

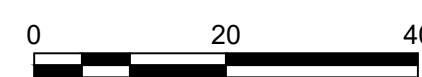



VILLAGE OF HASTINGS-ON-HUDSON | GEOTHERMAL AND HEAT PUMP FEASIBILITY ASSESSMENT

7 Maple Ave  
Hastings-on-Hudson, NY 11238

ENERGY PROJECT



Centerpointe Corporate Park  
375 Essjay Road, Suite 200  
Williamsville, NY 14221  
www.wendelcorp.com  
p: 716.688.0766 f: 716.625.6825

WENDEL ENGINEERING P.C.

CONTROL POINTS LIST	SOFTWARE POINTS				COMMENTS
	ANALOG VALUE	DIGITAL VALUE	TREND	ALARM	
SYSTEM: CHILLED WATER					
ⓐ: ANALOG INPUT		ⓓ: DIGITAL INPUT			
ⓑ: ANALOG OUTPUT		ⓔ: DIGITAL OUTPUT			
POINT DESCRIPTION	ANALOG VALUE	DIGITAL VALUE	TREND	ALARM	
1 PUMP STATUS		X	X	X	
2 PUMP ENABLE/DISABLE		X			
3 PUMP SPEED MODULATION	X		X	X	
4 DIFFERENTIAL PRESSURE	X		X	X	
5 HEAT PUMP CHILLED WATER SETPOINT	X		X	X	HARDWARE TO CHILLER
6 HEAT PUMP HOT WATER SETPOINT	X		X	X	HARDWARE TO CHILLER
7 CHILLER ENABLE/DISABLE		X			HARDWARE TO CHILLER
8 CHILLER STATUS		X	X	X	
9 CHILLER ALARM		X			HARDWARE TO CHILLER
10 HEAT PUMP KW METER	X		X	X	
11 TEMPERATURE SENSOR	X		X	X	
12 3-WAY MODULATING CONTROL VALVE	X		X	X	
13 PUMP STATUS	X	X	X	X	
14 HOT WATER SETPOINT	X				
15 BOILER ENABLE / DISABLE	X				
16 BOILER STATUS	X				
17 NOT USED					

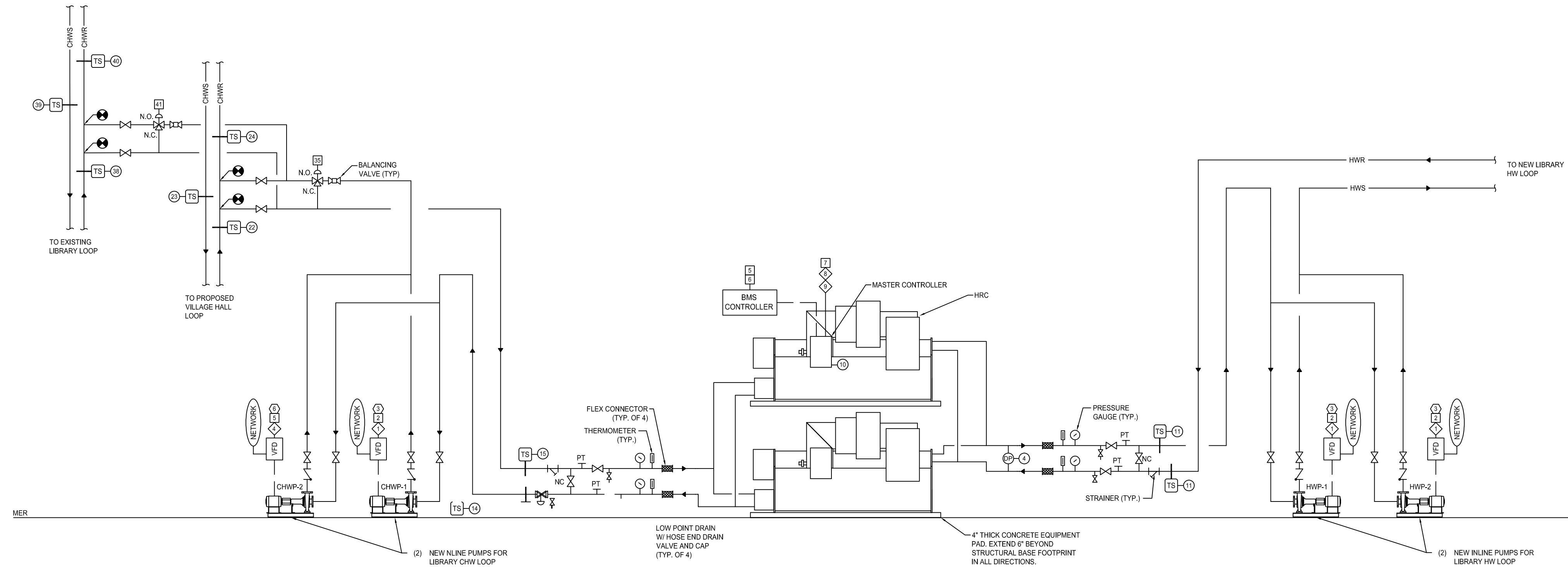

3 VILLAGE OF HASTINGS-ON-HUDSON | LIBRARY AIR SOURCE HEAT PUMP SCHEMATIC (TYP. OF 4)  
SCALE: NONE

CONTROL POINTS LIST	HARDWARE				SOFTWARE				BMS FUNCTION
	OUTPUT DIGITAL	ANALOG	INPUT DIGITAL	ANALOG	ALARMS DIGITAL	ANALOG			
SYSTEM:									
FAN COIL UNIT									
POINT DESCRIPTION	OUTPUT DIGITAL	ANALOG	INPUT DIGITAL	ANALOG	ALARMS DIGITAL	ANALOG			BMS FUNCTION
1 SUPPLY FAN STATUS			X	X	X	X			STATUS
2 CONDENSATE ALARM			X	X	X	X			ALARM
3 DISCHARGE TEMPERATURE			X	X	X	X			TEMPERATURE
4 HOT WATER CONTROL VALVE			X	X	X	X			CONTROL
5 FILTER PRESSURE			X	X	X	X			TEMPERATURE
6 SUPPLY FAN SPEED			X	X	X	X			TEMPERATURE
7 MIDDLE AIR TEMPERATURE			X	X	X	X			TEMPERATURE
8 RETURN AIR TEMPERATURE			X	X	X	X			TEMPERATURE
9 OUTDOOR AIR DAMPER WITH END SWITCH	X		X	X	X	X			TEMPERATURE
10 OUTDOOR AIR FLOW			X	X	X	X			TEMPERATURE
11 DISCHARGE TEMPERATURE #1 (FREEZE-40 DEG F)			X	X	X	X			TEMPERATURE
12 DISCHARGE TEMPERATURE #2 (FREEZE-40 DEG F)			X	X	X	X			TEMPERATURE
13 ACCU STATUS			X	X	X	X			TEMPERATURE
14 ACCU ALARM			X	X	X	X			TEMPERATURE
15 ACCU MANUALLY-ENABLED COOLING STAGE #1	X		X	X	X	X			TEMPERATURE
16 SPACE SENSOR			X	X	X	X			TEMPERATURE
17 READY ROOM OCCUPANCY SENSOR			X	X	X	X			TEMPERATURE

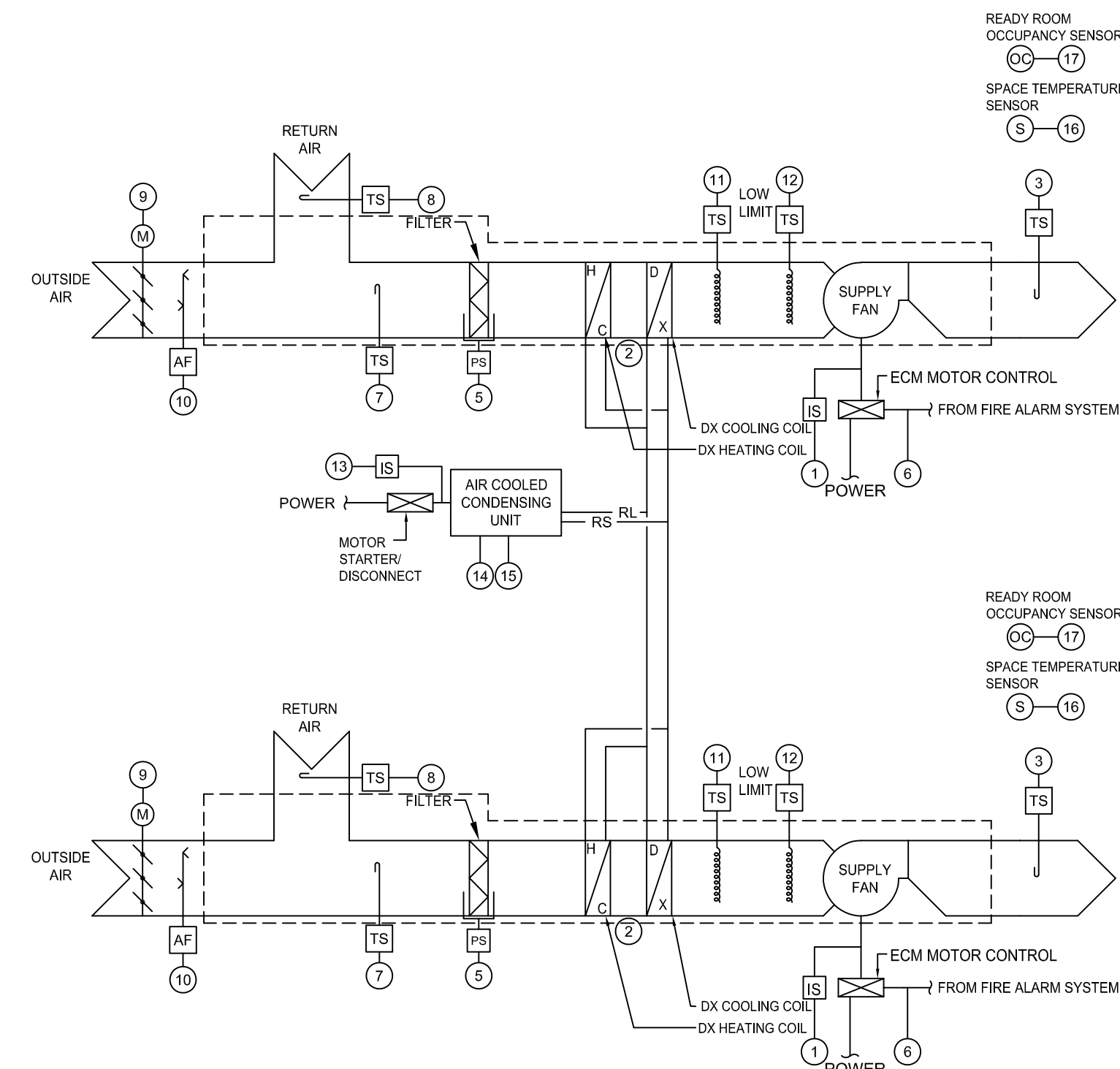

4 VILLAGE OF HASTINGS-ON-HUDSON | VILLAGE HALL FCU SCHEMATIC (TYP. OF 11)  
SCALE: NONE

NOTE:  
THIS DOCUMENT AND THE IDEAS AND DESIGNS INCORPORATED HEREIN, AS AN INSTRUMENT OF PROFESSIONAL SERVICE, IS THE PROPERTY OF THE ARCHITECT AND ENGINEER AND IS TO BE USED IN WHOLE OR IN PART FOR ANY OTHER PROJECT. WITHOUT THE WRITTEN PERMISSION OF THE ARCHITECT AND ENGINEER, UNAUTHORIZED ALTERATION OR REPRODUCTION OF ANY SURVEY, DRAWING, DESIGN, SPECIFICATION, PLAN OR REPORT IS STRICTLY PROHIBITED IN ACCORDANCE WITH STATE LAW, CODE AND RULES.

NO.	REVISIONS	DATE

DWG. TITLE

AIR SOURCE SYSTEM SCHEMATICS

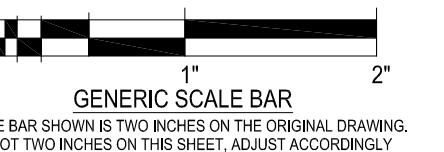

DATE: 6/30/23  
SCALE: AS NOTED  
DWN: JH4  
CHK: CHK  
PROJ. NO.: 625801  
DWG. NO.:

M1.2





# appendix 5

---

cut sheets





# 1.1 - Library Heat Recovery Chiller

ER

Job Name **Sample - Would require 3-4 modules**  
 Location  
 Engineer  
 Contractor

Job Number  
 Quote Number  
 Representative  
 Rep Office

QTDELUCA03272023-2  
 Tyler DeLuca  
 New York City

Mechanical Modules: (1) MSH010XNACEAAA--BB-B--AAJ-CA-B  
 Accessory Modules:

SUMMARY PERFORMANCE DATA													
Load	Capacity (tons)	Input kW	THR (MBtu/h)	kW/Ton	EER (Btu/Wh)	COP (kW/kW)	EVAPORATOR			CONDENSER			
							Flow Rate (GPM)	Leaving Temp. °F	ΔP (ft H2O)	Cond Flow (GPM)	Entering Temp. °F	Leaving Temp. °F	ΔP (ft H2O)
100%	9.120	11.05	0.1472	1.212	9.902	2.900	21.85	44.00	5.045	29.55	110.0	120.0	7.726
75%	6.840	8.319	0.1105	1.216	9.866	2.890	21.85	44.00	5.045	29.55	112.4	120.0	7.726
50%	4.560	5.707	0.07420	1.252	9.587	2.810	21.85	44.00	5.045	29.55	114.9	120.0	7.726
25%	2.280	2.963	0.03747	1.300	9.234	2.710	21.85	44.00	5.045	29.55	117.4	120.0	7.726

The 25, 50 % points have incorporated a cycling penalty per AHRI 550/590.

Cooling COP	Heating COP	Heating and Cooling COP
2.900	3.900	6.800

No Tower Relief	PLV	kW/Ton	EER (Btu/Wh)	COP (kW/kW)
		1.242	9.665	2.835

EVAPORATOR DESIGN DATA (Based on Water)	
Entering Temperature °F	54.00
Leaving Temperature °F	44.00
Design Flow (GPM)	21.80
Pressure Drop (Full Load)	2.184 PSI / 5.045 ft H2O
Chiller Minimum Flow (GPM)	21.80
Min. GPM For Sizing System Bypass	21.80
Heat Exchanger Style	Brazed Plate
Fouling Factor (h-ft <sup>2</sup> -°F/Btu)	.000100
Header Size (in.)	6
Header Connection Type	Grooved Coupling

CONDENSER DESIGN DATA (Based on Water)	
Entering Temperature °F	110.0
Leaving Temperature °F	120.0
Design Flow (GPM)	29.50
Pressure Drop (Full Load)	3.345 PSI / 7.726 ft H2O
Chiller Minimum Flow (GPM)	29.50
Min. GPM For Sizing System Bypass	29.50
Heat Exchanger Style	Brazed Plate
Fouling Factor (h-ft <sup>2</sup> -°F/Btu)	.000100
Header Size (in.)	6
Header Connection Type	Grooved Coupling

PHYSICAL DATA	Section 1	Section 2
Length (in.)	28	
Width (in.)	47.625	
Height (in.)	62.875	
Estimated Dry Weight (lbs.)	1330	
Estimated Operating Weight (lbs.)	1490	
Refrigerant Type	R-410A	
Refrig. Charge (lbs/circuit)	5.5	

ELECTRICAL DATA (Direct Connect-Per Module)	MCA	MOP
(1) MSH010X	54	80
MCA		
MOP		
Voltage	208/60/3	

Dimensions are estimated and do not include frames, J-boxes, Multiflush, etc

CHILLER DATA	
Compressor Description	Scroll
Compressor RLA (per comp.)	23.8

MOUNTING/LIFTING FRAME	
Materials	Option Not Selected
I-Beam Size	Option Not Selected
Bolt together frame - # of pieces	Option Not Selected
End Type	Option Not Selected

\*Parallel feeds not required (Assumes no larger than 250 MCM/kcmil wire)

Software Version# : 1.0.4435.69400

Performance Run Date: 3/27/2023 3:45:09 PM

Outside the scope of AHRI Standard 550/590 (I-P).



## **Product Overview:**

<b>Model Description</b>	<b>Compressor Description</b>
<b>(1) MSH010X</b>	<b>Water Cooled Modular Scroll</b>

## **Services & Special Features:**

- Chiller Waterside Maximum Working Pressure is 150 PSIG
- Heat exchanger maximum working pressure (refrigerant 650 PSI)
- Lead compressor sequencing (24hrs)
- Automatic internal rescheduling if fault occurs
- Multiple, independent refrigeration systems
- Automatic logging of any fault condition
- Electronic chilled water control
- Quick interconnect modular design
- Filters in evaporator and condenser supply headers
- Stainless steel evaporator and condenser inlet header
- Electrical design intended for Design
- R-410A Refrigerant
- 5kA SCCR
- Electrical Connection Type - Direct Connect
- 5 Year Warranty: Compressor
- 1 Year Warranty: All Parts
- Dedicated Heat Recovery Controls
- Power Phase Monitor (for Direct Connect per module)
- ¾" Insulation (Evaporator)
- ¾" Insulation (Condenser)
- Evap Flow Switch-Thermal Dispersion Type (24 Volt Factory Powered & Installed On Each Module)
- Cond Flow Switch-Thermal Dispersion Type (24 Volt Factory Powered & Installed On Each Module)

## **Excluded By Multistack:**

- Acoustical Panels - indoor rated
- Multiflush™ (Debris Removal System) - Cond
- Interconnecting piping between sections if two sections exist.
- Multistack recommends a 2-3 minute minimum loop time. Contact Multistack if you have questions regarding system loop time design
- Variable speed scroll modules require proper differential pressure for reliable operation. Removing condenser variable flow valves removes module level head pressure control which does provide this differential for reliable operation. External control is required with this option deleted as to ensure proper pressure at all times. Contact Inside Sales for further details.<br />

REVISION	DATE	BY
I		
F		
D		

PLAN VIEW

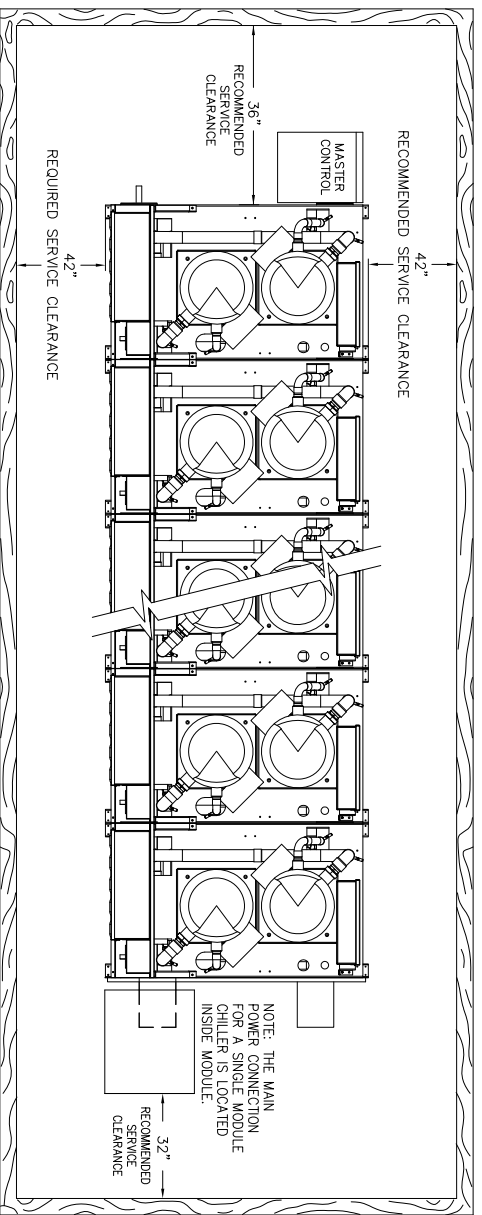

MULTISTACK		C 500-0329	
SPORTA, Wisconsin 54656	ALL DIMENSIONS IN INCHES / DO NOT SCALE DRAWINGS	DATE: 3/27/12	SCALE: NONE
SIMILAR TO:	ASSY NO.:	CHECKED BY:	DATE:
SUBMITTAL WATER COOLED DHRC M510X-70X STANDARD NO PANELS			

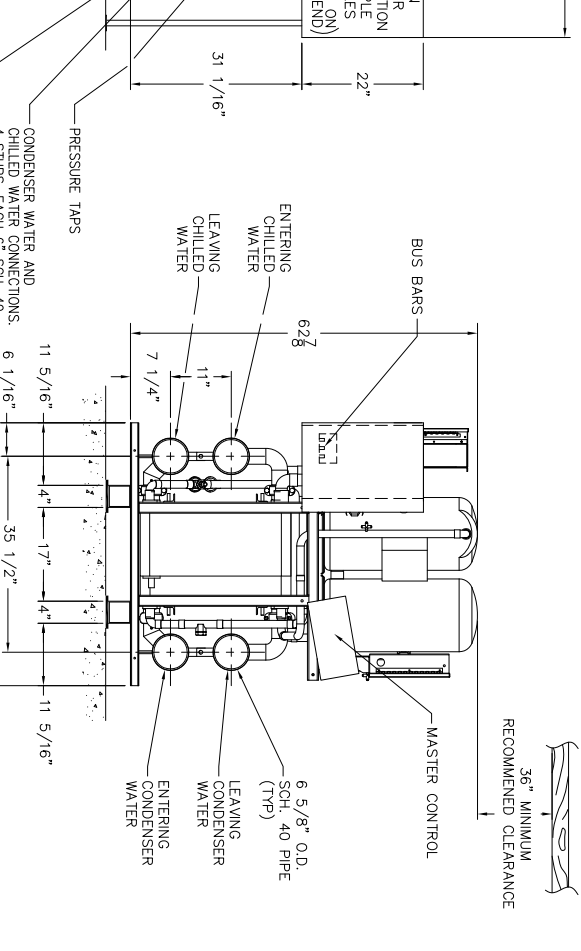
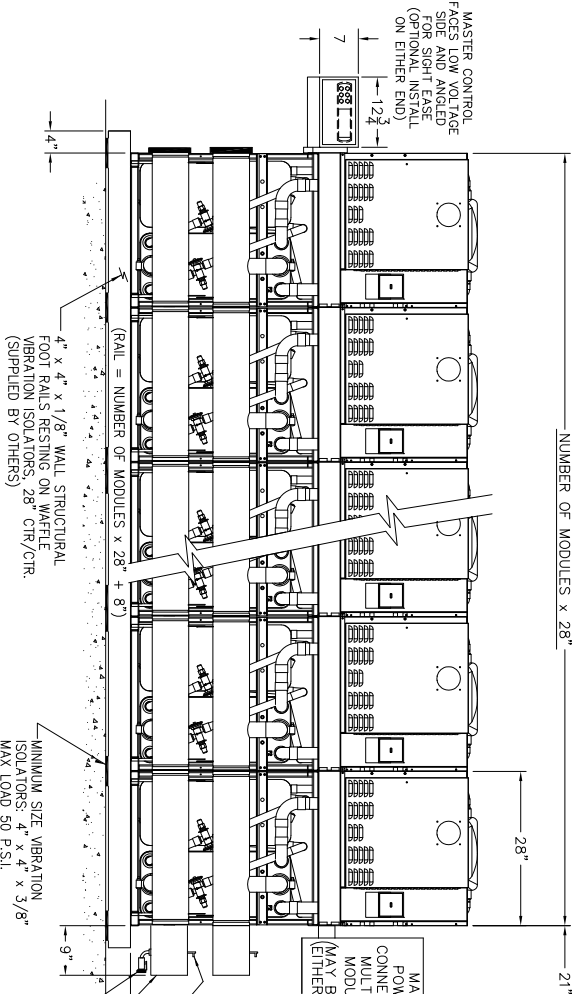

1 2 3 4 5 6 7 8 9 10 11

C 500-0329

<b>Job/Project:</b>	<b>Representative: Wallace Eannace Associates</b>		
<b>ESP-Systemwize: WIZE-897C0BF9</b>	<b>Created On: 06/23/2023</b>	<b>Phone: (516) 454-9300</b>	
<b>Location/Tag:</b>	<b>Email: info-ny@wea-inc.com</b>		
<b>Engineer:</b>	<b>Submitted By:</b>	<b>Date:</b>	
<b>Contractor:</b>	<b>Approved By:</b>	<b>Date:</b>	

### Base Mounted End Suction Pump

**Series: e-1510**

**Model: 1.25AD-es**

#### Features & Design

- ANSI/OSHA Coupling Guard
- Center Drop Out Spacer Coupling
- Fabricated Heavy Duty Baseplate
- Internally Self-Flushing Mechanical Seal



\*The Bell & Gossett Series e-1510 is available in 26 sizes and a variety of configuration options that enable customization and flexibility to fit a broad range of operating conditions.

<http://bellgossett.com/pumps-circulators/end-suction-pumps/e-1510/>

### Pump Selection Summary

Duty Point Flow	32.8 US gpm
Duty Point Head	32 ft
Control Head	9.6 ft
Duty Point Pump Efficiency	60.7 %
Part Load Efficiency Value (PLEV)	53.1 %
Impeller Diameter	5.75 in
Motor Power	0.75 hp
Duty Point Power	0.435 bhp
Motor Speed	1800 rpm
RPM @ Duty Point	1674 rpm
NPSHr	2.79 ft
Minimum Shutoff Head	33.2 ft
Minimum Flow at RPM	6.86 US gpm
Flow @ BEP	45.7 US gpm
Fluid Temperature	55 °F
Fluid Type	Water
Weight (approx. - consult rep for exact)	130 lbs
Pump Floor Space Calculation	2.64 ft <sup>2</sup>

### Performance Curve

#### Energy Efficiency Ratings:

Pump & Motor PEIcI: 0.78 ERcI: 22  
Pump, Motor & Drive: PEIvI: 0.44 ERvI: 56



**e-1510**  
**1.25AD-es**  
**1674 RPM**

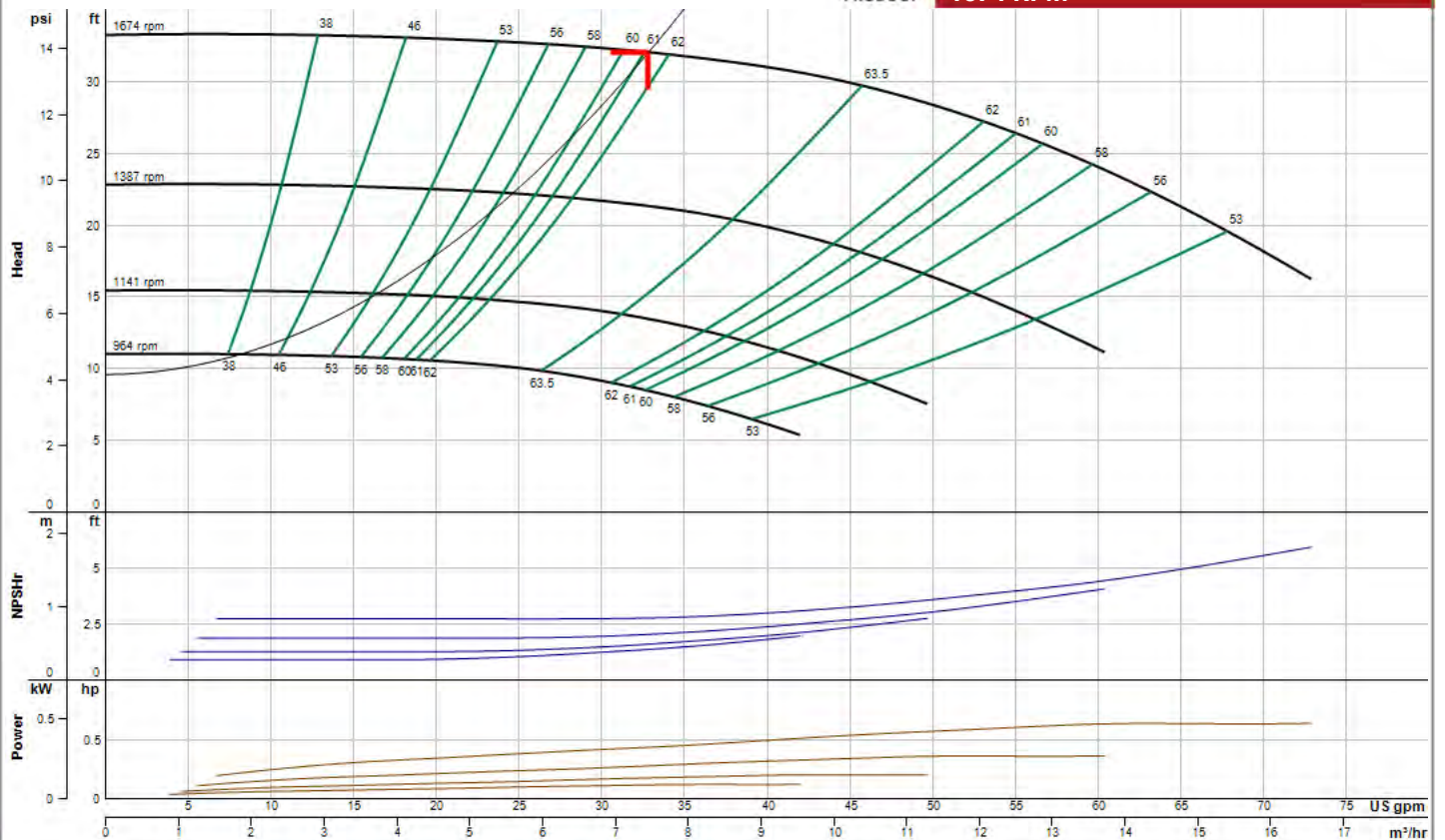



# Constant Speed Curve (1750 rpm)

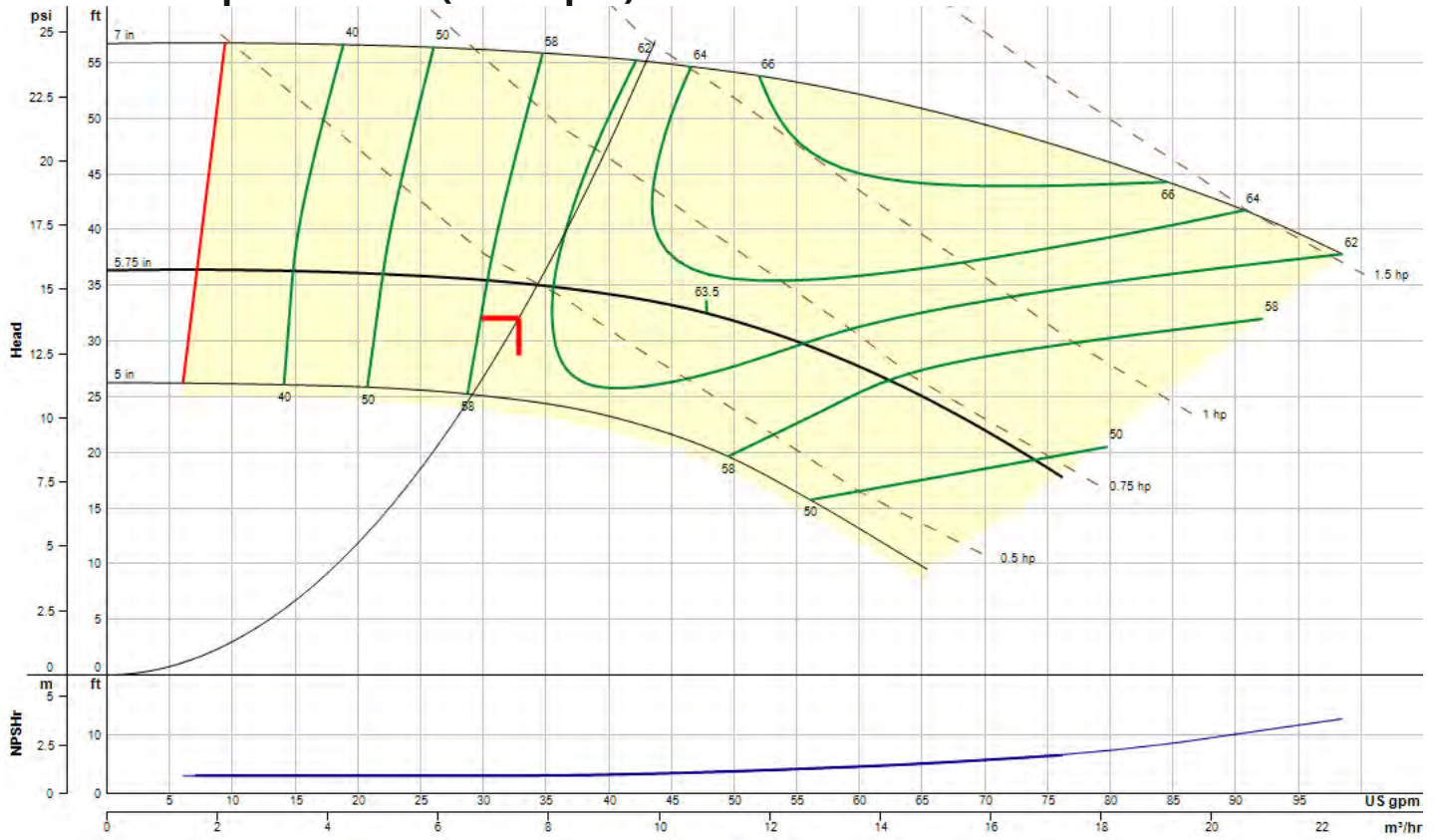

## Operating Point

Flow: 32.8 US gpm Head: 32 ft Speed: 1674 Efficiency: 60.7% Point BHP: 0.435 End Of Curve: 45%

## Maximum Duty Point (at rated motor speed)

Flow: 34.3 US gpm Head: 35 ft Speed: 1750 Efficiency: 61% Point BHP: 0.497 NOL Flow: 76.2 US gpm Runout Flow: 76.2 US gpm NOL (BHP): 0.727



1-1/4 NPT DISCHARGE  
DETAILS

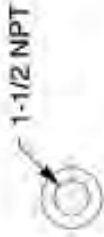

1-1/2 NPT SUCTION  
DETAILS

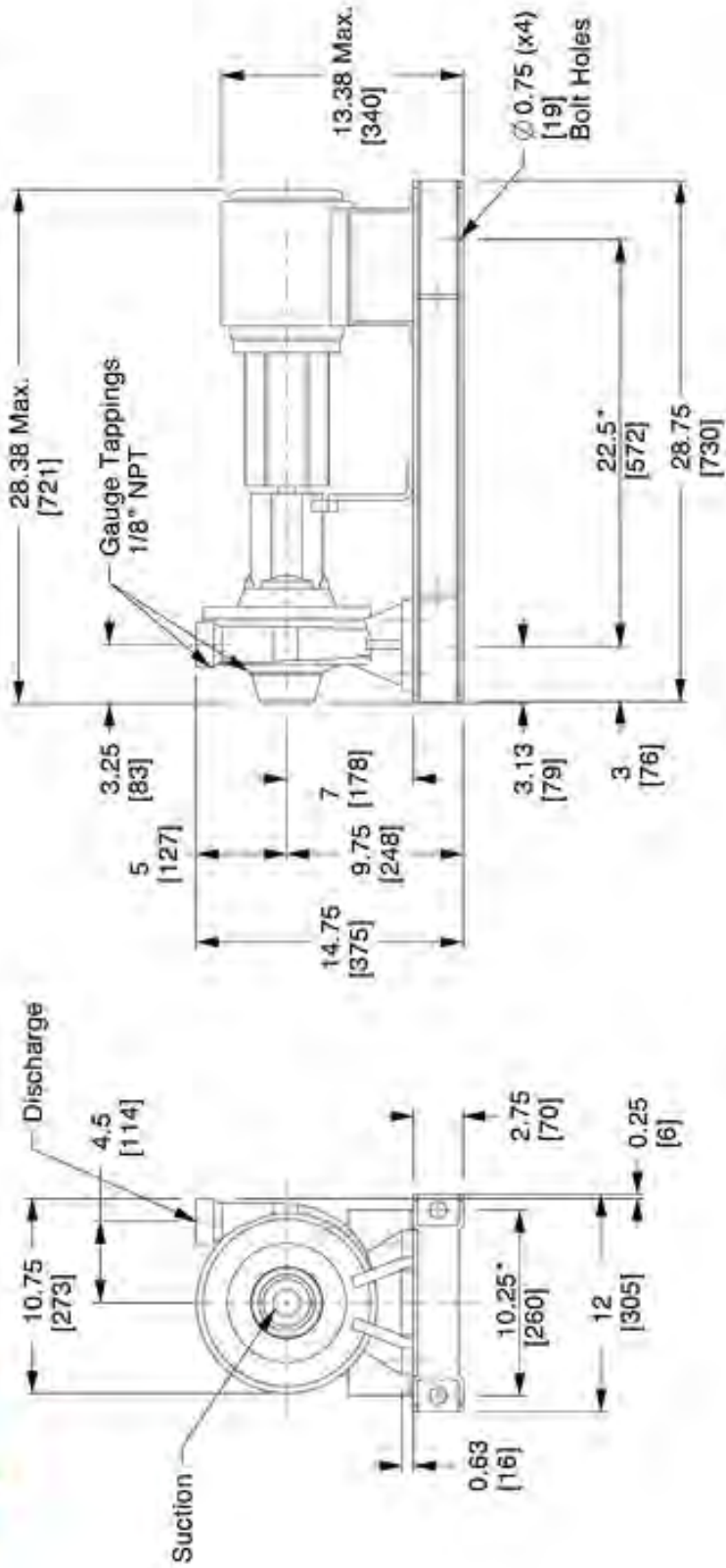

\* Dist. Between Bolt Holes

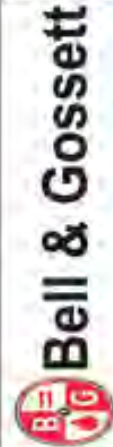

8200 N. Austin Ave.  
Morton Grove, IL 60053, USA

This drawing and the information depicted therein is the property of Xylem. Copies are issued in strict confidence and shall not be reproduced or copied, or used as the basis for the manufacture or sale of products without prior written permission of Xylem.

Dimensions are subject to change  
Not to be used for construction unless certified

## BG-E1510-1P25ADES-SS-56

Series e-1510 Centrifugal Pumps - Base Mounted  
Seal Type: Standard Seal | Motor Frame: 56 | Frame Type: ea

Dimensions : IN (mm)

Scale : N.T.S.

Submittal # : B-890B

## Standard Mechanical Configuration

Standard Mechanical Seal	SM, LG, & XL Bearing Frames	ES Bearing Frame
Temperature Range	-20 to 225°F	-20 to 225°F
Maximum Pressure	175 PSI	175 PSI
pH Limitations	7.0 - 9.0	7.0 - 9.0
Elastomer	Buna	Buna
Rotating Face	Carbon	Carbon
Stationary Face	Ceramic	Silicon Carbide
Hardware	Stainless Steel / Brass	Stainless Steel

Mechanical Seal Options	SM, LG, & XL Bearing Frames		
Temperature Range	-20 to 250°F	-10 to 225°F	-20 to 250°F
Maximum Pressure	175 PSI	175 PSI	175 PSI
pH Limitations	7.0 - 11.0	7.0 - 9.0	7.0 - 12.5.0
Elastomer	EPR (Ethylene Propylene Rubber)	FKM (Viton™ or Fluoroelastomer)	EPR (Ethylene Propylene Rubber)
Rotating Face	Carbon	Carbon	Silicon Carbide
Stationary Face	Tungsten Carbide	Ceramic	Silicon Carbide
Hardware	Stainless Steel / Brass	Stainless Steel	Stainless Steel

Mechanical Seal Options	ES Bearing Frame		
Temperature Range	-20 to 250°F	-10 to 225°F	-20 to 250°F
Maximum Pressure	175 PSI	175 PSI	175 PSI
pH Limitations	7.0 - 11.0	7.0 - 9.0	7.0 - 12.5.0
Elastomer	EPR (Ethylene Propylene Rubber)	FKM (Viton™ or Fluoroelastomer)	EPR (Ethylene Propylene Rubber)
Rotating Face	Silicon Carbide	Carbon	Silicon Carbide
Stationary Face	Tungsten Carbide	Silicon Carbide	Silicon Carbide
Hardware	Stainless Steel / Brass	Stainless Steel	Stainless Steel

## Stuffing Box Configuration

Mechanical Seal	SM, LG, & XL Bearing Frames
Temperature Range	-20 to 250°F*
Maximum Pressure	175 PSI (Optional 250 PSI)
pH Limitations	7.0 - 11.0
Elastomer	EPR (Ethylene Propylene Rubber)
Rotating Face	Tungsten Carbide
Stationary Face	Carbon
Hardware	Stainless Steel

Packing Option	
Temperature Range	0 to 250°F
Maximum Pressure	175 PSI
pH Limitations	7.0 - 9.0
Material	Braided Graphite Impregnated PTFE

\* For operating temperatures above 250°F a cooled flush is required and is recommended for temperatures above 225°F for optimum seal life. On closed systems cooling is accomplished by inserting a small heat-exchanger in the flush line to cool the seal flushing fluid.

Flush-line Filters and Sediment Separators are available on special request.

## Materials of Construction

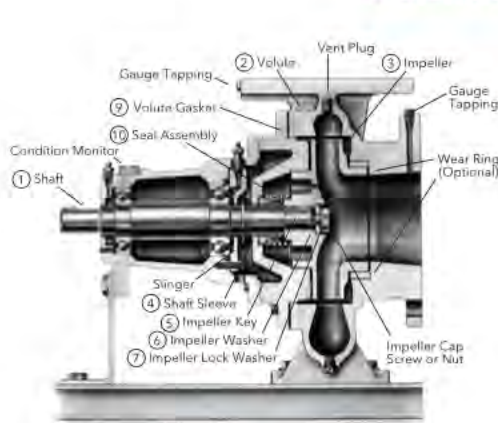

Standard Configuration

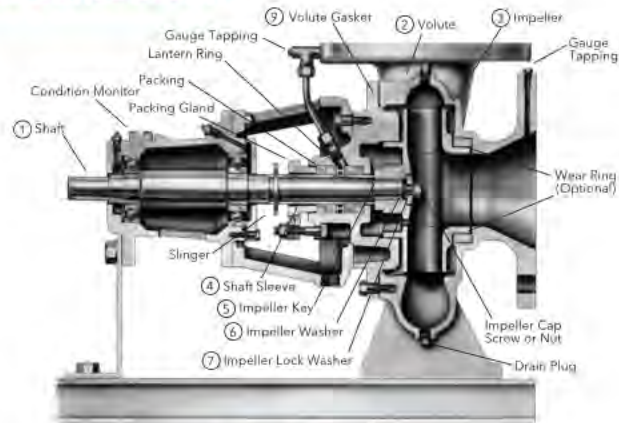

Optional - S Configuration

Description	SM, LG, & XL Bearing Frames	ES Bearing Frame
1 Shaft	ASTM 108 Grade 1144	ASTM 108 Grade 1144
2 Volute	Cast Iron ASTM A48 Class 30B	Cast Iron ASTM A48 Class 30B
3 Impeller	ASTM A743 Grade CF8 - 304 Stainless Steel	ASTM A743 Grade CF8 - 304 Stainless Steel
4 Shaft Sleeve	ASTM 312 Grade TP304 - 304 Stainless Steel	ASTM 312 Grade TP304 - 304 Stainless Steel
5 Impeller Key	#304 Stainless Steel	NA
6 Impeller Washer	Steel	NA
7 Impeller Lock Washer	#304 Stainless Steel (18-8 XL FRM)	NA
8 Impeller Cap Screw	#304 Stainless Steel	NA
8 Impeller Nut	NA	316 Stainless Steel
9 Volute Gasket	Cellulose Fiber	Cellulose Fiber
10 Seal Assembly	Reference Seal Data Tables	Reference Seal Data Tables

## Pump Options

- Stainless Steel Volute Wear Ring
- Galvanized Steel Drip Pan
- Stainless Steel Shaft
- Rexnord Omega Spacer Coupling
- Falk T31 Spacer Coupling
- External Flush Line
- Stuffing Box Configuration
- Epoxy Coated Internal Cast Iron Components
- Special Impeller Balancing (ISO 1940 G2.5 or G1.0)
- Certified Performance Tests (Per HI Standard 14.6)
- 250 PSI Working Pressure



<b>Job/Project:</b>	<b>Representative: Wallace Eannace Associates</b>		
<b>ESP-Systemwize: WIZE-A2B7A736</b>	<b>Created On: 06/23/2023</b>	<b>Phone: (516) 454-9300</b>	
<b>Location/Tag:</b>	<b>Email: info-ny@wea-inc.com</b>		
<b>Engineer:</b>	<b>Submitted By:</b>	<b>Date:</b>	
<b>Contractor:</b>	<b>Approved By:</b>	<b>Date:</b>	

### Base Mounted End Suction Pump

**Series: e-1510**

**Model: 1.25AD-es**

#### Features & Design

- ANSI/OSHA Coupling Guard
- Center Drop Out Spacer Coupling
- Fabricated Heavy Duty Baseplate
- Internally Self-Flushing Mechanical Seal



\*The Bell & Gossett Series e-1510 is available in 26 sizes and a variety of configuration options that enable customization and flexibility to fit a broad range of operating conditions.

<http://bellgossett.com/pumps-circulators/end-suction-pumps/e-1510/>

#### Pump Selection Summary

Duty Point Flow	22.1 US gpm
Duty Point Head	45 ft
Control Head	13.5 ft
Duty Point Pump Efficiency	47.7 %
Part Load Efficiency Value (PLEV)	39.6 %
Impeller Diameter	6.875 in
Motor Power	1.5 hp
Duty Point Power	0.514 bhp
Motor Speed	1800 rpm
RPM @ Duty Point	1594 rpm
NPSHr	2.49 ft
Minimum Shutoff Head	45.3 ft
Minimum Flow at RPM	8.31 US gpm
Flow @ BEP	55.4 US gpm
Fluid Temperature	120 °F
Fluid Type	Water
Weight (approx. - consult rep for exact)	150 lbs
Pump Floor Space Calculation	2.64 ft <sup>2</sup>

### Performance Curve

#### Energy Efficiency Ratings:

Pump & Motor PEIcI: 0.78 ERcI: 22  
Pump, Motor & Drive: PEIvI: 0.44 ERvI: 56



**e-1510**  
**1.25AD-es**  
**1594 RPM**

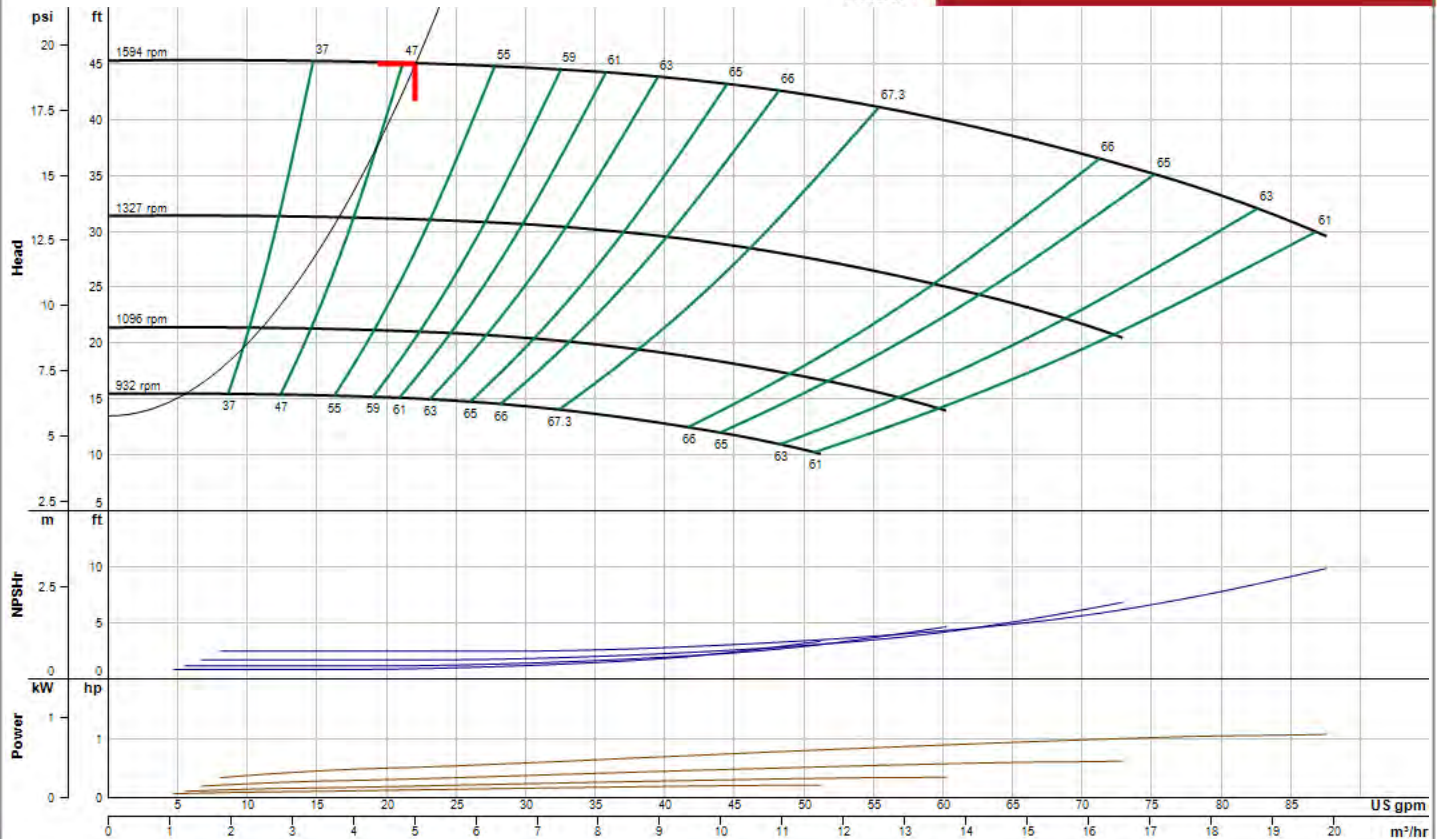



# Constant Speed Curve (1750 rpm)

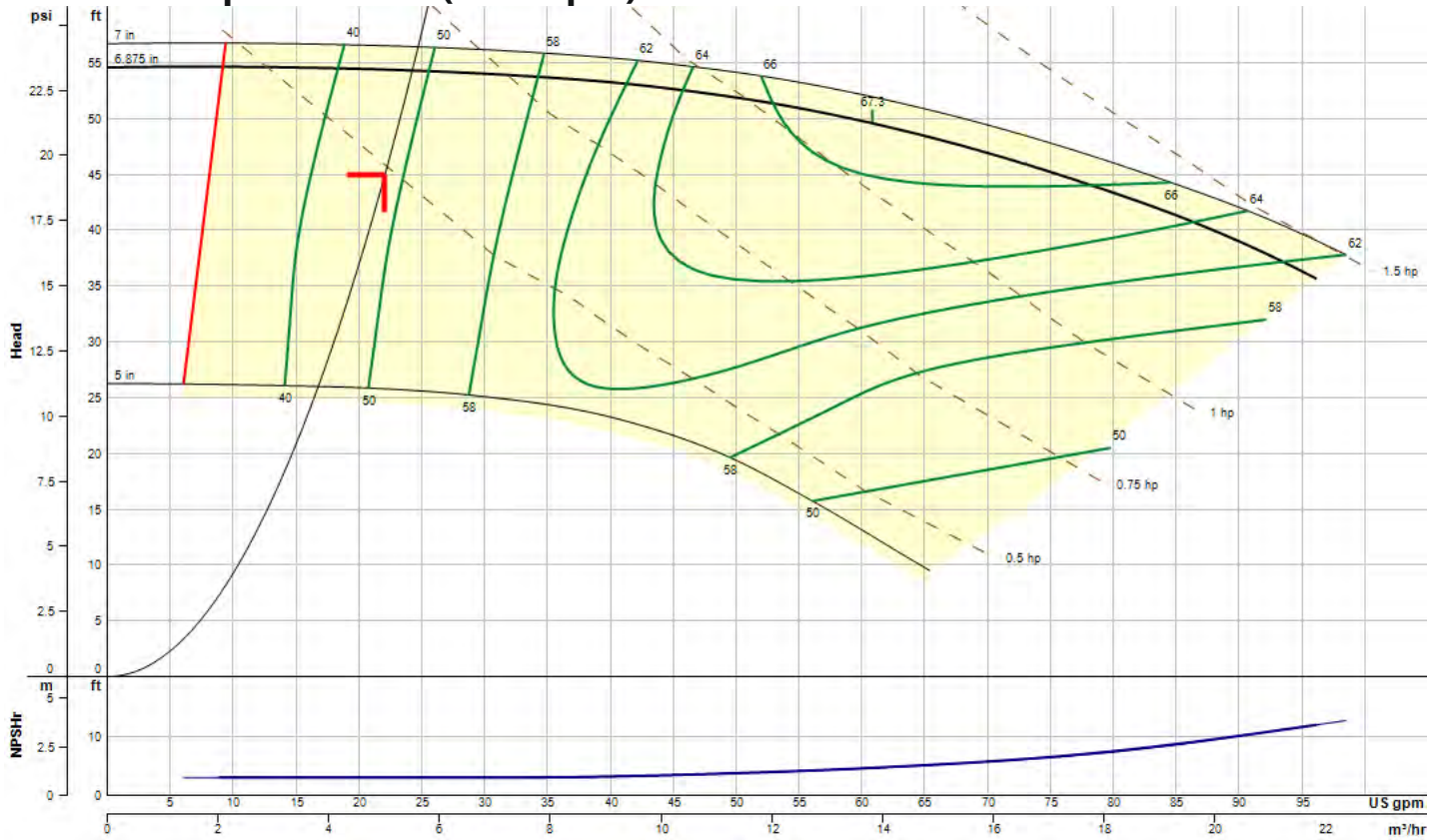

## Operating Point

Flow: 22.1 US gpm Head: 45 ft Speed: 1594 Efficiency: 47.7% Point BHP: 0.514 End Of Curve: 25.2%

## Maximum Duty Point (at rated motor speed)

Flow: 24.3 US gpm Head: 54.3 ft Speed: 1750 Efficiency: 48.2% Point BHP: 0.68 NOL Flow: 96.2 US gpm Runout Flow: 96.2 US gpm NOL (BHP): 1.42



**1-1/4 NPT DISCHARGE  
DETAILS**

**1-1/2 NPT SUCTION  
DETAILS**

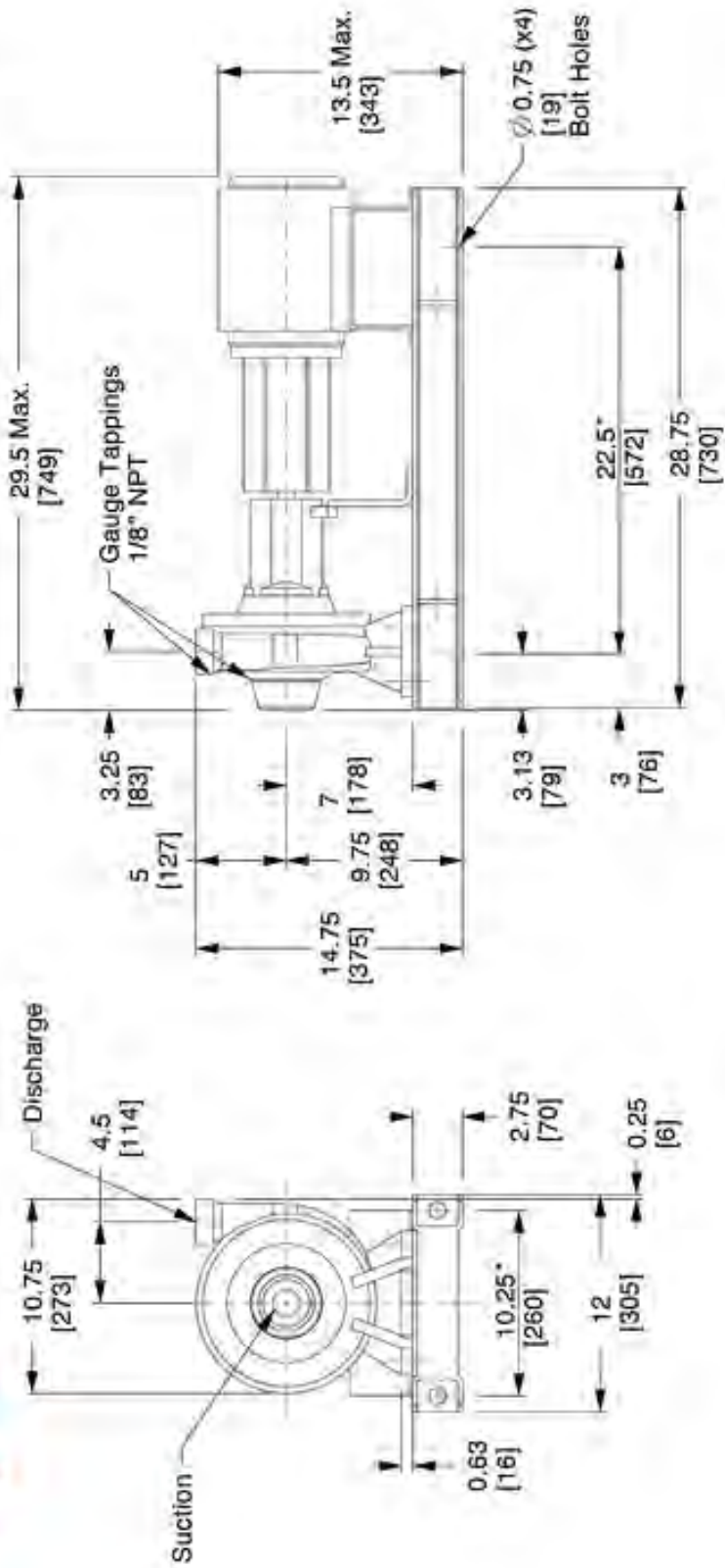

\* Dist. Between Bolt Holes

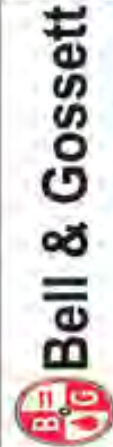

a xylem brand

8200 N. Austin Ave.  
Morton Grove, IL 60053, USA

This drawing and the information depicted therein is the property of Xylem. Copies are issued in strict confidence and shall not be reproduced or copied, or used as the basis for the manufacture or sale of products without prior written permission of Xylem.

Dimensions are subject to change  
Not to be used for construction unless certified

**BG-E1510-1P25ADES-SS-145T**

Series e-1510 Centrifugal Pumps - Base Mounted

Seal Type: Standard Seal | Motor Frame: 145T | Frame Type: eS

Dimensions : IN (mm)

Scale : N.T.S.

Submittal # : B-890B

## Standard Mechanical Configuration

Standard Mechanical Seal	SM, LG, & XL Bearing Frames	ES Bearing Frame
Temperature Range	-20 to 225°F	-20 to 225°F
Maximum Pressure	175 PSI	175 PSI
pH Limitations	7.0 - 9.0	7.0 - 9.0
Elastomer	Buna	Buna
Rotating Face	Carbon	Carbon
Stationary Face	Ceramic	Silicon Carbide
Hardware	Stainless Steel / Brass	Stainless Steel

Mechanical Seal Options	SM, LG, & XL Bearing Frames		
Temperature Range	-20 to 250°F	-10 to 225°F	-20 to 250°F
Maximum Pressure	175 PSI	175 PSI	175 PSI
pH Limitations	7.0 - 11.0	7.0 - 9.0	7.0 - 12.5.0
Elastomer	EPR (Ethylene Propylene Rubber)	FKM (Viton™ or Fluoroelastomer)	EPR (Ethylene Propylene Rubber)
Rotating Face	Carbon	Carbon	Silicon Carbide
Stationary Face	Tungsten Carbide	Ceramic	Silicon Carbide
Hardware	Stainless Steel / Brass	Stainless Steel	Stainless Steel

Mechanical Seal Options	ES Bearing Frame		
Temperature Range	-20 to 250°F	-10 to 225°F	-20 to 250°F
Maximum Pressure	175 PSI	175 PSI	175 PSI
pH Limitations	7.0 - 11.0	7.0 - 9.0	7.0 - 12.5.0
Elastomer	EPR (Ethylene Propylene Rubber)	FKM (Viton™ or Fluoroelastomer)	EPR (Ethylene Propylene Rubber)
Rotating Face	Silicon Carbide	Carbon	Silicon Carbide
Stationary Face	Tungsten Carbide	Silicon Carbide	Silicon Carbide
Hardware	Stainless Steel / Brass	Stainless Steel	Stainless Steel

## Stuffing Box Configuration

Mechanical Seal	SM, LG, & XL Bearing Frames
Temperature Range	-20 to 250°F*
Maximum Pressure	175 PSI (Optional 250 PSI)
pH Limitations	7.0 - 11.0
Elastomer	EPR (Ethylene Propylene Rubber)
Rotating Face	Tungsten Carbide
Stationary Face	Carbon
Hardware	Stainless Steel

Packing Option	
Temperature Range	0 to 250°F
Maximum Pressure	175 PSI
pH Limitations	7.0 - 9.0
Material	Braided Graphite Impregnated PTFE

\* For operating temperatures above 250°F a cooled flush is required and is recommended for temperatures above 225°F for optimum seal life. On closed systems cooling is accomplished by inserting a small heat-exchanger in the flush line to cool the seal flushing fluid.

Flush-line Filters and Sediment Separators are available on special request.

## Materials of Construction

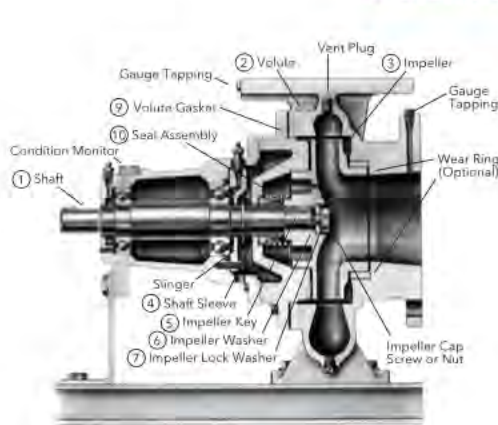

Standard Configuration

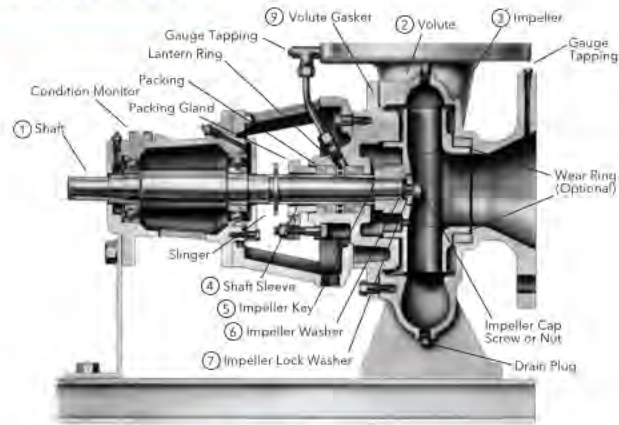

Optional - S Configuration

Description	SM, LG, & XL Bearing Frames	ES Bearing Frame
1 Shaft	ASTM 108 Grade 1144	ASTM 108 Grade 1144
2 Volute	Cast Iron ASTM A48 Class 30B	Cast Iron ASTM A48 Class 30B
3 Impeller	ASTM A743 Grade CF8 - 304 Stainless Steel	ASTM A743 Grade CF8 - 304 Stainless Steel
4 Shaft Sleeve	ASTM 312 Grade TP304 - 304 Stainless Steel	ASTM 312 Grade TP304 - 304 Stainless Steel
5 Impeller Key	#304 Stainless Steel	NA
6 Impeller Washer	Steel	NA
7 Impeller Lock Washer	#304 Stainless Steel (18-8 XL FRM)	NA
8 Impeller Cap Screw	#304 Stainless Steel	NA
8 Impeller Nut	NA	316 Stainless Steel
9 Volute Gasket	Cellulose Fiber	Cellulose Fiber
10 Seal Assembly	Reference Seal Data Tables	Reference Seal Data Tables

## Pump Options

- Stainless Steel Volute Wear Ring
- Galvanized Steel Drip Pan
- Stainless Steel Shaft
- Rexnord Omega Spacer Coupling
- Falk T31 Spacer Coupling
- External Flush Line
- Stuffing Box Configuration
- Epoxy Coated Internal Cast Iron Components
- Special Impeller Balancing (ISO 1940 G2.5 or G1.0)
- Certified Performance Tests (Per HI Standard 14.6)
- 250 PSI Working Pressure



<b>Job/Project:</b>	<b>Representative: Wallace Eannace Associates</b>		
<b>ESP-Systemwize: WIZE-7816F72F</b>	<b>Created On: 06/23/2023</b>	<b>Phone: (516) 454-9300</b>	
<b>Location/Tag:</b>	<b>Email: info-ny@wea-inc.com</b>		
<b>Engineer:</b>	<b>Submitted By:</b>	<b>Date:</b>	
<b>Contractor:</b>	<b>Approved By:</b>	<b>Date:</b>	

### Base Mounted End Suction Pump

**Series: e-1510**

**Model: 1.25BC**

#### Features & Design

- ANSI/OSHA Coupling Guard
- Center Drop Out Spacer Coupling
- Fabricated Heavy Duty Baseplate
- Internally Self-Flushing Mechanical Seal



\*The Bell & Gossett Series e-1510 is available in 26 sizes and a variety of configuration options that enable customization and flexibility to fit a broad range of operating conditions.

<http://bellgossett.com/pumps-circulators/end-suction-pumps/e-1510/>

### Pump Selection Summary

Duty Point Flow	72 US gpm
Duty Point Head	292.5 ft
Control Head	87.75 ft
Duty Point Pump Efficiency	47.8 %
Part Load Efficiency Value (PLEV)	40.4 %
Impeller Diameter	8.25 in
Motor Power	20 hp
Duty Point Power	11.1 bhp
Motor Speed	3600 rpm
RPM @ Duty Point	3495 rpm
NPSHr	11.6 ft
Minimum Shutoff Head	303 ft
Minimum Flow at RPM	28.1 US gpm
Flow @ BEP	141 US gpm
Fluid Temperature	70 °F
Fluid Type	Water
Weight (approx. - consult rep for exact)	448 lbs
Pump Floor Space Calculation	5.42 ft <sup>2</sup>

### Performance Curve

#### Energy Efficiency Ratings:

Pump & Motor PEIcI: 0.8 ERcI: 20  
Pump, Motor & Drive: PEIvI: 0.41 ERvI: 59



**e-1510**  
**1.25BC**  
**3495 RPM**

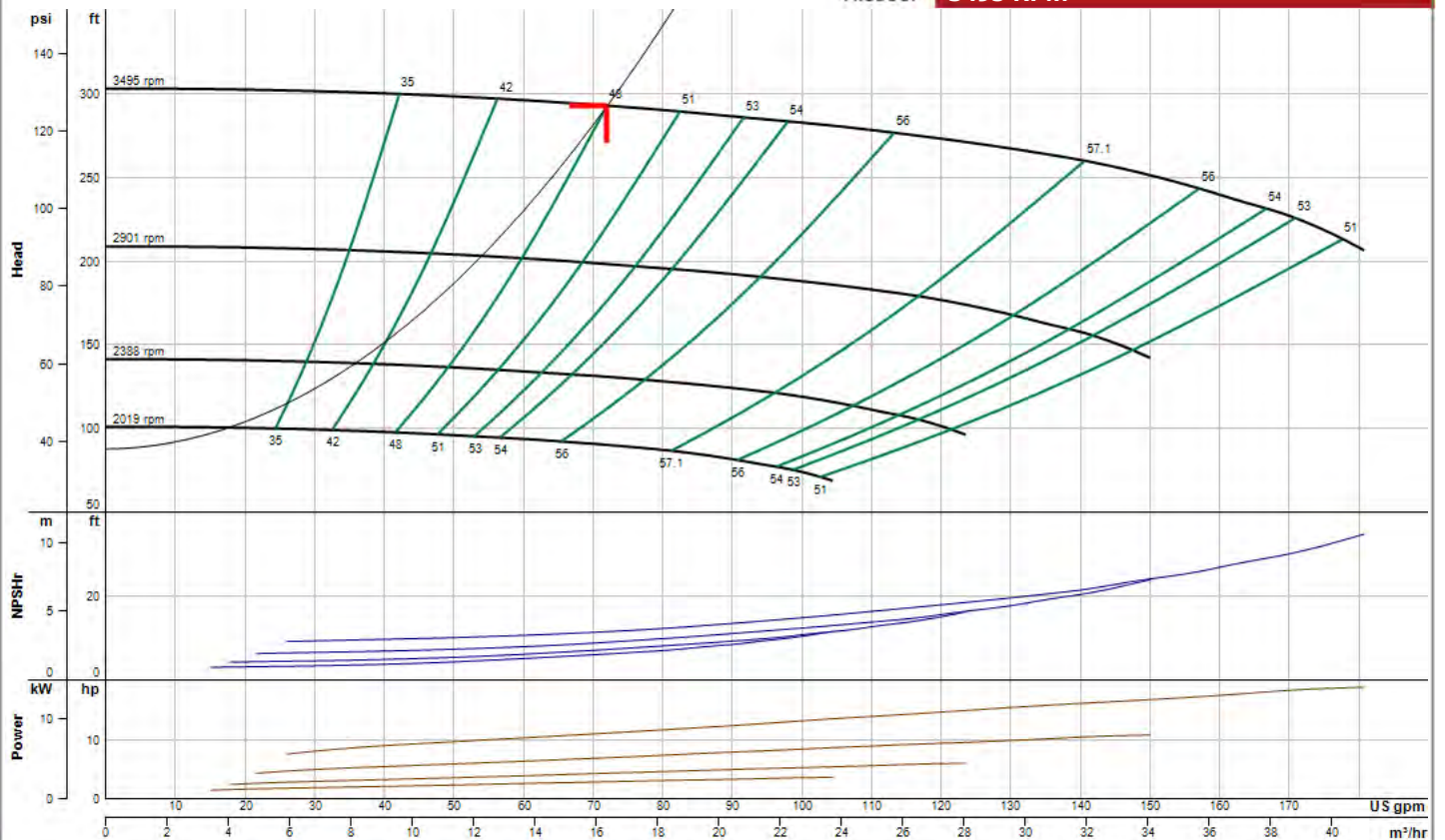



# Constant Speed Curve (3525 rpm)

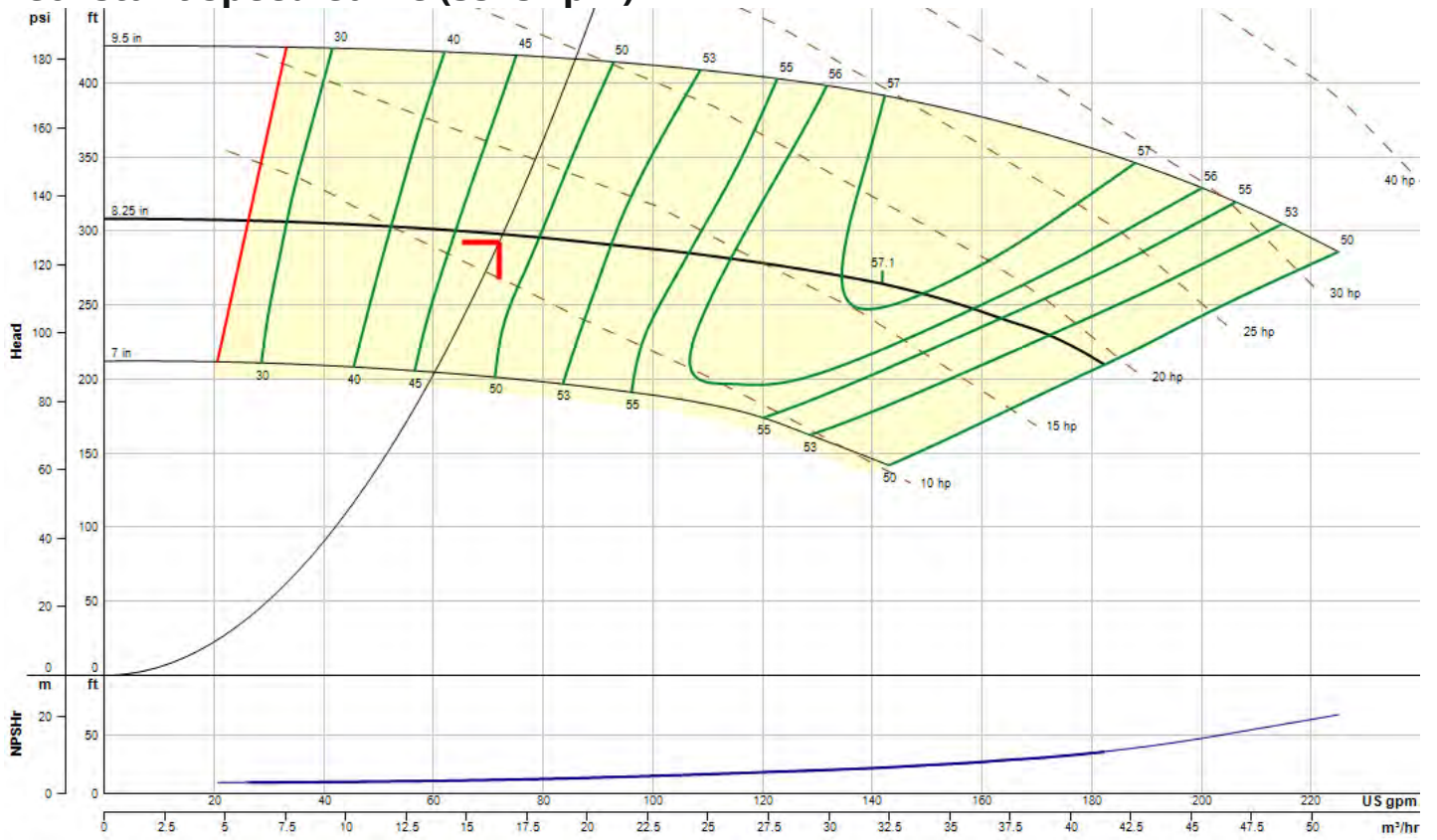

## Operating Point

**Flow:** 72 US gpm **Head:** 293 ft **Speed:** 3495 **Efficiency:** 47.8% **Point BHP:** 11.1 **End Of Curve:** 39.9%

## Maximum Duty Point (at rated motor speed)

**Flow:** 72.6 US gpm **Head:** 298 ft **Speed:** 3525 **Efficiency:** 47.8% **Point BHP:** 11.4 **NOL Flow:** 182 US gpm **Runout Flow:** 182 US gpm **NOL (BHP):** 19.3

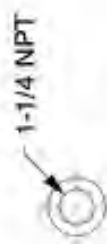

1-1/4 NPT DISCHARGE DETAILS

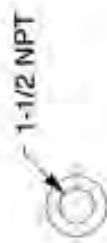

1-1/2 NPT SUCTION DETAILS

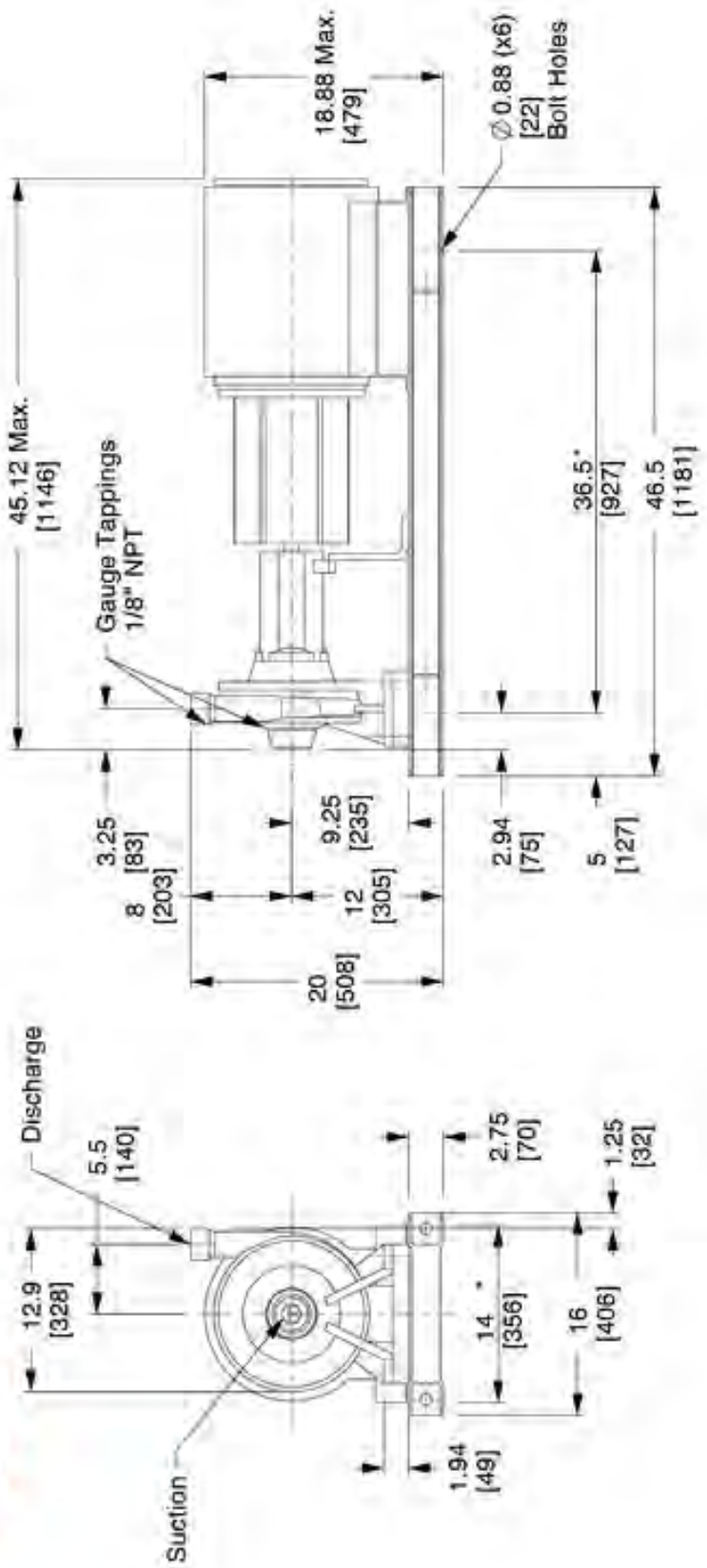

\* Dist. Between Bolt Holes



a xylem brand  
8200 N. Austin Ave.  
Morton Grove, IL 60053, USA

This drawing and the information depicted therein is the property of Xylem. Copies are issued in strict confidence and shall not be reproduced or copied, or used as the basis for the manufacture or sale of products without prior written permission of Xylem. Dimensions are subject to change. Not to be used for construction unless certified

**BG-E1510-1P25BC-SS-254T-L**

Series e-1510 Centrifugal Pumps - Base Mounted  
Seal Type: Standard Seal | Motor Frame: 254T | Frame Type-L

Dimensions : IN (mm) | Scale : N.T.S. | Submittal # : B-880.14B

## Standard Mechanical Configuration

Standard Mechanical Seal	SM, LG, & XL Bearing Frames	ES Bearing Frame
Temperature Range	-20 to 225°F	-20 to 225°F
Maximum Pressure	175 PSI	175 PSI
pH Limitations	7.0 - 9.0	7.0 - 9.0
Elastomer	Buna	Buna
Rotating Face	Carbon	Carbon
Stationary Face	Ceramic	Silicon Carbide
Hardware	Stainless Steel / Brass	Stainless Steel

Mechanical Seal Options	SM, LG, & XL Bearing Frames		
Temperature Range	-20 to 250°F	-10 to 225°F	-20 to 250°F
Maximum Pressure	175 PSI	175 PSI	175 PSI
pH Limitations	7.0 - 11.0	7.0 - 9.0	7.0 - 12.5.0
Elastomer	EPR (Ethylene Propylene Rubber)	FKM (Viton™ or Fluoroelastomer)	EPR (Ethylene Propylene Rubber)
Rotating Face	Carbon	Carbon	Silicon Carbide
Stationary Face	Tungsten Carbide	Ceramic	Silicon Carbide
Hardware	Stainless Steel / Brass	Stainless Steel	Stainless Steel

Mechanical Seal Options	ES Bearing Frame		
Temperature Range	-20 to 250°F	-10 to 225°F	-20 to 250°F
Maximum Pressure	175 PSI	175 PSI	175 PSI
pH Limitations	7.0 - 11.0	7.0 - 9.0	7.0 - 12.5.0
Elastomer	EPR (Ethylene Propylene Rubber)	FKM (Viton™ or Fluoroelastomer)	EPR (Ethylene Propylene Rubber)
Rotating Face	Silicon Carbide	Carbon	Silicon Carbide
Stationary Face	Tungsten Carbide	Silicon Carbide	Silicon Carbide
Hardware	Stainless Steel / Brass	Stainless Steel	Stainless Steel

## Stuffing Box Configuration

Mechanical Seal	SM, LG, & XL Bearing Frames
Temperature Range	-20 to 250°F*
Maximum Pressure	175 PSI (Optional 250 PSI)
pH Limitations	7.0 - 11.0
Elastomer	EPR (Ethylene Propylene Rubber)
Rotating Face	Tungsten Carbide
Stationary Face	Carbon
Hardware	Stainless Steel

Packing Option	
Temperature Range	0 to 250°F
Maximum Pressure	175 PSI
pH Limitations	7.0 - 9.0
Material	Braided Graphite Impregnated PTFE

\* For operating temperatures above 250°F a cooled flush is required and is recommended for temperatures above 225°F for optimum seal life. On closed systems cooling is accomplished by inserting a small heat-exchanger in the flush line to cool the seal flushing fluid.

Flush-line Filters and Sediment Separators are available on special request.

## Materials of Construction

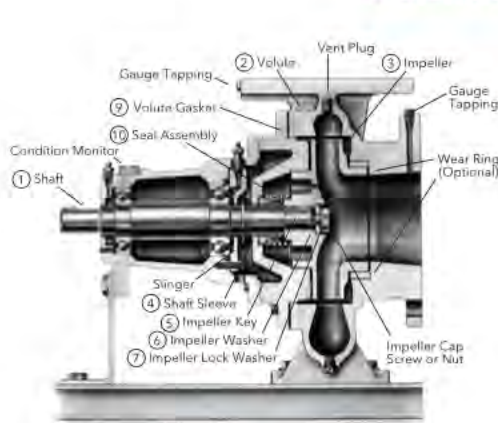

Standard Configuration

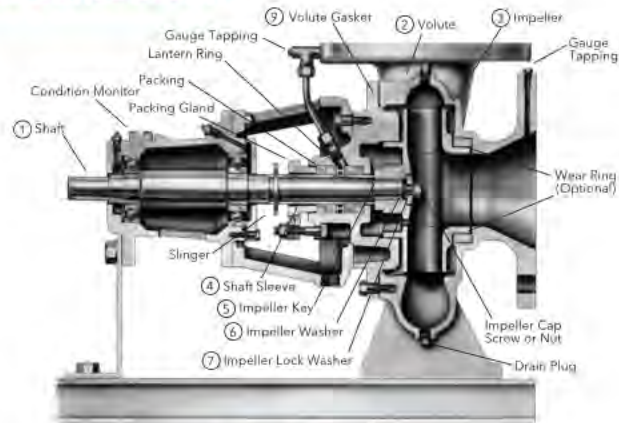

Optional - S Configuration

Description	SM, LG, & XL Bearing Frames	ES Bearing Frame
1 Shaft	ASTM 108 Grade 1144	ASTM 108 Grade 1144
2 Volute	Cast Iron ASTM A48 Class 30B	Cast Iron ASTM A48 Class 30B
3 Impeller	ASTM A743 Grade CF8 - 304 Stainless Steel	ASTM A743 Grade CF8 - 304 Stainless Steel
4 Shaft Sleeve	ASTM 312 Grade TP304 - 304 Stainless Steel	ASTM 312 Grade TP304 - 304 Stainless Steel
5 Impeller Key	#304 Stainless Steel	NA
6 Impeller Washer	Steel	NA
7 Impeller Lock Washer	#304 Stainless Steel (18-8 XL FRM)	NA
8 Impeller Cap Screw	#304 Stainless Steel	NA
8 Impeller Nut	NA	316 Stainless Steel
9 Volute Gasket	Cellulose Fiber	Cellulose Fiber
10 Seal Assembly	Reference Seal Data Tables	Reference Seal Data Tables

## Pump Options

- Stainless Steel Volute Wear Ring
- Galvanized Steel Drip Pan
- Stainless Steel Shaft
- Rexnord Omega Spacer Coupling
- Falk T31 Spacer Coupling
- External Flush Line
- Stuffing Box Configuration
- Epoxy Coated Internal Cast Iron Components
- Special Impeller Balancing (ISO 1940 G2.5 or G1.0)
- Certified Performance Tests (Per HI Standard 14.6)
- 250 PSI Working Pressure





Product Catalog

# Water Source Heat Pump Axiom™ High Efficiency Console — GEC

0.5 to 1.5 Tons — 50/60 Hz







## Introduction

The Trane® Axiom™ (model GEC) water-source comfort system features a sloped top design providing both fundamental performance requirements, exceptional quality, sound attenuation and ease of maintenance.

Other features include:

- Dual sloped polymer drain pan
- Hot gas reheat (option)
- Electric heat (option)
- Motorized 25% outside-air (option)
- Field adjustable supply-air grille
- Integrated controls
- Quiet unit design
- Panel free filter maintenance
- High and low pressure switches as standard
- Compact size

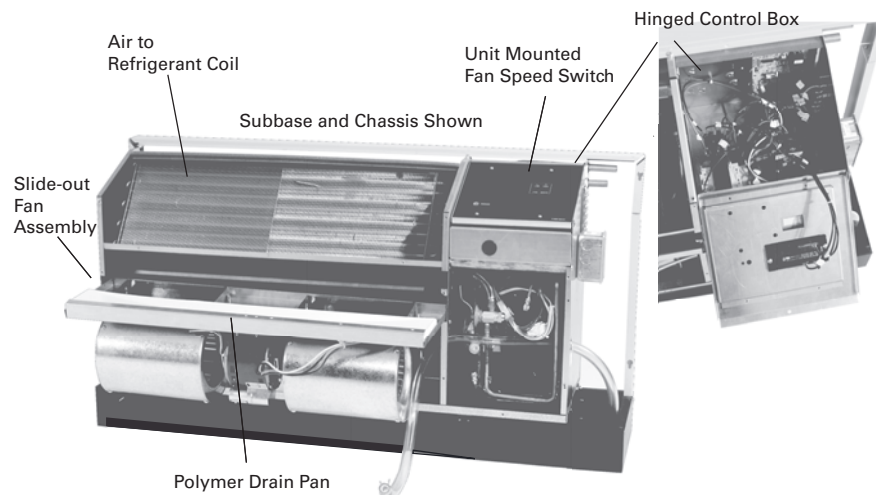

## Copyright

This document and the information in it are the property of Trane, and may not be used or reproduced in whole or in part without written permission. Trane reserves the right to revise this publication at any time, and to make changes to its content without obligation to notify any person of such revision or change.

## Trademarks

All trademarks referenced in this document are the trademarks of their respective owners.

## Revision History

- Updated the term Symbio™ 400-B throughout the document.
- Removed Tracer® ZN524 topic in Controls chapter.
- Updated Model Number Description chapter.
- Updated Electrical Data and Thermostats and Zone Sensors chapter.



# Table of Contents

Introduction	2
Features and Benefits	4
Design	4
Cabinet	4
Field Flexibility	5
Right Hand Piping	5
Left Hand Piping	5
Sound Data	11
Application Considerations	14
Geothermal System	14
Central Pumping for the GEC Product	15
Installation Considerations	16
Selection Procedure	18
Cooling Dominated Applications	18
Heating Dominated Applications	18
Model Number Description	19
General Data	20
Performance Data	21
Examples	38
Electrical Data	40
Unit Dimensions	42
Service Clearances	42
Controls	54
Deluxe 24V Controls	54
Stand-alone System	54
Deluxe 24V electronic controls include:	54
Deluxe 24V features	55
Tracer® Symbio™ 400-B/UC400-B	56
Tracer Symbio 400-B/UC400-B functions include:	56
Trane® Air-Fi® Wireless Systems	59
Thermostats and Zone Sensors	61
Mechanical Specifications	64
Electrical	64



# Features and Benefits

## Design

The console configuration features a tri-building block design and includes the cabinet, chassis and subbase.



These building blocks may be ordered in several configurations. They include:

- Standard configuration (cabinet, chassis, and subbase)
- Low height configuration (chassis, cabinet, and short subbase)
- Extended length (cabinet, chassis, and subbase)
- Chassis ONLY

The console configuration model GEC product offers a range of capacities 0.5 to 1.5 tons supporting multiple application requirements in the commercial conditioning industry. This includes:

- Hotel rooms
- Offices
- Condominiums
- Assisted living facilities
- Dormitories

## Cabinet

The cabinet is constructed of heavy gauge metal for maximum durability. The cabinet finish is pre-painted and available in deluxe beige, cameo white, and soft dove.

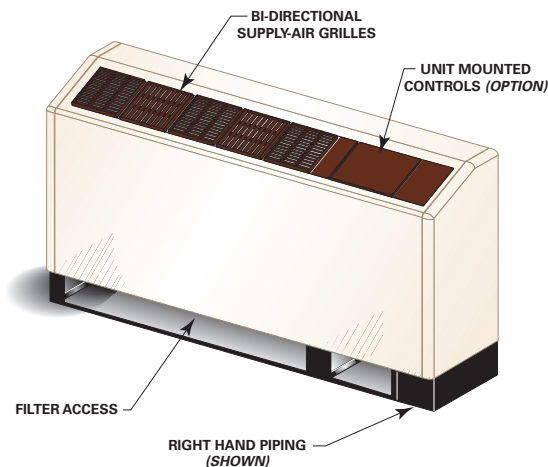

The cabinet design includes a hook-secure fit that allows complete access to piping and electrical hook-up for ease of maintenance and serviceability. The single cabinet assembly is securely fastened into the wall sleeve with four 5/16-inch bolts.

### Field Flexibility

Piping and electrical connections to the console are made in either the left or right hand end pocket. The unit refrigeration platform and the unit control box is maintained in the same location whether left or right hand piping, standard unit cabinet, extended unit cabinet, or low height unit cabinet has been specified. This cloned platform poses a common look and feel to the installer, as well as aids in troubleshooting during service or maintenance check-ups.

### Right Hand Piping

Console units ordered with a right hand piping connection have the end pocket located on the right hand side of the unit. This end pocket provides room for connecting field supply, return, and condensate piping to the unit. It also provides space for the high and low voltage connections.

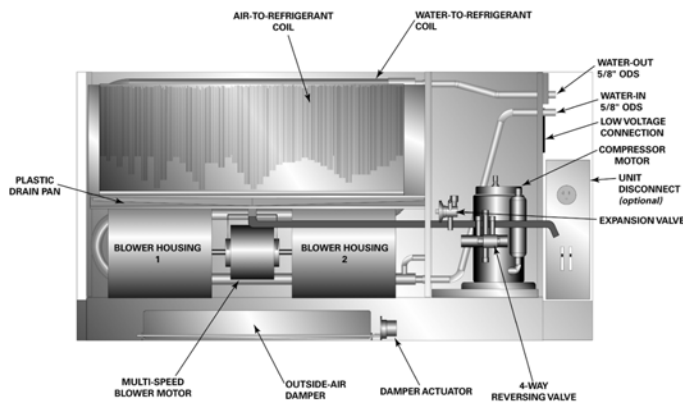

### Left Hand Piping

Console units ordered with a left hand piping connection have the end pocket located on the left hand side of the unit. This end pocket provides room for the field supply, return, and condensate piping connection to the unit. Installation for the high voltage connection is also made in the left hand end pocket. Installing the low voltage controls (thermostat/sensor hook-up) is ALWAYS made on the right hand side of the unit. The low voltage termination for thermostat or sensor wires may be run along the back side of the chassis to the right hand side of the unit for connection.

**Note:** Units containing the unit mounted control option will ship from the factory pre-wired. No low voltage hook-up is required.

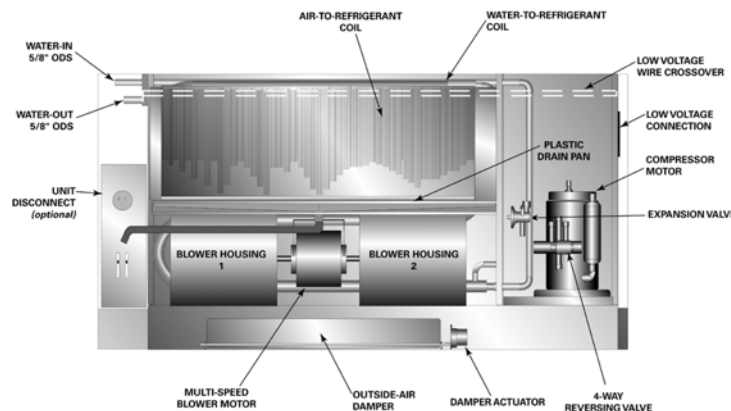



## Features and Benefits

**Figure 1. Air-side filter**

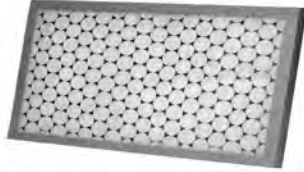

The air-side filtration option includes a 1-inch pleated filter. The filter includes an average synthetic dust weight arrestance of approximately 75%. This dust holding capability includes a colorless, odorless adhesive to retain dirt particles within the filter media after fiber contact.

### Air-to-Refrigerant Coil

The air-to-refrigerant heat exchanger is constructed of staggered copper tubes with die-formed corrugated lanced aluminum fins. The fins are then mechanically bonded to the tubes through expansion.

The maximum working pressure of the coil is 650 psig. It is designed for maximum capacity with an additional benefit of physical unit size reduction.

Coil specifications for the GEC unit are in the following table.

**Table 1. GEC coil specifications**

Unit Size	# of Rows	Fins/inch
006, 009, 015, 018	3	14
012	2	14

**Figure 2. Blower housing**



The blower housing is constructed of non-corrosive galvanized steel. Serviceability to the housing is made through the chassis air-side front panel. The fan housing is mounted onto a fan board assembly which also includes the fan wheel, and fan motor. This fan board assembly may be easily removed from the chassis by sliding the fan board forward in maintenance or service situations.

**Figure 3. Blower motor**



The supply-air (blower) motor is a multi-speed motor with internal thermal overload protection. The motor bearings are permanently lubricated and sealed. Standard motors are rated from 220 CFM at low speed (unit size 006) to 530 CFM at high speed (unit size 018).

All motors are factory wired for low and high speed options. Switching for speed control is located in the unit control panel. See fan performance section for factory ratings of low and high speed settings.

### Boilerless Control, Electric Heat System (option)

The boilerless electric heat option is composed of a nichrome open wire heating element with an internal temperature limit placed above the fan housing and an electronic (boilerless) controller located in the main control box.

The boilerless control option is comprised of a single stage of electric heat and is designed to invoice electric heat in the event that entering-water temperatures falls below 55°F. On a call for heating, the electric heater is energized, locking out the compressor. Once the entering water temperature rises, above

60°F, the boilerless controller returns the unit to normal compressor heating operation and locks out the electric heater.

For geothermal applications, the boilerless controller has an adjustable setting of 25°, 35°, 45°, 55° and 60°.

This option is available with deluxe, Symbio™ 400-B/Tracer® UC400-B, control package.

**Figure 4. Boilerless control electric heat schematic**

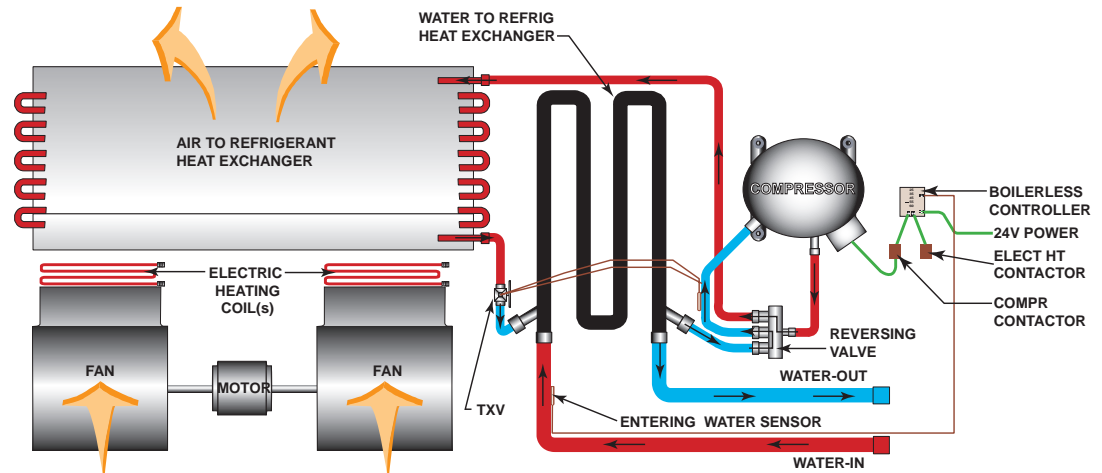

**Table 2. Heating elements**

Unit Size	Voltage	# of Elements	kW	Heater Total Amps	Digit 22
006	208	1	2.25	10.82	2 (minimum)
006	208	1	3.00	14.42	3 (maximum)
006	230	1	3.00	12.50	2 (minimum)*
006	265	1	3.00	10.83	2 (minimum)*
009-018	208	2	2.25	10.82	2 (minimum)
009-018	208	2	3.00	14.42	3 (maximum)
009-018	230	2	3.00	12.50	2 (minimum)
009-018	230	2	4.00	16.67	3 (maximum)
009-018	265	2	3.00	10.83	2 (minimum)
009-018	265	2	4.00	14.44	3 (maximum)

**Note:** \* For size 006, only 3 kw is offered for 230V and 265V.

### Cabinet Insulation

The cabinet insulation design meets UL 181 requirements. The air stream surface of the insulation is fabricated of a non-biodegradable source.

The insulation in the wet section of the cabinet complies with ASHRAE standard 62 to accommodate (IAQ) indoor air quality standards.

## Features and Benefits

---

**Figure 5. Co-axial coil**



The unit's internal heat exchanging water coil is engineered for maximum heat transfer.

The copper or cupro-nickel seamless tubing is a tube within a tube design. The inner-tube contains a deep fluted curve to enhance heat transfer and minimize fouling and scaling. Co-axial heat exchangers are more tolerant to freeze rupture.

**Figure 6. Compressor**



The unit's design includes a rotary compressor motor in dedicated voltages and tonnage sizes to aid in voltage variations along with noise reduction of the unit.

As an added benefit, Trane double isolates the compressor and the mounting plate assembly in the unit to reduce sound vibration during compressor operation.

### Compressor and Co-axial Coil Isolation

Vibration isolation for the compressor and co-axial water coil is accomplished by increasing the rigidity and stiffness at the base for the compressor, and at the back of the chassis for the co-axial water coil. This platform includes double isolation to the compressor and single isolation to the co-axial water coil.

**Figure 7. Crankcase heater**



The crankcase heater is a sealed heater installed with close contact to the outer circumference at the bottom of the compressor.

The purpose of installing this device is to protect the compressor from the negative effects of liquid refrigerant confinement.

**Figure 8. Drain pan**



The unit drain pan is composed of a polymer, corrosive resistive material. The pan is positively sloped to comply with ASHRAE 62 for (IAQ) indoor air quality conformity.

Access to the drain pan is provided through the front chassis access panel. The drain pan is removable for cleaning.

**Figure 9. Expansion valve**



The refrigerant flow metering is made through the thermal expansion valve (TXV). It allows the unit to operate with an entering fluid temperature from 25°F to 120°F and entering air temperatures from 50°F to 95°F. The valve is designed to meter refrigerant flow through the circuitry to achieve desired heating or cooling.

Unlike cap-tube assemblies, the expansion valve device allows the exact amount of refrigerant required to meet the coil load demands. This precise metering by the TXV increases the efficiency of the unit.

**Figure 10. Filter drier**



The filter drier is a solid core, bi-directional, liquid line filter drier for heat pump applications. Internal check valves allow flow and filtration in either direction.

With high moisture and acid removal capacity, the filter drier prevents the system from the damage of water and impurity within the refrigerant.

**Figure 11. Hinged control box**



Controls for the console unit are housed on the right-hand side of the chassis. The box dwells above the refrigeration section of the chassis.

Access to the controls are made by way of a hinged control box. This hinged box allows easy access for service and installation of the controls portion of the chassis.

### Hot Gas Reheat (option)

For true atmospheric conditioning and climate control, Trane provides accurate, cost effective dehumidification control through a hot gas reheat option.

With this reheat option, the return air from the space is cooled by the air-to-refrigerant coil, then reheated by the reheat coil to control not only space temperature, but to also reduce the relative humidity of the space. The amount of moisture removal of a specific heat pump is determined by the unit's latent capacity rating.

When operating in the reheat mode, the humidistat signals the reheat relay coil to energize, allowing the high pressure refrigerant gas to flow from the compressor, through the reversing valve, into the reheat valve, for passage through the reheat coil.

**Note:** The hot gas reheat option is available with Deluxe, Symbio 400-B/UC400-B control package.



### Common Reheat Applications

- Conditioned-air delivered directly to the space.
- Auditoriums, theaters, classrooms or where a large latent load exists.
- Computer room space conditioning.
- Anywhere humidity control is a problem.

Figure 12. Hot gas reheat

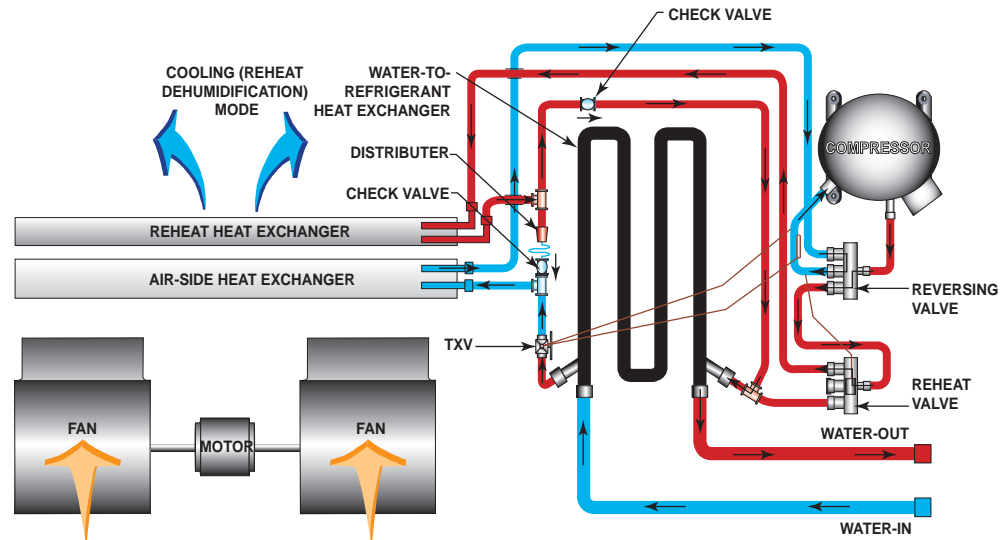

Figure 13. Pump module



The pump module and hose kit make a complete self-contained pumping package for distributed pumping systems. These kits contain all the necessary components for the installation, operation and maintenance of the water circuit of a closed loop geothermal application. Standard pump module features include insulated Grundfos pumps, insulated cabinet, cast iron pump, and 3-way brass valves. Literature number WSHP-SVN001\*-EN will provide electrical and dimensional requirements for the PMCA products.

Figure 14. Pump module hose kit



The pump module hose kit consists of two brass, 3/4 in. or 1 in., external pipe thread (MPT)-by-barb fittings; two brass 90° 1-inch, MPT-by-barb elbows with pressure/temperature ports; and 10 ft of rubber hose with 4 hose clamps. The pump module hose kit is available separately from the pump module.

### Refrigerant Piping

The unit's copper tubing is created from a 99% pure copper formation that conforms to the American Society of Testing (ASTM) B743 for seamless, light-annealed processing.

The unit's copper refrigeration system is designed to be free from contaminants and conditions such as drilling fragments, dirt, or oil. This excludes the possibility of these contaminants from damaging the compressor motor.

**Figure 15. Reversing valve**



A system reversing valve (4-way valve) is included with all heating/ cooling units. This valve is piped to be energized in the cooling mode to allow the system to provide heat if valve failure were to occur. Once the valve is energized for cooling, it will remain energized until the control system is turned to the OFF position, or a heating cycle is initiated.

### Schrader Connections

The refrigerant access ports shall be factory supplied on the high and low pressure sides for easy refrigerant pressure or temperature testing.

### Supply-Air Registers

Supply-air registers for the GEC product are constructed of a polymer, corrosive resistive material. The registers include a snap-in deflection design to simplify installation, as well as facilitate the ability to apply a bi-directional arrangement across the register

**Figure 16. Wall sleeve**

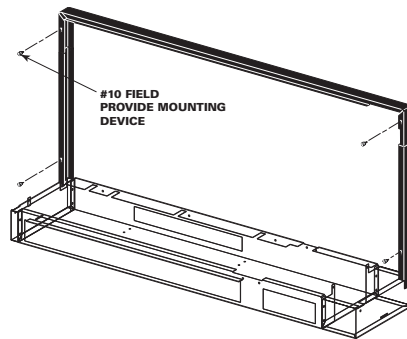

The cabinets wall sleeve is attached to the wall by (4) four, #10 field provided screws. This rigid design allows for ease of separation from the cabinet assembly during service or installation situations.

The wall sleeve is painted the same color as the cabinet for aesthetic purposes.

## Sound Data

### Sound Attenuation Package

The console equipment is designed to achieve the lowest noise levels possible. Extensive testing has identified the major sound generating sources within the console unit package. Every effort has been made to minimize the sound generation and transmission from the compressor, heat exchangers, and fan sources. Vibration transmission from the compressor and heat exchangers have been minimized by the use of isolation. The use of heavy metal gauges in critical areas enhance the unit acoustic performance. A patented two-stage compressor isolation system has been specifically designed for the console unit. Acoustic lining has been used to quiet compressor noise.

The unit air side acoustic performance has been engineered to obtain the quietest acoustic performance through the fan, and fan housing selection. The fin tube (air-to-refrigerant) coil and fan discharge arrangement includes an additional acoustic lining in the fan compartment to further reduce the air side sound levels.

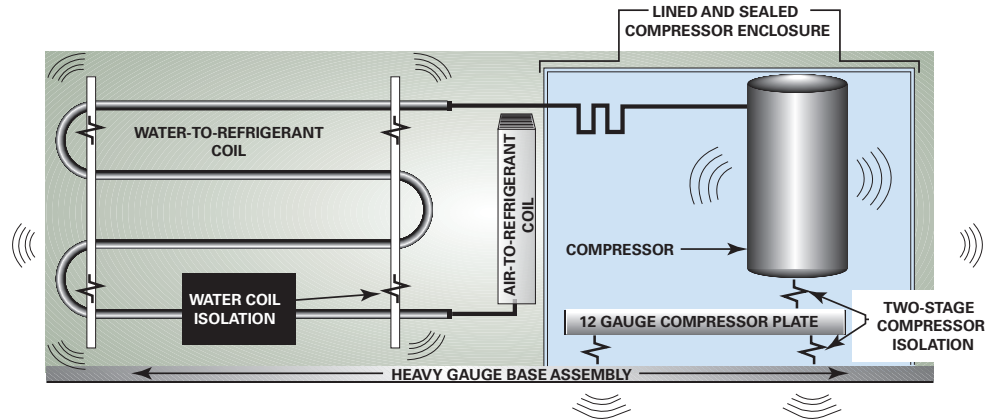
**Figure 17. Console noise control**

The standard unit sound package for the console unit includes:

- Two stage compressor vibration isolation
- Water-to-refrigerant heat exchanger vibration isolation
- 12-gauge intermediate mounting plate for the compressor
- Lined compressor enclosure with ½-inch cabinet insulation
- Heavy gauge base assembly
- Maximum sized return-air opening and filter sizing

To ensure consistent performance, an extensive series of tests were conducted on each cabinet size.

- Sound power testing per AHRI's standard 350 for non-ducted air handling equipment (*a noise evaluation to quantify the strength of various sound components for application in building system design*). These include:

GEC:            Inlet+Casing  
                      Discharge

For unit specific octave band sound power data, please refer to the TOPPS selection program.

### What is Sound Pressure?

Sound pressure is a pressure disturbance in the atmosphere whose intensity is influenced not only by the strength of the source, but also by the surroundings and the distance from the source to the receiver. Sound pressure is what our ears hear, and what sound meters measure. The level of sound pressure, or the *loudness* of a given noise source, depends on three factors:

1. The strength of the source
2. The environment in which the source is located
3. The listener's distance from the source

As an example, of the effect of environment, consider the sound produced by a drum. The drum is perceived to be louder in a bathroom with hard tile walls than it is in the middle of a football field. Also, the farther one moves away from the drum, the quieter it sounds. In each case, the vibration of the drum (the strength of the source) is the same; the perceived differences in noise level are due to the environment.

Because of the extremely wide range of sound pressure perceivable by a person—typically five or six order of magnitude—it is convenient to express sound pressure on a logarithmic scale. As a result, adding

two equal sound sources together will result in an overall increase of 3 dB. However, 3 dB is barely a perceptible increase in sound. It takes an increase of 10 dB to be perceived as twice as loud.

### What is Sound Power?

Sound power is a measure of the acoustical energy emitted from a sound source, and is an absolute value. As discussed above, our hearing does not perceive sound power directly, as there is always some environmental medium between the source and the listener. However, from the standpoint of a building designer, sound power is often the preferred means of quantifying the noise of a given unit because it is a certifiable quantity. Using predictions are used to tailor the design to the sound pressure level requirements of the building. The environmental effects that must be taken into account when converting sound power to sound pressure for a specific location can be lumped together and called the transfer function.

Sound power should always be used when making unit-to-unit sound comparisons because it is a certifiable absolute measure of the sound energy produced by the unit. In contrast, sound pressure is not certifiable because it is difficult to ensure that each manufacturer tests in precisely the same environment. As in the case of sound pressure, it is useful to express sound power on a logarithmic scale.

### What are NC and dBA?

Both NC and dBA are single number descriptors used to represent perceived loudness. Both scales take into account the fact that people are more sensitive to high frequencies than they are to low frequencies.

Noise Criterion (NC) is widely used to quantify indoor sound. The NC level is determined by the strength of sound pressure across the 63 Hz to 8000 Hz frequency range.

“A” weighted sound (dBA) is a single number descriptor often used to define sound in outdoor environments. For example, local sound ordinances typically regulate dBA levels at property lines. hearing-related safety standards written by such bodies as the Occupational Safety and Health Organization (OSHA) also commonly refer to A-weighted sound readings.

As a rule, “A” weighting is applied to octave-band sound pressure data. Applying “A” weighting sound power is only appropriate in accordance with AHRI 270. While NC and dBA are the most popular, other single number descriptors for sound are available including Room Criterion (RC), NCB and other weightings.

**Figure 18. Octave band center of frequency**

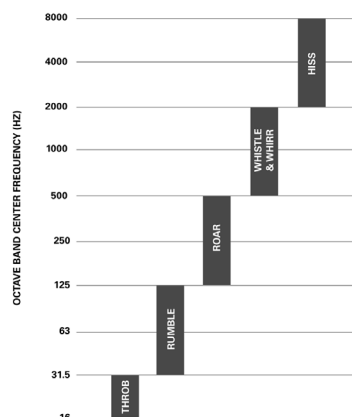



# Application Considerations

## Geothermal System

Closed-loop systems (both ground source and surface water) provide heat rejection and heat addition to maintain proper water-source temperatures. The choice of vertical, horizontal, or lake loop earth coupling, should be based on the characteristics of each application.

Horizontal and vertical systems can be designed to provide the same fluid temperatures under a given set of conditions. The surface (lake) loop system may see a greater variance of fluid temperatures, but the reduced installation cost may compensate for any minor reduction in performance. The three earth coupling methods should be considered at each application, with the most cost effective method chosen after all have been evaluated.

Operating and maintenance cost are low because an auxiliary electric/fossil fuel boiler and cooling tower are not required to maintain the loop temperature in a properly designed system.

The technology has advanced to the point where many electric utilities and rural electric cooperatives are offering incentives for the installation of geothermal systems. These incentives are offered because of savings to the utilities due to reduced peak loads and flatten out the system demand curve over time.

When building cooling requirements cause loop water temperatures to rise, heat is absorbed into the cooler earth through buried high density polyethylene pipe heat exchangers in a ground source geothermal system. If reversed, heating demands cause the loop temperature to fall, enabling the earth to add heat to meet load requirements.

Where local building codes require water retention ponds for short term storage of surface run-off, a ground source surface water system can be very cost effective. This system has all the advantages of the geothermal system in cooling dominated structures.

Another benefit of the ground source system is that it is environmentally friendly. The loop is made of chemically inert, non-polluting, polyethylene pipe. The heat pumps use R-410A refrigerant, which has a negligible ozone depletion potential. Because the closed-loop system does not require a heat adder, there are no local CO<sub>2</sub> emissions. Less electric power is consumed by the system, thereby reducing secondary emissions from the power plant. Therefore, the system offers advantages not seen by other HVAC system types.

**Figure 19. Geothermal systems**

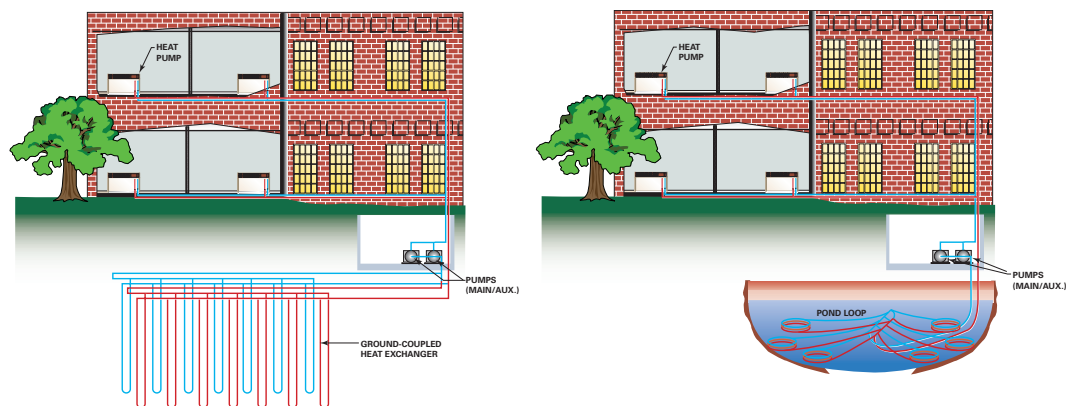

## Open-Loop System

Where an existing or proposed well can provide an ample supply of suitable quality water, ground water systems may be very efficient.

Operation and benefits are similar to those for closed-loop systems. There are, however, several considerations that should be addressed prior to installation.

An acceptable way to discharge the significant volume of used water from the heat pump should be defined. It may be necessary to install a recharge well to return the water to the aquifer.

Water quality must be acceptable, with minimal suspended solids and proper pH. To help ensure clean water, a straining device may be required.

### Cooling Tower/Boiler System

A cooling tower/boiler system (utilizes a closed-water loop along with multiple water-source heat pumps in a more conventional manner.

Typically, a boiler is employed to maintain closed loop temperatures above 60°F and a cooling tower to maintain closed loop temperature below 90°F. All the units function independently, either by adding heat, or removing heat from a common closed water loop. Because the heat from a building is being rejected through a cooling tower, the system is more efficient than air cooled system.

The cooling tower/boiler system provides a low installation cost to the owner when compared to other systems and is the most common application. It also allows the owner to add units to the condenser water loop as needed.

**Figure 20. Geothermal systems**

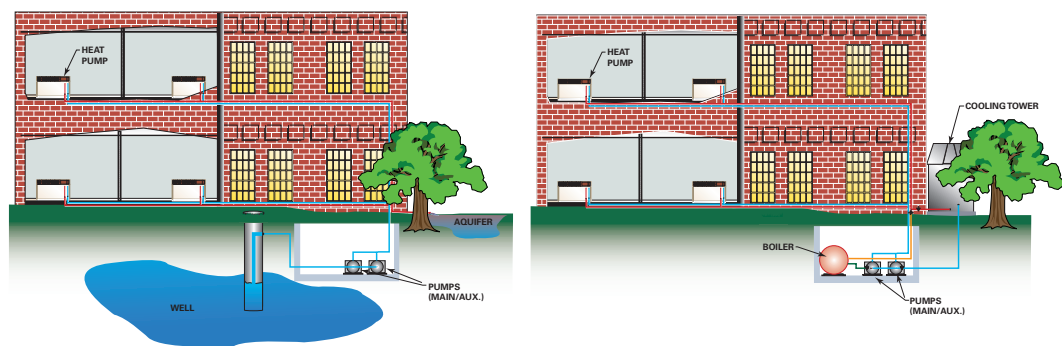

## Central Pumping for the GEC Product

Central pumping systems employ a single or dual pump design to fulfill pumping requirements for the entire building system. Pumps are usually installed downstream of the cooling tower and boiler and upstream of the units to ensure positive water pressure throughout the system. The most common configuration is to use two pumps manifolded together with each pump sized to meet the flow requirements of the entire system. Only one of the pumps operates at any given time, with the second available as “standby” pump in case the operating pump was to fail.

- Hose kits are used to connect the water supply and return line to the water inlets and outlets. Trane offers various hose kit combinations to better facilitate system flow balancing. These flexible hoses also aid in the reduction of vibration between the unit and the rigid central piping system.
- A two position isolation valve is often applied to systems which incorporate variable frequency pumping. This valve is capable of stopping/starting water flow to the unit, which in turn reduces the pumping requirements for the entire system.
- The central system supply and return lines should be sized to handle the required flow with a minimum pressure drop.

**Note:** *Pipe will sweat if low temperature water is below the dew point of the surrounding space. Trane recommends that these lines be insulated to prevent damage from condensation when condenser loop is designed to be below 60°F. Equipment installed in attic/crawl space temperatures below 40°F may require antifreeze in the water loop.*

### Installation Considerations

1. The field supplied line voltage disconnect with circuit breaker should be installed for branch circuit protection.
2. The units high voltage connection is located in the right or left hand end pocket. The field connection may be made to the factory ordered disconnect, or hard wired via the factory mounted 2 x 4 handy box.
3. The low voltage connections are made on the right hand side of the unit for units ordered with the wall mounted thermostat or sensor options. The low voltage connection is factory made if unit mounted controls are specified.
4. Because of the units blow-through design, no condensate trapping is necessary. However, it is necessary for the condensate to run in a downward motion to allow gravity to produce a constant outflow.
5. Hose kits are used to connect the water supply and return lines to the water inlet and outlets. Trane can provide various hose kit combinations to better facilitate system flow balancing. These flexible hoses, reduce vibration between the unit and the rigid piping system. For more information on the types of hose kits Trane recommends, reference WSHP-PRC025\*-EN manual.
6. The console design includes a factory provided wall sleeve to facilitate installation of the unit in it's establishment.
7. The grilles are made of a durable polymer symmetrical design. The design constitutes the ability of a multi-directional supply-air from the units top.

### Filter Replacement (standard height configuration)

Filter replacement is done at the front return-air opening of the console unit. No tools are required for the replacement. The maintenance process is done via a 3-STEP process:

1. Through the return-air opening, slide filter to the back of the console unit.
2. Allow the front edge of the filter to drop to floor level.
3. Pull the filter out of the front opening.

**Note:** REVERSE the cycle to install a new filter.

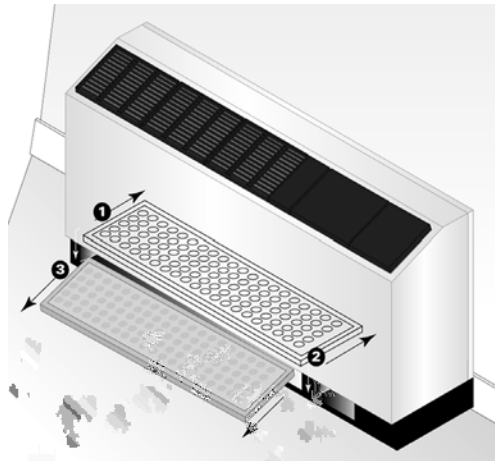

### Filter Replacement (low height configuration)

Filter replacement is done at the front return-air opening of the console unit. A slotted screw driver is needed for the replacement. The maintenance process is done via a 2-STEP process.

1. Insert screw-driver and depress grill tab (2-per grille). Rotate grille down, and lift grille upward to remove grille. The removal of one grille is required.
2. Slide the filter through the grille hole in the cabinet front panel.

**Note:** *REVERSE* the cycle to install a new filter.

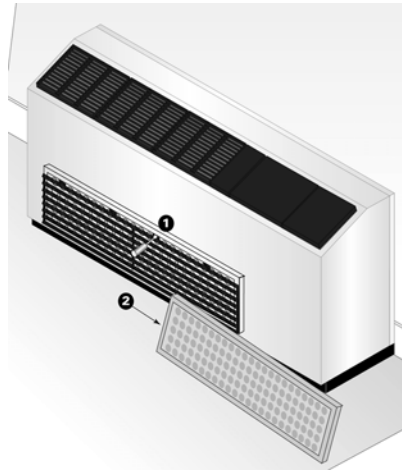





## Selection Procedure

The performance standard AHRI/ISO 13256-1 became effective Jan. 1, 2000. It replaces AHRI standards 320, 325 and 330. This new standard has three major categories: Water Loop (AHRI 320), Ground Water (AHRI 325), Ground Loop (AHRI 330). Although these standards are similar there are some differences.

The cooling efficiency is measured in EER but includes a Watt-per-Watt unit of measure similar to the traditional COP measurement.

The entering water temperature has changed to reflect the centigrade temperature scale. For instance the water loop heating test is performed with 68°F water instead of 70°F. The cooling tests are performed with 80.6°F dry bulb and 66.2°F wet bulb entering air instead of the traditional 80°F dry bulb, and 67°F wet bulb entering air temperatures. This data (80.6/66.2) may be converted to 80/67 by using the entering air correction table.

A pump power correction has been added onto the existing power consumption. Within each model, only one water flow rate is specified for each performance category, and pumping watts are calculated utilizing the pump power correction formula:  $(\text{gpm} \times 0.0631) \times \text{press drop} \times 2990 / 300$ .

**Note:** *gpm relates to water flow, and press drop relates to the drop through the unit heat exchanger at rated water flow in feet of head.*

The fan power is corrected to zero external static pressure. The nominal airflow is rated at a specific external static pressure. This effectively reduces the power consumption of the unit, and increases cooling capacity but decreases heating capacity. These watts are significant enough in most cases to increase EER and COP over AHRI 320, 325, and 330 ratings.

### Cooling Dominated Applications

If humidity levels are moderate to high in a cooling dominated application, the heat pump should be selected to meet or exceed the calculated sensible load. Also, the unit's sensible capacity should be no more than 115% of the total cooling load (sensible + latent), unless the calculated latent load is less than the latent capacity of the unit.

The sensible-to-total cooling ratio can be adjusted with airflow. If the airflow is lowered, the unit latent capacity will increase. When less air is pulled across the DX coil, more moisture will condense from the air.

### Heating Dominated Applications

Unit sizing in heating dominated applications is based upon humidity levels for the climate, and goals for operating cost and installation costs.

If humidity levels are moderate, the heat pump should be selected with the heating capacity equal to 125% of the cooling load.

If humidity levels are low in the application and low operating cost is important, the heat pump and ground loop should be sized for 90% to 100% of the heating load.

If humidity levels are low and lower initial cost is important, then the heat pump and ground loop should be sized for 70% to 85% of the heating load, with the remaining load to be treated with electric resistance heat.

Installation cost will be reduced in this approach because of the smaller heat pump selection and less loop materials.

In general, the system will not use enough electric heat to offset the higher installation costs associated with a fully sized or oversized system.

Finally, a unit sized for the entire heating load in a heating dominated application will be oversized in cooling. Comfort is reduced from increased room humidity caused by short-run times. Short cycling will also shorten the life expectancy of the equipment and increase power consumption and operating cost.

Many rebate incentives require the heat pump and ground loop to be sized for the entire heating load. Check with your local utility for their requirements.



# Model Number Description

## Digits 1-3 — Unit Configuration

GEC = High Efficiency Console

## Digit 4 — Unit Configuration

E

## Digits 5-7 — Nominal Capacity

006 = 0.5 Tons

009 = 0.75 Tons

012 = 1 Tons

015 = 1.25 Tons

018 = 1.5 Tons

## Digit 8 — Voltage Volts/Hz/Phase)

0 = 115/60/1

1 = 208/60/1

2 = 230/60/1

6 = 220-240/50/1

7 = 265/60/1

## Digit 9 — Heat Exchanger

1 = Copper-Water Coil

2 = Cupro-Nickel Water Coil

## Digit 10 — Design Sequence

B

## Digit 11 — Refrigeration Circuit

0 = Heating and Cooling Circuit

2 = Heating and Cooling Circuit with Hot Gas Reheat

## Digit 12 — Blower Configuration

1 = Standard Blower Motor

## Digit 13 — Freeze Protection

A = 20° Freezestat (For Glycol Loop)  
(Extended Range Geothermal)

B = 35° Freezestat (For Water Loop)

## Digit 14 — Open Digit

0 = Open Digit

S = Design Special

## Digit 15 — Supply-Air Arrangement

0 = Standard Supply-Air Arrangement

## Digit 16 — Return-Air Arrangement

0 = Standard Return-Air Arrangement

## Digit 17 — Control Types

D = Deluxe 24V Controls

E = Deluxe 24V Control with  
Programmable Thermostat

H = Symbio™ 400-B/UC400-B

J = Symbio 400-B/UC400-B with Air-Fi®  
Wireless Communications

## Digit 18 — Tstat/Sensor Location

0 = Wall Mounted Location

1 = Unit Mounted Location with Standard  
Entry

2 = Unit Mounted Location with Keylock  
Entry

## Digit 19 — Fault Sensors

1 = Condensate Overflow Sensor

3 = Condensate Overflow and Filter  
Maintenance Timer

6 = Condensate Overflow and Fan Status

J = Condensate Overflow Sensor, Fan  
Status and Filter Maintenance Timer

## Digit 20 — Temperature Sensor

0 = No Additional Temperature Sensor

1 = Entering Water Sensor

## Digit 21 — Open Digit

0 = Open Digit

## Digit 22 — Electric Heat

0 = No Electric Heat

2 = Boilerless Control Electric Heat  
(minimum)

3 = Boilerless Control Electric Heat  
(maximum)

## Digit 23 — Unit Mounted Disconnect

0 = No Unit Mounted Disconnect

A = Power Cord/Receptacle Box

B = Power Cord/Receptacle Box with  
Circuit Breaker

C = On/Off Toggle Switch

## Digit 24 — Filter Type

0 = No Filter; Chassis Only

1 = 1-inch Throwaway Filter

A = 1-inch MERV 8 Filter

## Digit 25 — Acoustic Arrangement

0 = Enhanced Sound Attenuation

## Digit 26 — Factory Configuration

0 = Standard Factory Configuration

(*Chassis, Cabinet and Subbase*)

1 = Chassis ONLY

2 = Low Height Factory Configuration  
(*Chassis, Cabinet and Subbase*)

3 = Extended Length Factory  
Configuration (*Chassis, Cabinet and  
Subbase*)

## Digit 27 — Paint Color

0 = No Paint Selection Available

1 = Deluxe Beige

2 = Cameo White

3 = Soft Dove

## Digit 28 — Outside Air

0 = No Outside Air Option

1 = Outside Air Opening

2 = Motorized Outside Air (*2-position*)

## Digit 29 — Piping Arrangement

L = Left Hand Piping Arrangement

R = Right Hand Piping Arrangement

## Digit 30-36 — Does Not Apply to GEC

0000000 = Digits 30-36 are not applicable  
to the GEC product



# General Data

Table 3. General data

Model Number		006	009	012	015	018
Compressor Type		Rotary	Rotary	Rotary	Rotary	Rotary
Cabinet Size	Length (in.) - standard/extended	48/63	48/63	48/63	48/63	48/63
	Height (in.) - standard/low	25/22.5	25/22.5	25/22.5	25/22.5	25/22.5
	Depth (in.)	12	12	12	12	12
Refrigerant (lbs)	Heating and Cooling	1.47	1.50	1.57	1.69	1.68
	Hot Gas Reheat	1.56	1.59	1.66	1.81	2.06
Approximate weight unit	with Pallet (lb.)	218	219	234	240	242
Approximate weight unit	without Pallet (lb.)	188	189	204	210	212
Approximate weight chassis	with Pallet (lb.)	170	171	186	192	194
Approximate weight chassis	without Pallet (lb.)	140	141	156	162	164
Nominal Filter Size (standard height - 25")		1 x 10 x 32 3/8	1 x 10 x 32 3/8	1 x 10 x 32 3/8	1 x 10 x 32 3/8	1 x 10 x 32 3/8
Nominal Filter Size (low height - 22.5")		1 x 7 3/4 x 30 5/8	1 x 7 3/4 x 30 5/8	1 x 7 3/4 x 30 5/8	1 x 7 3/4 x 30 5/8	1 x 7 3/4 x 30 5/8
Blower Wheel Size		(1) 5 1/4 x 8 1/8	(2) 5 1/4 x 8 1/8	(2) 5 1/4 x 8 1/8	(2) 5 1/4 x 8 1/8	(2) 5 1/4 x 8 1/8



# Performance Data

**Table 4. ANSI/AHRI/ASHRAE/ISO13256-1 WLHP, GWHP and GLHP performance - 0.5 to 1.5 tons<sup>(a)</sup>**

Model	Rated GPM	Rated CFM	Water Loop Heat Pump				Ground Water Heat Pump				Ground Loop Heat Pump			
			Cooling 86°F		Heating 68°F		Cooling 59°F		Heating 50°F		Cooling 77°F		Heating 32°F	
			Capacity Btuh	EER	Capacity Btuh	COP	Capacity Btuh	EER	Capacity Btuh	COP	Capacity Btuh	EER	Capacity Btuh	COP
GECE006	1.8	290	7,500	12.50	9,100	4.70	8,500	18.54	7,600	4.03	7,800	14.42	5,900	3.20
GECE009	2.1	305	8,800	13.10	10,500	4.90	9,900	18.10	9,200	4.13	9,100	14.60	6,800	3.26
GECE012	2.8	430	11,500	13.10	14,100	4.70	12,800	19.11	11,500	3.94	11,900	14.65	9,200	3.26
GECE015	3.5	480	14,700	13.29	17,300	4.61	16,100	19.40	14,300	3.94	15,300	15.23	11,600	3.26
GECE018	4.2	530	16,500	13.00	20,100	4.61	17,700	18.33	16,400	3.94	16,900	14.26	12,900	3.20

(a) Rated in accordance with ANSI/AHRI/ASHRAE/ISO13256-1. Certified conditions are 80.6°F DB/66.2°F WB EAT in cooling and 68°F DB/59°F WB EAT in heating.

**Table 5. Cooling capacities 0.5 tons (net) - GEC006**

EWT	GPM	Total Mbtuh	Sen Mbtuh	SHR	Power kW	EER	Reject Mbtuh	LWT	Feet Head
45	1.1	8.4	6.7	0.79	0.42	20.2	9.8	62.8	1.7
45	1.4	8.4	6.7	0.79	0.40	20.9	9.8	59.0	2.6
45	1.6	8.5	6.7	0.79	0.40	21.2	9.9	57.3	3.3
45	1.7	8.5	6.7	0.79	0.39	21.5	9.8	56.6	3.6
45	1.8	8.5	6.7	0.79	0.39	21.8	9.8	55.9	4.0
45	1.9	8.5	6.7	0.79	0.39	22.0	9.8	55.4	4.3
45	2.0	8.5	6.7	0.79	0.38	22.3	9.8	54.8	4.6
55	1.1	8.1	6.6	0.81	0.45	17.8	9.7	72.6	1.6
55	1.4	8.2	6.6	0.81	0.44	18.4	9.7	68.8	2.6
55	1.6	8.2	6.6	0.81	0.44	18.8	9.7	67.1	3.2
55	1.7	8.2	6.6	0.81	0.43	18.9	9.7	66.4	3.6
55	1.8	8.2	6.6	0.81	0.43	19.1	9.7	65.7	3.9
55	1.9	8.2	6.6	0.80	0.43	19.3	9.7	65.2	4.2
55	2.0	8.2	6.6	0.80	0.42	19.6	9.7	64.7	4.5
68	1.1	7.7	6.4	0.84	0.50	15.3	9.4	85.0	1.6
68	1.4	7.8	6.5	0.83	0.49	15.8	9.5	81.5	2.5
68	1.6	7.8	6.5	0.83	0.49	16.1	9.5	79.8	3.1
68	1.7	7.8	6.5	0.83	0.48	16.2	9.5	79.1	3.5
68	1.8	7.8	6.5	0.83	0.47	16.6	9.4	78.5	3.8
68	1.9	7.9	6.5	0.83	0.48	16.5	9.5	78.0	4.1
68	2.0	7.9	6.5	0.83	0.47	16.7	9.5	77.5	4.4
77	1.1	7.6	6.4	0.84	0.55	13.8	9.4	94.1	1.5
77	1.4	7.6	6.4	0.84	0.53	14.3	9.4	90.4	2.4
77	1.6	7.6	6.4	0.84	0.52	14.5	9.4	88.7	3.0
77	1.7	7.6	6.4	0.84	0.52	14.6	9.4	88.0	3.3
77	1.8	7.6	6.4	0.84	0.52	14.7	9.4	87.4	3.7
77	1.9	7.6	6.4	0.84	0.51	14.8	9.4	86.9	4.0
77	2.0	7.6	6.4	0.84	0.51	14.9	9.4	86.4	4.4
86	1.1	7.5	6.4	0.85	0.61	12.2	9.6	103.4	1.5
86	1.4	7.5	6.4	0.85	0.59	12.7	9.5	99.6	2.3
86	1.6	7.5	6.4	0.85	0.58	12.9	9.5	97.9	2.9





## Performance Data

**Table 5. Cooling capacities 0.5 tons (net) - GEC006 (continued)**

EWT	GPM	Total Mbtuh	Sen Mbtuh	SHR	Power kW	EER	Reject Mbtuh	LWT	Feet Head
86	1.7	7.5	6.4	0.85	0.58	13.0	9.5	97.1	3.2
86	1.8	7.5	6.4	0.85	0.57	13.1	9.5	96.5	3.6
86	1.9	7.5	6.4	0.85	0.57	13.2	9.5	96.0	3.9
86	2.0	7.5	6.4	0.85	0.57	13.3	9.5	95.5	4.3
95	1.1	7.4	6.3	0.86	0.70	10.5	9.7	112.7	1.5
95	1.4	7.4	6.3	0.86	0.67	11.0	9.7	108.8	2.2
95	1.6	7.4	6.3	0.86	0.66	11.2	9.6	107.0	2.8
95	1.7	7.4	6.3	0.86	0.66	11.3	9.6	106.3	3.1
95	1.8	7.4	6.3	0.86	0.65	11.3	9.6	105.7	3.5
95	1.9	7.4	6.3	0.86	0.65	11.4	9.6	105.1	3.8
95	2.0	7.4	6.3	0.86	0.65	11.5	9.6	104.6	4.2
105	1.1	7.1	6.2	0.88	0.94	7.5	10.3	123.7	1.4
105	1.4	7.1	6.2	0.87	0.87	8.2	10.1	119.4	2.2
105	1.6	7.1	6.2	0.87	0.95	7.5	10.3	117.9	2.7
105	1.7	7.1	6.2	0.87	0.93	7.6	10.3	117.1	3.1
105	1.8	7.1	6.2	0.87	0.98	7.3	10.4	116.6	3.4
105	1.9	7.1	6.2	0.87	0.93	7.7	10.3	115.8	3.7
105	2.0	7.1	6.2	0.87	0.93	7.7	10.3	115.3	4.0
115	1.1	6.8	6.1	0.89	1.21	5.6	11.0	134.9	1.2
115	1.4	6.8	6.1	0.89	1.21	5.7	10.9	130.6	2.1
115	1.6	6.8	6.1	0.89	1.20	5.7	10.9	128.7	2.7
115	1.7	6.8	6.1	0.89	1.20	5.7	10.9	127.9	3.0
115	1.8	6.8	6.1	0.89	1.20	5.7	10.9	127.1	3.3
115	1.9	6.8	6.1	0.89	1.20	5.7	10.9	126.5	3.6
115	2.0	6.9	6.1	0.89	1.19	5.7	10.9	125.9	3.9
120	1.1	6.7	6.0	0.90	1.35	5.0	11.3	140.5	1.2
120	1.4	6.7	6.0	0.90	1.34	5.0	11.3	136.1	2.0
120	1.6	6.7	6.0	0.90	1.34	5.0	11.3	134.1	2.6
120	1.7	6.7	6.0	0.90	1.33	5.0	11.3	133.2	2.9
120	1.8	6.7	6.0	0.90	1.33	5.0	11.3	132.5	3.2
120	1.9	6.7	6.0	0.90	1.33	5.0	11.3	131.8	3.5
120	2.0	6.7	6.0	0.90	1.33	5.1	11.3	131.3	3.8

**Note:** Cooling performance data is tabulated at 80.6°F DB/66.2°F WB entering air at ARI/ISO 13256-1 rated cfm. For ARI/ISO 13256-1 certified ratings, see Table 4, p. 21. See Performance correction tables to correct performance at conditions other than those tabulated. Data shown is for unit performance only interpolation is permissible. Extrapolation is not. Rated GPM: 1.8 Minimum cfm 220; Rated cfm 290; Maximum cfm 290.

**Table 6. Heating capacities 0.5 tons (net) - GEC006**

EWT	GPM	Htg. Cap Mbtuh	Absorb Mbtuh	Power kW	COP	LWT	Feet Head
25	1.1	5.3	3.5	0.51	3.0	18.6	2.5
25	1.4	5.4	3.7	0.51	3.1	19.8	3.9
25	1.6	5.5	3.7	0.51	3.2	20.3	4.9
25	1.7	5.5	3.8	0.51	3.2	20.6	5.4
25	1.8	5.5	3.8	0.51	3.2	20.8	6.0
25	1.9	5.6	3.8	0.51	3.2	21.0	6.6
25	2.0	5.6	3.8	0.51	3.2	21.2	7.2

**Table 6. Heating capacities 0.5 tons (net) - GEC006 (continued)**

EWT	GPM	Htg. Cap Mbtuh	Absorb Mbtuh	Power kW	COP	LWT	Feet Head
32	1.1	5.8	4.1	0.51	3.4	24.6	2.5
32	1.4	6.0	4.3	0.51	3.4	25.9	3.8
32	1.6	6.1	4.3	0.51	3.5	26.6	4.7
32	1.7	6.1	4.4	0.51	3.5	26.9	5.3
32	1.8	6.2	4.4	0.51	3.5	27.1	5.8
32	1.9	6.2	4.4	0.51	3.5	27.3	6.4
32	2.0	6.2	4.4	0.51	3.5	27.6	7.0
45	1.1	7.1	5.3	0.52	4.0	35.3	2.0
45	1.4	7.3	5.5	0.52	4.1	37.1	3.0
45	1.6	7.4	5.6	0.52	4.1	38.0	3.8
45	1.7	7.4	5.6	0.52	4.2	38.4	4.2
45	1.8	7.5	5.7	0.52	4.2	38.7	4.7
45	1.9	7.5	5.7	0.52	4.2	39.0	5.1
45	2.0	7.5	5.7	0.52	4.2	39.3	5.6
55	1.1	8.0	6.2	0.53	4.5	43.7	1.9
55	1.4	8.2	6.4	0.53	4.6	45.8	2.9
55	1.6	8.4	6.6	0.53	4.6	46.8	3.7
55	1.7	8.4	6.6	0.53	4.7	47.3	4.1
55	1.8	8.5	6.6	0.53	4.7	47.6	4.5
55	1.9	8.5	6.7	0.53	4.7	48.0	4.9
55	2.0	8.5	6.7	0.53	4.7	48.3	5.4
68	1.1	9.2	7.4	0.54	5.0	54.5	1.8
68	1.4	9.5	7.7	0.54	5.2	57.0	2.8
68	1.6	9.7	7.8	0.54	5.3	58.2	3.5
68	1.7	9.7	7.9	0.54	5.3	58.7	3.9
68	1.8	9.8	7.9	0.54	5.3	59.2	4.3
68	1.9	9.8	8.0	0.54	5.3	59.6	4.7
68	2.0	9.9	8.0	0.54	5.4	60.0	5.2
75	1.1	9.9	8.0	0.54	5.4	60.4	1.8
75	1.4	10.2	8.4	0.54	5.5	63.1	2.7
75	1.6	10.3	8.5	0.54	5.6	64.4	3.4
75	1.7	10.4	8.6	0.54	5.6	64.9	3.8
75	1.8	10.5	8.6	0.54	5.7	65.4	4.2
75	1.9	10.5	8.7	0.54	5.7	65.9	4.6
75	2.0	10.6	8.7	0.54	5.7	66.3	5.0
86	1.1	10.9	9.1	0.54	5.9	69.5	1.7
86	1.4	11.3	9.4	0.55	6.0	72.6	2.6
86	1.6	11.4	9.6	0.55	6.1	74.0	3.3
86	1.7	11.5	9.6	0.55	6.2	74.7	3.7
86	1.8	11.6	9.7	0.55	6.2	75.2	4.1
86	1.9	11.6	9.7	0.55	6.2	75.7	4.4
86	2.0	11.7	9.8	0.55	6.3	76.2	4.9

**Note:** Heating performance data is tabulated at 68°F DB entering air at ARI/ISO 13256-1 rated cfm. For ARI/ISO 13256-1 certified ratings, see [Table 4, p. 21](#). See Performance correction tables to correct performance at conditions other than those tabulated. Data shown is for unit performance only. Interpolation is permissible. Extrapolation is not. Rated GPM: 1.8 Minimum cfm 220; Rated cfm 290; Maximum cfm 290.



## Performance Data

**Table 7. Fan correction factors 0.5 tons - GEC006**

Entering cfm	Cooling Capacity	Sensible Capacity	Cooling Input Watts	Heating Capacity	Heating Input Watts
220	0.962	0.860	1.012	0.984	1.087
290	1.000	1.000	1.000	1.000	1.000

**Table 8. Cooling capacities 0.75 tons (net) - GEC009**

EWT	GPM	Total Mbtuh	Sen Mbtuh	SHR	Power kW	EER	Reject Mbtuh	LWT	Feet Head
45	1.4	10.6	8.6	0.82	0.46	22.9	12.2	62.4	2.1
45	1.7	10.7	8.5	0.80	0.46	23.2	12.2	59.4	3.3
45	1.9	10.7	8.4	0.78	0.46	23.3	12.3	57.9	4.1
45	2.1	10.7	8.2	0.77	0.46	23.5	12.3	56.7	5.0
45	2.2	10.8	8.3	0.77	0.46	23.7	12.3	56.2	5.4
45	2.3	10.8	8.3	0.76	0.45	23.8	12.4	55.7	5.8
45	2.5	10.9	8.3	0.76	0.45	24.0	12.4	54.9	6.7
55	1.4	9.2	7.4	0.80	0.51	18.2	11.0	70.7	2.3
55	1.7	9.8	7.8	0.80	0.50	19.7	11.5	68.6	3.4
55	1.9	9.9	7.9	0.79	0.49	20.1	11.6	67.2	4.1
55	2.1	10.0	7.9	0.79	0.49	20.5	11.7	66.1	4.9
55	2.2	10.1	7.9	0.79	0.49	20.6	11.7	65.7	5.2
55	2.3	10.1	8.0	0.79	0.49	20.8	11.8	65.2	5.6
55	2.5	10.2	8.0	0.78	0.48	21.2	11.9	64.5	6.4
68	1.4	9.0	7.5	0.83	0.55	16.2	10.8	83.5	2.2
68	1.7	9.1	7.5	0.82	0.54	16.8	10.9	80.9	3.1
68	1.9	9.2	7.5	0.81	0.54	17.1	11.0	79.6	3.8
68	2.1	9.2	7.5	0.82	0.53	17.3	11.0	78.5	4.6
68	2.2	9.3	7.5	0.80	0.53	17.6	11.1	78.1	4.9
68	2.3	9.3	7.5	0.81	0.53	17.5	11.1	77.6	5.4
68	2.5	9.1	7.5	0.83	0.53	17.1	10.9	76.7	6.2
77	1.4	8.7	7.4	0.85	0.60	14.5	10.8	92.4	2.2
77	1.7	8.8	7.4	0.85	0.59	14.9	10.8	89.7	3.0
77	1.9	8.8	7.4	0.84	0.58	15.1	10.8	88.4	3.7
77	2.1	8.8	7.4	0.84	0.58	15.3	10.8	87.3	4.4
77	2.2	8.8	7.4	0.84	0.57	15.4	10.8	86.8	4.8
77	2.3	8.8	7.4	0.85	0.57	15.4	10.7	86.3	5.2
77	2.5	8.9	7.5	0.83	0.57	15.7	10.9	85.7	6.0
86	1.4	8.6	7.4	0.86	0.67	12.7	10.9	101.5	2.1
86	1.7	8.6	7.4	0.86	0.65	13.1	10.8	98.7	3.0
86	1.9	8.6	7.4	0.85	0.65	13.3	10.8	97.4	3.6
86	2.1	8.6	7.4	0.85	0.64	13.5	10.8	96.3	4.3
86	2.2	8.6	7.4	0.85	0.64	13.6	10.8	95.8	4.7
86	2.3	8.6	7.4	0.85	0.64	13.6	10.8	95.4	5.1
86	2.5	8.7	7.4	0.85	0.63	13.7	10.8	94.7	5.9
95	1.4	8.4	7.3	0.87	0.78	10.9	11.1	110.9	2.0
95	1.7	8.5	7.3	0.86	0.76	11.1	11.1	108.0	2.9
95	1.9	8.5	7.3	0.86	0.75	11.3	11.0	106.6	3.5

**Table 8. Cooling capacities 0.75 tons (net) - GEC009 (continued)**

EWT	GPM	Total Mbtuh	Sen Mbtuh	SHR	Power kW	EER	Reject Mbtuh	LWT	Feet Head
95	2.1	8.4	7.3	0.86	0.73	11.5	10.9	105.4	4.2
95	2.2	8.5	7.3	0.86	0.74	11.4	11.0	105.0	4.5
95	2.3	8.4	7.3	0.87	0.72	11.7	10.9	104.5	4.9
95	2.5	8.4	7.3	0.87	0.72	11.8	10.9	103.7	5.7
105	1.4	8.5	7.3	0.86	1.06	8.0	12.1	122.3	2.0
105	1.7	8.4	7.3	0.87	0.94	8.9	11.6	118.6	2.9
105	1.9	8.4	7.3	0.87	0.93	9.0	11.5	117.1	3.5
105	2.1	8.4	7.3	0.87	0.91	9.2	11.5	115.9	4.2
105	2.2	8.4	7.3	0.87	0.90	9.2	11.4	115.4	4.5
105	2.3	8.4	7.3	0.87	0.90	9.3	11.4	114.9	4.9
105	2.5	8.4	7.3	0.87	0.88	9.5	11.4	114.1	5.5
115	1.4	8.2	7.2	0.88	1.12	7.3	12.1	132.2	1.8
115	1.7	8.2	7.2	0.88	1.10	7.5	12.0	129.1	2.8
115	1.9	8.2	7.2	0.88	1.08	7.6	11.9	127.6	3.5
115	2.1	8.2	7.2	0.88	1.07	7.7	11.9	126.3	4.1
115	2.2	8.2	7.2	0.88	1.06	7.8	11.8	125.8	4.5
115	2.3	8.2	7.2	0.88	1.05	7.8	11.8	125.3	4.8
115	2.5	8.2	7.2	0.88	1.03	8.0	11.8	124.4	5.5
120	1.4	8.2	7.2	0.88	1.20	6.8	12.3	137.5	1.8
120	1.7	8.2	7.2	0.88	1.17	7.0	12.2	134.3	2.8
120	1.9	8.2	7.2	0.88	1.16	7.1	12.1	132.8	3.4
120	2.1	8.2	7.2	0.88	1.14	7.2	12.1	131.5	4.1
120	2.2	8.2	7.2	0.88	1.13	7.2	12.0	130.9	4.4
120	2.3	8.2	7.2	0.88	1.13	7.3	12.0	130.4	4.8
120	2.5	8.2	7.2	0.88	1.11	7.4	12.0	129.6	5.4

**Note:** Cooling performance data is tabulated at 80.6°F DB/66.2°F WB entering air at ARI/ISO 13256-1 rated cfm. For ARI/ISO 13256-1 certified ratings, see Table 4, p. 21. See Performance correction tables to correct performance at conditions other than those tabulated. Data shown is for unit performance only interpolation is permissible. Extrapolation is not. Rated GPM: 2.1 Minimum cfm 240; Rated cfm 305; Maximum cfm 305.

**Table 9. Heating capacities 0.75 tons (net) - GEC009**

EWT	GPM	Htg. Cap Mbtuh	Absorb Mbtuh	Power kW	COP	LWT	Feet Head
25	1.4	6.1	4.2	0.56	3.2	19.0	3.5
25	1.7	6.3	4.4	0.56	3.3	19.9	4.9
25	1.9	6.3	4.4	0.56	3.3	20.3	5.9
25	2.1	6.4	4.5	0.56	3.3	20.7	7.1
25	2.2	6.4	4.5	0.56	3.4	20.9	7.6
25	2.3	6.4	4.5	0.56	3.4	21.1	8.3
25	2.5	6.5	4.6	0.56	3.4	21.4	9.6
32	1.4	6.8	4.9	0.57	3.5	25.0	3.4
32	1.7	7.0	5.0	0.57	3.6	26.1	4.7
32	1.9	7.0	5.1	0.57	3.6	26.6	5.7
32	2.1	7.1	5.1	0.57	3.7	27.1	6.8
32	2.2	7.1	5.2	0.57	3.7	27.3	7.4
32	2.3	7.1	5.2	0.57	3.7	27.5	8.0
32	2.5	7.2	5.2	0.57	3.7	27.8	9.3





## Performance Data

**Table 9. Heating capacities 0.75 tons (net) - GEC009 (continued)**

EWT	GPM	Htg. Cap Mbtuh	Absorb Mbtuh	Power kW	COP	LWT	Feet Head
45	1.4	8.3	6.3	0.58	4.2	36.0	2.7
45	1.7	8.4	6.4	0.58	4.2	37.4	3.8
45	1.9	8.5	6.5	0.58	4.3	38.1	4.6
45	2.1	8.6	6.6	0.58	4.3	38.7	5.5
45	2.2	8.6	6.6	0.59	4.3	39.0	6.0
45	2.3	8.7	6.7	0.58	4.3	39.2	6.4
45	2.5	8.7	6.7	0.59	4.4	39.6	7.5
55	1.4	9.3	7.3	0.59	4.6	44.6	2.6
55	1.7	9.5	7.5	0.59	4.7	46.2	3.7
55	1.9	9.6	7.6	0.59	4.8	47.0	4.4
55	2.1	9.7	7.7	0.59	4.8	47.7	5.3
55	2.2	9.8	7.7	0.59	4.8	48.0	5.7
55	2.3	9.8	7.8	0.59	4.8	48.2	6.2
55	2.5	9.9	7.8	0.59	4.9	48.7	7.2
68	1.4	10.7	8.7	0.60	5.3	55.6	2.5
68	1.7	11.0	8.9	0.60	5.4	57.5	3.5
68	1.9	11.1	9.0	0.60	5.4	58.5	4.2
68	2.1	11.2	9.1	0.60	5.5	59.3	5.0
68	2.2	11.2	9.2	0.60	5.5	59.6	5.5
68	2.3	11.3	9.2	0.60	5.5	60.0	5.9
68	2.5	11.4	9.3	0.60	5.5	60.6	6.8
75	1.4	11.5	9.4	0.60	5.6	61.5	2.4
75	1.7	11.7	9.7	0.60	5.7	63.6	3.4
75	1.9	11.9	9.8	0.60	5.8	64.7	4.1
75	2.1	12.0	9.9	0.61	5.8	65.6	4.9
75	2.2	12.0	10.0	0.61	5.8	65.9	5.3
75	2.3	12.1	10.0	0.61	5.8	66.3	5.8
75	2.5	12.2	10.1	0.61	5.9	66.9	6.7
86	1.4	12.6	10.6	0.61	6.1	70.9	2.4
86	1.7	12.9	10.8	0.61	6.2	73.2	3.3
86	1.9	13.1	11.0	0.61	6.3	74.4	4.0
86	2.1	13.2	11.1	0.61	6.3	75.4	4.8
86	2.2	13.2	11.2	0.61	6.3	75.9	5.2
86	2.3	13.3	11.2	0.61	6.4	76.3	5.6
86	2.5	13.4	11.3	0.61	6.4	77.0	6.4

**Note:** Heating performance data is tabulated at 68°F DB entering air at ARI/ISO 13256-1 rated cfm. For ARI/ISO 13256-1 certified ratings, see [Table 4, p. 21](#). See Performance correction tables to correct performance at conditions other than those tabulated. Data shown is for unit performance only. Interpolation is permissible. Extrapolation is not. Rated GPM: 2.1 Minimum cfm 240; Rated cfm 305; Maximum cfm 305.

**Table 10. Fan correction factory 0.75 tons - GEC009**

Entering cfm	Cooling Capacity	Sensible Capacity	Cooling Input Watts	Heating Capacity	Heating Input Watts
240	0.959	0.850	0.978	0.984	1.080
305	1.000	1.000	1.000	1.000	1.000

**Table 11. Cooling capacities 1 tons (net) - GEC012**

EWT	GPM	Total Mbtuh	Sen Mbtuh	SHR	Power kW	EER	Reject Mbtuh	LWT	Feet Head
45	1.8	12.6	9.9	0.78	0.54	23.5	14.4	61.0	4.9
45	2.2	12.7	9.9	0.78	0.52	24.2	14.5	58.1	7.3
45	2.5	12.7	9.9	0.78	0.52	24.7	14.5	56.6	9.1
45	2.8	12.8	9.9	0.78	0.51	25.2	14.5	55.4	10.7
45	2.9	12.8	9.9	0.78	0.50	25.3	14.5	55.0	11.4
45	3.1	12.8	9.9	0.77	0.50	25.5	14.5	54.4	12.9
45	3.4	12.8	9.9	0.77	0.50	25.8	14.5	53.5	15.1
55	1.8	12.2	9.8	0.80	0.60	20.5	14.3	70.8	4.5
55	2.2	12.3	9.8	0.80	0.59	20.9	14.3	68.0	6.9
55	2.5	12.3	9.8	0.79	0.57	21.5	14.3	66.4	8.5
55	2.8	12.4	9.8	0.79	0.57	21.9	14.3	65.2	10.3
55	2.9	12.4	9.8	0.79	0.56	21.9	14.3	64.9	11.0
55	3.1	12.4	9.8	0.79	0.56	22.1	14.3	64.2	12.4
55	3.4	12.5	9.8	0.79	0.56	22.4	14.4	63.4	14.2
68	1.8	11.7	9.6	0.82	0.68	17.1	14.0	83.6	4.5
68	2.2	11.8	9.7	0.82	0.67	17.6	14.1	80.8	6.4
68	2.5	11.8	9.7	0.82	0.66	17.9	14.1	79.3	8.1
68	2.8	11.9	9.7	0.81	0.65	18.2	14.1	78.1	9.9
68	2.9	11.9	9.7	0.81	0.65	18.3	14.1	77.7	10.7
68	3.1	11.9	9.7	0.81	0.65	18.4	14.1	77.1	11.8
68	3.4	11.9	9.7	0.81	0.64	18.6	14.1	76.3	13.9
77	1.8	11.6	9.6	0.83	0.76	15.2	14.2	92.8	4.4
77	2.2	11.6	9.6	0.83	0.74	15.7	14.2	89.9	6.2
77	2.5	11.6	9.6	0.83	0.73	15.9	14.1	88.3	7.8
77	2.8	11.6	9.6	0.83	0.72	16.1	14.1	87.1	9.6
77	2.9	11.7	9.6	0.83	0.72	16.2	14.1	86.7	10.2
77	3.1	11.7	9.6	0.83	0.72	16.3	14.1	86.1	11.5
77	3.4	11.7	9.6	0.83	0.71	16.4	14.1	85.3	13.5
86	1.8	11.5	9.6	0.84	0.86	13.3	14.4	102.0	4.3
86	2.2	11.5	9.6	0.83	0.84	13.7	14.3	99.0	6.1
86	2.5	11.5	9.6	0.83	0.82	14.0	14.3	97.5	7.6
86	2.8	11.5	9.6	0.83	0.81	14.1	14.3	96.2	9.3
86	2.9	11.5	9.6	0.83	0.81	14.2	14.3	95.9	9.9
86	3.1	11.5	9.6	0.83	0.81	14.3	14.3	95.2	11.1
86	3.4	11.5	9.6	0.83	0.80	14.4	14.2	94.4	13.1
95	1.8	11.3	9.6	0.85	0.99	11.4	14.7	111.3	4.1
95	2.2	11.3	9.6	0.84	0.96	11.8	14.6	108.3	5.9
95	2.5	11.3	9.6	0.84	0.95	12.0	14.5	106.6	7.4
95	2.8	11.3	9.6	0.84	0.93	12.1	14.5	105.4	9.1
95	2.9	11.3	9.6	0.84	0.93	12.1	14.5	105.0	9.6
95	3.1	11.3	9.6	0.84	0.93	12.2	14.5	104.3	10.8
95	3.4	11.3	9.6	0.84	0.92	12.3	14.5	103.5	12.7
105	1.8	11.0	9.5	0.86	1.23	8.9	15.2	121.9	4.0
105	2.2	11.0	9.5	0.86	1.20	9.2	15.1	118.7	5.7



## Performance Data

**Table 11. Cooling capacities 1 tons (net) - GEC012 (continued)**

EWT	GPM	Total Mbtuh	Sen Mbtuh	SHR	Power kW	EER	Reject Mbtuh	LWT	Feet Head
105	2.5	11.0	9.5	0.86	1.18	9.3	15.0	117.0	7.2
105	2.8	11.0	9.5	0.87	1.16	9.4	14.9	115.7	8.8
105	2.9	11.0	9.5	0.87	1.16	9.5	14.9	115.3	9.4
105	3.1	11.0	9.5	0.86	1.15	9.5	14.9	114.6	10.5
105	3.4	11.0	9.5	0.86	1.14	9.6	14.9	113.7	12.4
115	1.8	10.6	9.4	0.89	1.45	7.3	15.6	132.3	3.5
115	2.2	10.6	9.4	0.89	1.43	7.4	15.5	129.1	5.6
115	2.5	10.6	9.4	0.89	1.41	7.5	15.5	127.4	7.2
115	2.8	10.6	9.4	0.89	1.40	7.6	15.4	126.0	8.7
115	2.9	10.6	9.4	0.89	1.39	7.6	15.4	125.6	9.3
115	3.1	10.6	9.4	0.89	1.38	7.7	15.4	124.9	10.3
115	3.4	10.6	9.4	0.89	1.37	7.8	15.3	124.0	11.9
120	1.8	10.5	9.4	0.90	1.57	6.7	15.8	137.6	3.3
120	2.2	10.5	9.4	0.90	1.55	6.8	15.7	134.3	5.4
120	2.5	10.5	9.4	0.90	1.53	6.8	15.7	132.6	7.0
120	2.8	10.5	9.4	0.90	1.52	6.9	15.6	131.2	8.6
120	2.9	10.5	9.4	0.90	1.51	6.9	15.6	130.8	9.1
120	3.1	10.5	9.4	0.90	1.50	7.0	15.6	130.1	10.2
120	3.4	10.5	9.4	0.90	1.49	7.0	15.5	129.1	11.8

**Note:** Cooling performance data is tabulated at 80.6°F DB/66.2°F WB entering air at ARI/ISO 13256-1 rated cfm. For ARI/ISO 13256-1 certified ratings, see Table 4, p. 21. See Performance correction tables to correct performance at conditions other than those tabulated. Data shown is for unit performance only interpolation is permissible. Extrapolation is not. Rated GPM: 2.8 Minimum cfm 360; Rated cfm 430; Maximum cfm 430.

**Table 12. Heating capacities 1 tons (net) - GEC012**

EWT	GPM	Htg. Cap Mbtuh	Absorb Mbtuh	Power kW	COP	LWT	Feet Head
25	1.8	8.4	5.8	0.77	3.2	18.6	6.9
25	2.2	8.5	5.9	0.77	3.2	19.6	9.8
25	2.5	8.6	6.0	0.77	3.3	20.2	12.3
25	2.8	8.6	6.0	0.77	3.3	20.7	14.9
25	2.9	8.7	6.0	0.77	3.3	20.8	15.9
25	3.1	8.7	6.1	0.77	3.3	21.1	17.8
25	3.4	8.7	6.1	0.77	3.3	21.4	20.9
32	1.8	9.2	6.5	0.77	3.5	24.8	6.7
32	2.2	9.3	6.7	0.78	3.5	25.9	9.5
32	2.5	9.4	6.8	0.78	3.5	26.6	11.9
32	2.8	9.5	6.8	0.78	3.6	27.1	14.5
32	2.9	9.5	6.8	0.78	3.6	27.3	15.4
32	3.1	9.5	6.9	0.78	3.6	27.6	17.3
32	3.4	9.6	6.9	0.78	3.6	27.9	20.3
45	1.8	10.9	8.2	0.79	4.0	35.9	5.4
45	2.2	11.1	8.3	0.79	4.1	37.4	7.7
45	2.5	11.1	8.4	0.79	4.1	38.3	9.6
45	2.8	11.2	8.5	0.80	4.1	38.9	11.7
45	2.9	11.3	8.5	0.80	4.1	39.1	12.4
45	3.1	11.3	8.6	0.80	4.2	39.5	13.9

**Table 12. Heating capacities 1 tons (net) - GEC012 (continued)**

EWT	GPM	Htg. Cap Mbtuh	Absorb Mbtuh	Power kW	COP	LWT	Feet Head
45	3.4	11.4	8.6	0.80	4.2	39.9	16.3
55	1.8	12.2	9.4	0.81	4.4	44.6	5.2
55	2.2	12.4	9.6	0.81	4.5	46.3	7.4
55	2.5	12.5	9.7	0.81	4.5	47.2	9.2
55	2.8	12.6	9.8	0.81	4.6	48.0	11.2
55	2.9	12.6	9.9	0.81	4.6	48.2	11.9
55	3.1	12.7	9.9	0.81	4.6	48.6	13.4
55	3.4	12.7	10.0	0.81	4.6	49.1	15.7
68	1.8	13.9	11.1	0.82	4.9	55.7	5.0
68	2.2	14.1	11.3	0.82	5.0	57.7	7.0
68	2.5	14.3	11.5	0.83	5.1	58.8	8.8
68	2.8	14.4	11.6	0.83	5.1	59.7	10.7
68	2.9	14.4	11.6	0.83	5.1	60.0	11.4
68	3.1	14.5	11.7	0.83	5.1	60.5	12.8
68	3.4	14.6	11.7	0.83	5.2	61.1	15.0
75	1.8	14.8	11.9	0.83	5.2	61.7	4.9
75	2.2	15.1	12.2	0.83	5.3	63.9	6.9
75	2.5	15.2	12.4	0.84	5.3	65.1	8.6
75	2.8	15.4	12.5	0.84	5.4	66.1	10.4
75	2.9	15.4	12.5	0.84	5.4	66.4	11.1
75	3.1	15.5	12.6	0.84	5.4	66.9	12.5
75	3.4	15.6	12.7	0.84	5.4	67.5	14.6
86	1.8	16.2	13.3	0.85	5.6	71.2	4.7
86	2.2	16.6	13.6	0.86	5.7	73.6	6.6
86	2.5	16.7	13.8	0.86	5.7	75.0	8.3
86	2.8	16.9	13.9	0.86	5.7	76.0	10.1
86	2.9	16.9	14.0	0.86	5.8	76.4	10.7
86	3.1	17.0	14.1	0.86	5.8	76.9	12.0
86	3.4	17.1	14.1	0.87	5.8	77.7	14.1
86	1.8	8.4	5.8	0.77	3.2	18.6	6.9

**Note:** Heating performance data is tabulated at 68°F DB entering air at AHRI/ISO 13256-1 rated CFM. For AHRI/ISO 13256-1 certified ratings, see [Table 4, p. 21](#). See Performance correction tables to correct performance at conditions other than those tabulated. Data shown is for unit performance only. Interpolation is permissible. Extrapolation is not. Rated GPM: 2.8 Minimum cfm 360; Rated cfm 430; Maximum cfm 430.

**Table 13. Fan correction factory 1 tons - GEC012**

Entering cfm	Cooling Capacity	Sensible Capacity	Cooling Input Watts	Heating Capacity	Heating Input Watts
360	0.969	0.882	1.006	0.994	1.063
430	1.000	1.000	1.000	1.000	1.000

**Table 14. Cooling capacities 1.25 tons (net) - GEC015**

EWT	GPM	Total Mbtuh	Sen Mbtuh	SHR	Power kW	EER	Reject Mbtuh	LWT	Feet Head
45	2.2	16.0	12.6	0.78	0.61	26.3	18.1	61.4	6.6
45	2.8	16.1	12.6	0.78	0.57	28.1	18.1	57.9	10.2
45	3.1	16.2	12.6	0.78	0.56	28.8	18.1	56.7	12.2





## Performance Data

**Table 14. Cooling capacities 1.25 tons (net) - GEC015 (continued)**

EWT	GPM	Total Mbtuh	Sen Mbtuh	SHR	Power kW	EER	Reject Mbtuh	LWT	Feet Head
45	3.5	16.3	12.7	0.78	0.55	29.6	18.1	55.4	15.1
45	3.6	16.3	12.7	0.78	0.55	29.8	18.1	55.1	15.9
45	3.8	16.3	12.7	0.78	0.54	30.1	18.1	54.5	17.5
45	4.2	16.3	12.7	0.78	0.53	30.7	18.1	53.6	20.9
55	2.2	15.5	12.4	0.80	0.72	21.7	18.0	71.3	6.4
55	2.8	15.7	12.5	0.79	0.68	22.9	18.0	67.9	9.8
55	3.1	15.7	12.4	0.79	0.67	23.4	18.0	66.6	11.7
55	3.5	15.8	12.5	0.79	0.66	23.9	18.0	65.3	14.5
55	3.6	15.8	12.5	0.79	0.66	24.0	18.1	65.0	15.3
55	3.8	15.8	12.5	0.79	0.65	24.3	18.0	64.5	16.8
55	4.2	15.9	12.5	0.79	0.64	24.6	18.1	63.6	20.1
68	2.2	14.9	12.1	0.81	0.85	17.4	17.8	84.2	6.1
68	2.8	15.0	12.1	0.81	0.82	18.2	17.8	80.7	9.3
68	3.1	15.0	12.0	0.80	0.81	18.5	17.8	79.5	11.2
68	3.5	15.1	12.2	0.81	0.80	18.9	17.8	78.2	13.9
68	3.6	15.1	12.2	0.80	0.80	19.0	17.9	77.9	14.6
68	3.8	15.2	12.2	0.81	0.79	19.1	17.9	77.4	16.0
68	4.2	15.2	12.1	0.80	0.79	19.4	17.9	76.5	19.1
77	2.2	14.7	12.0	0.81	0.97	15.2	18.0	93.4	5.9
77	2.8	14.7	12.0	0.81	0.93	15.8	17.9	89.8	9.1
77	3.1	14.7	12.0	0.81	0.92	16.0	17.9	88.5	10.9
77	3.5	14.8	12.0	0.81	0.90	16.3	17.9	87.2	13.5
77	3.6	14.8	12.1	0.82	0.90	16.4	17.9	86.9	14.1
77	3.8	14.8	12.0	0.81	0.89	16.5	17.8	86.4	15.6
77	4.2	14.8	12.0	0.81	0.88	16.7	17.8	85.5	18.6
86	2.2	14.5	11.9	0.82	1.09	13.3	18.3	102.6	5.7
86	2.8	14.6	11.9	0.82	1.05	13.8	18.2	99.0	8.8
86	3.1	14.6	11.9	0.82	1.04	14.0	18.1	97.7	10.6
86	3.5	14.6	11.9	0.82	1.03	14.2	18.1	96.3	13.1
86	3.6	14.6	11.9	0.82	1.02	14.3	18.1	96.0	13.7
86	3.8	14.6	11.9	0.82	1.02	14.4	18.1	95.5	15.1
86	4.2	14.6	11.9	0.81	1.01	14.5	18.0	94.6	18.0
95	2.2	14.3	11.8	0.82	1.24	11.5	18.6	111.9	5.6
95	2.8	14.3	11.8	0.82	1.20	12.0	18.4	108.2	8.6
95	3.1	14.3	11.8	0.82	1.19	12.1	18.4	106.9	10.3
95	3.5	14.3	11.7	0.82	1.17	12.2	18.3	105.5	12.7
95	3.6	14.3	11.8	0.82	1.17	12.3	18.3	105.2	13.4
95	3.8	14.3	11.8	0.82	1.16	12.3	18.3	104.6	14.7
95	4.2	14.4	11.8	0.82	1.15	12.5	18.3	103.7	17.6
105	2.2	14.1	11.6	0.83	1.52	9.2	19.3	122.5	5.4
105	2.8	14.0	11.6	0.83	1.47	9.5	19.1	118.6	8.3
105	3.1	14.0	11.6	0.83	1.45	9.7	19.0	117.2	10.0
105	3.5	14.0	11.6	0.83	1.43	9.8	18.9	115.8	12.4
105	3.6	14.0	11.6	0.83	1.44	9.7	18.9	115.5	13.0
105	3.8	14.0	11.6	0.83	1.42	9.9	18.9	114.9	14.3

**Table 14. Cooling capacities 1.25 tons (net) - GEC015 (continued)**

EWT	GPM	Total Mbtuh	Sen Mbtuh	SHR	Power kW	EER	Reject Mbtuh	LWT	Feet Head
105	4.2	14.0	11.6	0.83	1.41	10.0	18.8	114.0	17.1
115	2.2	13.7	11.5	0.84	1.76	7.8	19.7	133.0	4.5
115	2.8	13.7	11.5	0.84	1.73	7.9	19.6	129.0	8.1
115	3.1	13.7	11.5	0.84	1.72	8.0	19.6	127.6	9.9
115	3.5	13.7	11.5	0.84	1.70	8.1	19.5	126.2	12.3
115	3.6	13.7	11.5	0.84	1.70	8.1	19.5	125.8	12.9
115	3.8	13.7	11.5	0.84	1.69	8.1	19.5	125.2	14.1
115	4.2	13.7	11.5	0.84	1.67	8.2	19.4	124.2	16.5
120	2.2	13.6	11.4	0.84	1.90	7.2	20.0	138.2	4.4
120	2.8	13.6	11.4	0.84	1.87	7.3	19.9	134.2	8.0
120	3.1	13.6	11.4	0.84	1.85	7.3	19.9	132.8	9.8
120	3.5	13.5	11.4	0.84	1.83	7.4	19.8	131.3	12.2
120	3.6	13.5	11.4	0.84	1.83	7.4	19.8	131.0	12.8
120	3.8	13.5	11.4	0.84	1.82	7.4	19.8	130.4	14.0
120	4.2	13.5	11.4	0.84	1.80	7.5	19.7	129.4	16.4

**Note:** Cooling performance data is tabulated at 80.6°F DB/66.2°F WB entering air at ARI/ISO 13256-1 rated cfm. For ARI/ISO 13256-1 certified ratings, see [Table 4, p. 21](#). See Performance correction tables to correct performance at conditions other than those tabulated. Data shown is for unit performance only interpolation is permissible. Extrapolation is not. Rated GPM: 3.5 Minimum cfm 400; Rated cfm 480; Maximum cfm 480.

**Table 15. Heating capacities 1.25 tons (net) - GEC015**

EWT	GPM	Htg. Cap Mbtuh	Absorb Mbtuh	Power kW	COP	LWT	Feet Head
25	2.2	10.5	7.3	0.93	3.3	18.3	9.3
25	2.8	10.7	7.5	0.94	3.4	19.6	14.2
25	3.1	10.8	7.6	0.93	3.4	20.1	16.9
25	3.5	10.9	7.7	0.94	3.4	20.6	20.9
25	3.6	10.9	7.7	0.94	3.4	20.7	21.9
25	3.8	10.9	7.7	0.94	3.4	20.9	24.1
25	4.2	11.0	7.8	0.94	3.4	21.3	28.7
32	2.2	11.4	8.2	0.95	3.5	24.5	9.0
32	2.8	11.7	8.4	0.95	3.6	26.0	13.7
32	3.1	11.8	8.5	0.95	3.6	26.5	16.4
32	3.5	11.9	8.6	0.95	3.6	27.1	20.3
32	3.6	11.9	8.6	0.95	3.6	27.2	21.3
32	3.8	11.9	8.7	0.95	3.7	27.4	23.4
32	4.2	12.0	8.7	0.95	3.7	27.8	27.8
45	2.2	13.5	10.1	0.98	4.0	35.8	7.3
45	2.8	13.8	10.4	0.98	4.1	37.6	11.1
45	3.1	13.8	10.5	0.98	4.1	38.2	13.2
45	3.5	13.9	10.6	0.98	4.2	38.9	16.3
45	3.6	14.0	10.6	0.98	4.2	39.1	17.1
45	3.8	14.0	10.7	0.98	4.2	39.4	18.8
45	4.2	14.1	10.7	0.98	4.2	39.9	22.4
55	2.2	15.0	11.6	0.99	4.4	44.5	7.0
55	2.8	15.3	11.9	1.00	4.5	46.5	10.6
55	3.1	15.5	12.0	1.00	4.5	47.2	12.7



## Performance Data

**Table 15. Heating capacities 1.25 tons (net) - GEC015 (continued)**

EWT	GPM	Htg. Cap Mbtuh	Absorb Mbtuh	Power kW	COP	LWT	Feet Head
55	3.5	15.5	12.1	1.00	4.6	48.1	15.7
55	3.6	15.6	12.2	1.00	4.6	48.2	16.5
55	3.8	15.6	12.2	1.00	4.6	48.6	18.1
55	4.2	15.7	12.3	1.00	4.6	49.1	21.5
68	2.2	17.0	13.6	1.00	5.0	55.7	6.7
68	2.8	17.4	13.9	1.00	5.1	58.0	10.1
68	3.1	17.5	14.1	1.00	5.1	58.9	12.1
68	3.5	17.7	14.3	1.01	5.2	59.8	14.9
68	3.6	17.7	14.3	1.00	5.2	60.1	15.7
68	3.8	17.7	14.3	1.00	5.2	60.5	17.2
68	4.2	17.9	14.4	1.00	5.2	61.1	20.5
75	2.2	18.1	14.6	1.00	5.3	61.7	6.5
75	2.8	18.5	15.1	1.01	5.4	64.2	9.9
75	3.1	18.6	15.2	1.00	5.4	65.2	11.8
75	3.5	18.8	15.4	1.00	5.5	66.2	14.6
75	3.6	18.8	15.4	1.00	5.5	66.4	15.3
75	3.8	18.9	15.5	1.00	5.5	66.9	16.8
75	4.2	19.0	15.6	1.00	5.6	67.6	20.0
86	2.2	19.7	16.3	1.00	5.8	71.2	6.3
86	2.8	20.2	16.8	0.99	6.0	74.0	9.6
86	3.1	20.3	17.0	0.99	6.0	75.1	11.4
86	3.5	20.5	17.2	0.99	6.1	76.2	14.1
86	3.6	20.5	17.1	0.99	6.1	76.5	14.8
86	3.8	20.6	17.2	0.98	6.1	76.9	16.2
86	4.2	20.8	17.4	0.98	6.2	77.7	19.3

**Note:** Heating performance data is tabulated at 68°F DB entering air at AHRI/ISO 13256-1 rated CFM. For AHRI/ISO 13256-1 certified ratings, see [Table 4, p. 21](#). See Performance correction tables to correct performance at conditions other than those tabulated. Data shown is for unit performance only. Interpolation is permissible. Extrapolation is not. Rated GPM: 3.5 Minimum cfm 400; Rated cfm 480; Maximum cfm 480.

**Table 16. Fan correction factory 1.25 tons - GEC015**

Entering cfm	Cooling Capacity	Sensible Capacity	Cooling Input Watts	Heating Capacity	Heating Input Watts
400	0.966	0.911	1.007	0.987	400
480	1.000	1.000	1.000	1.000	480

**Table 17. Cooling capacities 1.5 tons (net) - GEC018**

EWT	GPM	Total Mbtuh	Sen Mbtuh	SHR	Power kW	EER	Reject Mbtuh	LWT	Feet Head
45	2.7	18.4	13.9	0.76	0.78	23.6	21.0	60.6	4.8
45	3.3	18.4	13.9	0.75	0.76	24.4	21.0	57.7	6.9
45	3.7	18.5	13.9	0.75	0.75	24.7	21.0	56.4	8.4
45	4.2	18.5	13.9	0.75	0.74	25.1	21.0	55.0	10.6
45	4.4	18.5	14.0	0.75	0.73	25.3	21.0	54.5	11.5
45	4.6	18.5	14.0	0.75	0.73	25.4	21.0	54.1	12.4
45	5.0	18.5	14.0	0.75	0.72	25.6	21.0	53.4	14.4
55	2.7	18.0	13.7	0.76	0.87	20.6	21.0	70.5	4.6

**Table 17. Cooling capacities 1.5 tons (net) - GEC018 (continued)**

EWT	GPM	Total Mbtuh	Sen Mbtuh	SHR	Power kW	EER	Reject Mbtuh	LWT	Feet Head
55	3.3	18.0	13.8	0.76	0.85	21.2	20.9	67.7	6.6
55	3.7	18.1	13.8	0.76	0.84	21.6	20.9	66.3	8.1
55	4.2	18.1	13.8	0.76	0.83	21.9	20.9	65.0	10.2
55	4.4	18.1	13.8	0.76	0.82	22.0	20.9	64.5	11.0
55	4.6	18.1	13.8	0.76	0.82	22.1	20.9	64.1	11.9
55	5.0	18.1	13.8	0.76	0.81	22.3	20.9	63.4	13.8
68	2.7	17.4	13.5	0.78	1.01	17.2	20.8	83.4	4.4
68	3.3	17.4	13.5	0.78	0.98	17.7	20.8	80.6	6.3
68	3.7	17.5	13.5	0.77	0.97	18.0	20.8	79.2	7.7
68	4.2	17.5	13.5	0.77	0.96	18.2	20.8	77.9	9.7
68	4.4	17.5	13.5	0.77	0.96	18.3	20.7	77.4	10.5
68	4.6	17.5	13.5	0.77	0.95	18.4	20.7	77.0	11.4
68	5.0	17.5	13.5	0.77	0.95	18.5	20.7	76.3	13.2
77	2.7	16.9	13.3	0.79	1.12	15.1	20.7	92.4	4.3
77	3.3	17.0	13.3	0.79	1.09	15.5	20.7	89.5	6.1
77	3.7	17.0	13.3	0.79	1.08	15.7	20.7	88.2	7.5
77	4.2	17.0	13.4	0.79	1.06	16.0	20.6	86.8	9.4
77	4.4	17.0	13.4	0.79	1.06	16.1	20.6	86.4	10.2
77	4.6	17.0	13.4	0.79	1.06	16.1	20.6	86.0	11.0
77	5.0	17.0	13.4	0.79	1.05	16.2	20.6	85.2	12.8
86	2.7	16.4	13.2	0.80	1.24	13.2	20.7	101.3	4.2
86	3.3	16.4	13.2	0.80	1.21	13.6	20.6	98.5	6.0
86	3.7	16.5	13.2	0.80	1.20	13.8	20.5	97.1	7.3
86	4.2	16.5	13.2	0.80	1.18	13.9	20.5	95.8	9.1
86	4.4	16.5	13.2	0.80	1.18	14.0	20.5	95.3	9.9
86	4.6	16.5	13.2	0.80	1.17	14.1	20.5	94.9	10.7
86	5.0	16.5	13.2	0.80	1.17	14.1	20.5	94.2	12.4
95	2.7	15.9	13.0	0.82	1.38	11.5	20.6	110.2	4.1
95	3.3	15.9	13.0	0.82	1.35	11.8	20.5	107.4	5.8
95	3.7	15.9	13.0	0.82	1.33	12.0	20.5	106.1	7.1
95	4.2	15.9	13.0	0.82	1.32	12.1	20.4	104.7	8.9
95	4.4	15.9	13.0	0.82	1.31	12.2	20.4	104.3	9.7
95	4.6	15.9	13.0	0.82	1.31	12.2	20.4	103.9	10.4
95	5.0	15.9	13.0	0.82	1.30	12.3	20.4	103.1	12.1
105	2.7	15.3	12.8	0.84	1.55	9.9	20.6	120.2	4.0
105	3.3	15.3	12.8	0.84	1.51	10.1	20.5	117.4	5.7
105	3.7	15.3	12.8	0.84	1.50	10.2	20.4	116.0	6.9
105	4.2	15.3	12.8	0.84	1.48	10.3	20.4	114.7	8.7
105	4.4	15.3	12.8	0.84	1.48	10.4	20.3	114.2	9.4
105	4.6	15.3	12.8	0.84	1.47	10.4	20.3	113.8	10.2
105	5.0	15.3	12.8	0.84	1.46	10.5	20.3	113.1	11.8
115	2.7	14.6	12.6	0.86	1.75	8.4	20.6	130.3	3.9
115	3.3	14.6	12.6	0.86	1.71	8.5	20.5	127.4	5.5
115	3.7	14.6	12.6	0.86	1.70	8.6	20.4	126.0	6.7
115	4.2	14.6	12.6	0.86	1.67	8.7	20.3	124.7	8.4





## Performance Data

**Table 17. Cooling capacities 1.5 tons (net) - GEC018 (continued)**

EWT	GPM	Total Mbtuh	Sen Mbtuh	SHR	Power kW	EER	Reject Mbtuh	LWT	Feet Head
115	4.4	14.6	12.6	0.86	1.67	8.8	20.3	124.2	9.1
115	4.6	14.6	12.6	0.86	1.66	8.8	20.3	123.8	9.9
115	5.0	14.6	12.6	0.86	1.66	8.8	20.3	123.1	11.5
120	2.7	14.3	12.5	0.87	1.87	7.7	20.7	135.3	3.8
120	3.3	14.3	12.5	0.87	1.83	7.8	20.5	132.5	5.4
120	3.7	14.3	12.5	0.87	1.81	7.9	20.5	131.1	6.7
120	4.2	14.3	12.5	0.87	1.79	8.0	20.4	129.7	8.3
120	4.4	14.3	12.5	0.87	1.79	8.0	20.4	129.3	9.0
120	4.6	14.3	12.5	0.87	1.78	8.0	20.4	128.9	9.8
120	5.0	14.3	12.5	0.87	1.77	8.1	20.3	128.1	11.3

**Note:** Cooling performance data is tabulated at 80.6°F DB/66.2°F WB entering air at ARI/ISO 13256-1 rated cfm. For ARI/ISO 13256-1 certified ratings, see [Table 4, p. 21](#). See Performance correction tables to correct performance at conditions other than those tabulated. Data shown is for unit performance only interpolation is permissible. Extrapolation is not. Rated GPM: 4.2 Minimum cfm 460; Rated cfm 530; Maximum cfm 530.

**Table 18. Heating capacities 1.5 tons (net) - GEC018**

EWT	GPM	Htg. Cap Mbtuh	Absorb Mbtuh	Power kW	COP	LWT	Feet Head
25	2.7	11.8	8.0	1.10	3.1	19.0	6.6
25	3.3	12.0	8.2	1.10	3.2	20.0	9.4
25	3.7	12.1	8.3	1.10	3.2	20.5	11.4
25	4.2	12.1	8.4	1.10	3.2	21.0	14.3
25	4.4	12.2	8.4	1.10	3.2	21.2	15.5
25	4.6	12.2	8.5	1.11	3.2	21.3	16.7
25	5.0	12.2	8.5	1.10	3.2	21.6	19.3
32	2.7	12.9	9.1	1.11	3.4	25.3	6.4
32	3.3	13.1	9.3	1.12	3.4	26.4	9.1
32	3.7	13.2	9.4	1.12	3.5	26.9	11.1
32	4.2	13.3	9.5	1.12	3.5	27.5	13.8
32	4.4	13.3	9.5	1.12	3.5	27.7	15.0
32	4.6	13.3	9.5	1.12	3.5	27.9	16.2
32	5.0	13.4	9.6	1.12	3.5	28.2	18.7
45	2.7	15.3	11.4	1.14	3.9	36.5	5.2
45	3.3	15.6	11.7	1.15	4.0	37.9	7.3
45	3.7	15.7	11.8	1.15	4.0	38.6	8.9
45	4.2	15.8	11.9	1.15	4.0	39.3	11.1
45	4.4	15.8	11.9	1.15	4.0	39.6	12.1
45	4.6	15.8	11.9	1.15	4.0	39.8	13.0
45	5.0	15.9	12.0	1.15	4.1	40.2	15.1
55	2.7	17.2	13.2	1.17	4.3	45.2	5.0
55	3.3	17.4	13.4	1.17	4.4	46.9	7.0
55	3.7	17.6	13.6	1.17	4.4	47.7	8.6
55	4.2	17.8	13.8	1.18	4.4	48.4	10.7
55	4.4	17.8	13.8	1.18	4.4	48.7	11.6
55	4.6	17.8	13.8	1.17	4.5	49.0	12.5
55	5.0	17.9	13.9	1.17	4.5	49.4	14.5
68	2.7	19.7	15.6	1.20	4.8	56.4	4.7

**Table 18. Heating capacities 1.5 tons (net) - GEC018 (continued)**

EWT	GPM	Htg. Cap Mbtuh	Absorb Mbtuh	Power kW	COP	LWT	Feet Head
68	3.3	20.1	16.0	1.20	4.9	58.3	6.7
68	3.7	20.2	16.1	1.20	4.9	59.3	8.2
68	4.2	20.4	16.3	1.21	5.0	60.3	10.2
68	4.4	20.4	16.3	1.21	5.0	60.6	11.1
68	4.6	20.5	16.4	1.21	5.0	60.9	11.9
68	5.0	20.6	16.5	1.21	5.0	61.4	13.8
75	2.7	21.1	16.9	1.22	5.1	62.5	4.6
75	3.3	21.5	17.3	1.22	5.1	64.5	6.6
75	3.7	21.7	17.5	1.23	5.2	65.5	8.0
75	4.2	21.9	17.7	1.23	5.2	66.6	10.0
75	4.4	21.9	17.7	1.23	5.2	66.9	10.8
75	4.6	22.0	17.8	1.23	5.2	67.3	11.7
75	5.0	22.1	17.9	1.23	5.3	67.8	13.5
86	2.7	23.3	19.0	1.25	5.4	71.9	4.5
86	3.3	23.8	19.5	1.26	5.5	74.2	6.3
86	3.7	24.0	19.6	1.26	5.5	75.4	7.7
86	4.2	24.2	19.9	1.27	5.6	76.5	9.6
86	4.4	24.2	19.9	1.27	5.6	77.0	10.4
86	4.6	24.3	20.0	1.27	5.6	77.3	11.3
86	5.0	24.4	20.1	1.27	5.6	78.0	13.0

**Note:** Heating performance data is tabulated at 68°F DB entering air at AHRI/ISO 13256-1 rated CFM. For AHRI/ISO 13256-1 certified ratings, see [Table 4, p. 21](#). See Performance correction tables to correct performance at conditions other than those tabulated. Data shown is for unit performance only. Interpolation is permissible. Extrapolation is not. Rated GPM: 4.2 Minimum cfm 460; Rated cfm 530; Maximum cfm 530.

**Table 19. Fan correction factory 1.5 tons - GEC018**

Entering cfm	Cooling Capacity	Sensible Capacity	Cooling Input Watts	Heating Capacity	Heating Input Watts
460	0.974	0.916	1.002	0.993	1.050
530	1.000	1.000	1.000	1.000	1.000

**Table 20. Correction factors for variation in entering air temperature 0.5 tons, GEC006**

Cooling Entering Air WB°F	Cooling Capacity	Cooling Input Watts	Sensible vs. Entering Dry Bulb Multipliers					Heating Entering Air DB°F	Heating Capacity	Heating Input Watts
			65.6	70.6	75.6	80.6	85.6			
49.4	0.962	1.012	0.958	1.019	1.079	*	*	53.0	1.023	0.863
56.3	0.963	1.015	0.817	1.020	1.078	*	*	58.0	1.018	0.906
60.3	0.961	1.012	0.603	0.845	1.059	*	*	63.0	1.008	0.951
63.2	0.970	1.011	0.438	0.687	0.927	1.134	*	68.0	1.000	1.000
66.2	1.000	1.000	—	0.518	0.762	1.000	1.197	73.0	0.991	1.051
72.1	1.062	0.975	—	—	0.424	0.670	0.911	78.0	0.982	1.107
77.1	1.134	0.965	—	—	—	0.380	0.589	83.0	0.975	1.164

**Note:** \* = Sensible equals total capacity.



## Performance Data

**Table 21. Correction factors for variation in entering air temperature 0.75 tons, GEC009**

Cooling Entering Air WB°F	Cooling Capacity	Cooling Input Watts	Sensible vs. Entering Dry Bulb Multipliers					Heating Entering Air DB°F	Heating Capacity	Heating Input Watts
			65.6	70.6	75.6	80.6	85.6			
49.4	0.956	1.032	0.940	1.003	1.067	*	*	53.0	1.038	0.872
56.3	0.956	1.033	0.802	1.016	1.066	*	*	58.0	1.024	0.911
60.3	0.956	1.033	0.573	0.838	1.072	*	*	63.0	1.012	0.953
63.2	0.968	1.026	0.417	0.675	0.925	1.135	*	68.0	1.000	1.000
66.2	1.000	1.000	—	0.542	0.774	1.000	1.195	73.0	0.989	1.050
72.1	1.087	0.974	—	—	0.607	0.764	0.977	78.0	0.980	1.104
77.1	1.173	0.949	—	—	—	0.476	0.712	83.0	0.970	1.163

Note: \* = Sensible equals total capacity.

**Table 22. Correction factors for variation in entering air temperature 1 tons, GEC012**

Cooling Entering Air WB°F	Cooling Capacity	Cooling Input Watts	Sensible vs. Entering Dry Bulb Multipliers					Heating Entering Air DB°F	Heating Capacity	Heating Input Watts
			65.6	70.6	75.6	80.6	85.6			
49.4	0.973	1.007	0.993	1.051	1.109	*	*	53.0	1.014	0.847
56.3	0.973	1.007	0.818	1.055	1.109	*	*	58.0	1.010	0.896
60.3	0.972	1.007	0.576	0.837	1.099	*	*	63.0	1.004	0.946
63.2	0.977	1.003	0.396	0.659	0.923	1.169	*	68.0	1.000	1.000
66.2	1.000	1.000	—	0.473	0.731	1.000	1.227	73.0	0.994	1.057
72.1	1.043	0.971	—	—	0.365	0.617	0.867	78.0	0.990	1.119
77.1	1.105	0.969	—	—	—	0.299	0.558	83.0	0.983	1.185

Note: \* = Sensible equals total capacity.

**Table 23. Correction factors for variation in entering air temperature 1.25 tons, GEC015**

Cooling Entering Air WB°F	Cooling Capacity	Cooling Input Watts	Sensible vs. Entering Dry Bulb Multipliers					Heating Entering Air DB°F	Heating Capacity	Heating Input Watts
			65.6	70.6	75.6	80.6	85.6			
49.4	0.952	1.038	0.999	1.058	1.118	*	*	53.0	1.023	0.832
56.3	0.951	1.040	0.834	1.016	1.117	*	*	58.0	1.016	0.887
60.3	0.951	1.040	0.637	0.871	1.055	*	*	63.0	1.010	0.944
63.2	0.970	1.021	0.481	0.715	0.937	1.112	*	68.0	1.000	1.000
66.2	1.000	1.000	—	0.556	0.786	1.000	1.166	73.0	0.992	1.058
72.1	1.062	0.953	—	—	0.485	0.696	0.924	78.0	0.981	1.120
77.1	1.143	0.926	—	—	—	0.452	0.665	83.0	0.970	1.179

Note: \* = Sensible equals total capacity.

**Table 24. Correction factors for variation in entering air temperature 1.5 tons, GEC018**

Cooling Entering Air WB°F	Cooling Capacity	Cooling Input Watts	Sensible vs. Entering Dry Bulb Multipliers					Heating Entering Air DB°F	Heating Capacity	Heating Input Watts
			65.6	70.6	75.6	80.6	85.6			
49.4	0.947	1.009	0.995	1.056	1.119	*	*	53.0	1.025	0.855
56.3	0.946	1.009	0.823	1.036	1.118	*	*	58.0	1.018	0.901
60.3	0.945	1.009	0.632	0.852	1.070	*	*	63.0	1.009	0.949
63.2	0.960	1.006	0.485	0.710	0.928	1.142	*	68.0	1.000	1.000

**Table 24. Correction factors for variation in entering air temperature 1.5 tons, GEC018 (continued)**

Cooling Entering Air WB°F	Cooling Capacity	Cooling Input Watts	Sensible vs. Entering Dry Bulb Multipliers					Heating Entering Air DB°F	Heating Capacity	Heating Input Watts
			65.6	70.6	75.6	80.6	85.6			
66.2	1.000	1.000	—	0.561	0.781	1.000	1.211	73.0	0.992	1.054
72.1	1.086	0.980	—	—	0.481	0.706	0.920	78.0	0.983	1.111
77.1	1.154	0.972	—	—	—	0.443	0.667	83.0	0.976	1.173

Note: \* = Sensible equals total capacity.

**Table 25. Fan performance**

Unit	Min CFM	Max CFM
GEC006 Low	220	220
GEC006 High	290	290
GEC009 Low	240	240
GEC009 High	305	305
GEC012 Low	360	360
GEC012 High	430	430
GEC015 Low	400	400
GEC015 High	480	480
GEC018 Low	460	460
GEC018 High	530	530

**Table 26. Antifreeze correction factors**

Methanol (concentration by volume)						
Item	0%	10%	20%	30%	40%	50%
Cooling Capacity	1.000	0.998	0.997	0.995	0.993	0.992
Heating Capacity	1.000	0.995	0.990	0.985	0.979	0.974
Pressure Drop	1.000	1.023	1.057	1.091	1.122	1.160
Ethylene Glycol (concentration by volume)						
Item	0%	10%	20%	30%	40%	50%
Cooling Capacity	1.000	0.996	0.991	0.987	0.983	0.979
Heating Capacity	1.000	0.993	0.985	0.977	0.969	0.961
Pressure Drop	1.000	1.024	1.068	1.124	1.188	1.263
Propylene Glycol (concentration by volume)						
Item	0%	10%	20%	30%	40%	50%
Cooling Capacity	1.000	0.993	0.987	0.980	0.974	0.968
Heating Capacity	1.000	0.986	0.973	0.960	0.948	0.935
Pressure Drop	1.000	1.040	1.098	1.174	1.273	1.405
Brine (NaCL) (concentration by volume)						
Item	0%	10%	20%	30%	40%	50%
Cooling Capacity	1.000	0.994	0.987	0.979	0.971	0.963
Heating Capacity	1.000	0.993	0.987	0.982	0.978	0.976
Pressure Drop	1.000	1.154	1.325	1.497	1.669	1.841

Examples

Figure 21. Cooling capacity correction factor

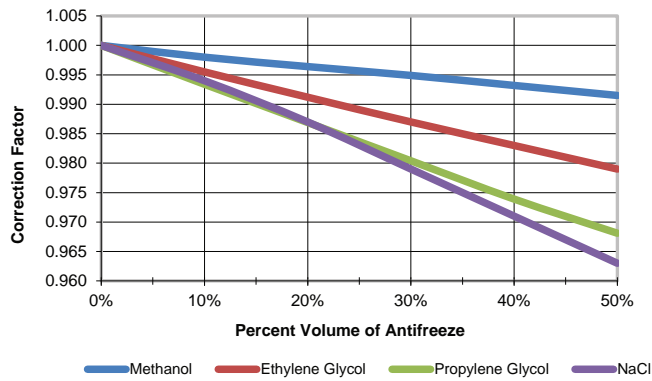

Figure 22. Heating capacity correction factor

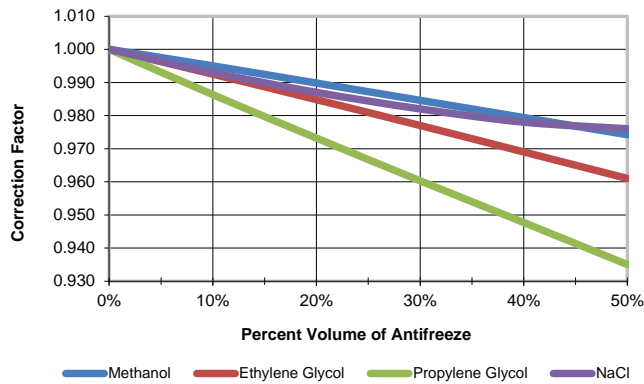
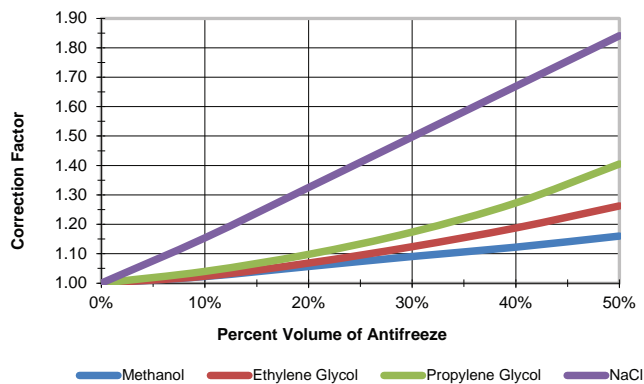

Figure 23. Water pressure drop correction factor





**Example 1 (Ethylene Glycol)** - The antifreeze solution is 20% by volume of Ethylene Glycol. Determine the corrected cooling capacity and waterside pressure drop for a GEC 018 when the EWT is 86°F and the GPM is 4.2.

From the catalog data, the cooling capacity at these conditions with 100% water is 17.0 MBtuh, and the waterside pressure drop is 8.9 feet of head. At 20% Ethylene Glycol, the correction factor for cool capacity is 0.9912 and the pressure drop is 1.068.

The corrected cooling capacity (MBtuh) =  $17.0 * 0.9912 = 16.9$ . The corrected water side pressure drop (Ft. head) =  $8.9 * 1.068 = 9.5$ .

**Example 2 (Propylene Glycol)** - The antifreeze solution is 30% by volume of Propylene Glycol. Determine the corrected heating capacity and waterside pressure drop for a GEC 012 when the EWT is 45°F and the GPM is 2.8.

From the catalog data, the heating capacity at these conditions with 100% water is 11.6 MBtuh, and the waterside pressure drop is 8.7 feet of head. At 30% Propylene Glycol, the correction factor for heat capacity is 0.9603 and the pressure drop is 1.174.

The corrected cooling capacity (MBtuh) =  $11.6 * 0.9603 = 11.1$ . The corrected water side pressure drop (ft. head) =  $8.7 * 1.174 = 10.2$ .



# Electrical Data

**Table 27. Electrical data (0.5 to 1.5 tons)**

Model	Volts	Total Unit FLA	Comp RLA (ea)	Compl RA (ea)	No. of Comp	Cmp MCC	Blower Motor FLA	Blower Motor hp	Fan Motors	Minimum Circuit Ampacity	Maximum Overcurrent Protective Device	Electric Heat kW	Electric Heat Amps
GEC006	115/60/1	6.5	5.6	30.0	1	7.5	0.90	1/30	1	7.9	15	0.0	0.0
GEC006	208/60/1	4.1	3.3	14.0	1	4.2	0.80	1/30	1	4.9	15	0.0	0.0
GEC006	208/60/1	11.6	3.3	14.0	1	4.2	0.80	1/30	1	14.5	15	2.25	10.82
GEC006	208/60/1	15.2	3.3	14.0	1	4.2	0.80	1/30	1	19.0	20	3.0	14.42
GEC006	230/60/1	3.9	3.2	15.0	1	4.2	0.70	1/30	1	4.7	15	0.0	0.0
GEC006	230/60/1	12.7	3.2	15.0	1	4.2	0.70	1/30	1	15.8	20	2.75	11.96
GEC006	220-240/50/1	3.6	2.9	17.0	1	4.0	0.70	1/30	1	4.3	15	0.0	0.0
GEC006	220-240/50/1	13.2	2.9	17.0	1	4.0	0.70	1/30	1	16.5	20	3.0	12.5
GEC006	265/60/1	3.2	2.5	11.0	1	3.5	0.70	1/20	1	3.8	15	0.0	0.0
GEC006	265/60/1	11.1	2.5	11.0	1	3.5	0.70	1/20	1	13.9	15	2.75	10.38
GEC009	115/60/1	7.3	6.4	36.0	1	8.6	0.90	1/30	1	8.9	15	0.0	0.0
GEC009	208/60/1	4.5	3.7	16.0	1	4.8	0.80	1/30	1	5.4	15	0.0	0.0
GEC009	208/60/1	11.6	3.7	16.0	1	4.8	0.80	1/30	1	14.5	15	2.25	10.82
GEC009	208/60/1	15.2	3.7	16.0	1	4.8	0.80	1/30	1	19.0	20	3.0	14.42
GEC009	230/60/1	4.2	3.5	17.0	1	4.8	0.70	1/30	1	5.1	15	0.0	0.0
GEC009	230/60/1	12.7	3.5	17.0	1	4.8	0.70	1/30	1	15.8	20	2.75	11.96
GEC009	230/60/1	16.8	3.5	17.0	1	4.8	0.70	1/30	1	21.0	25	3.7	16.09
GEC009	220-240/50/1	6	5.3	23.0	1	7.4	0.70	1/12	1	7.3	15	0.0	0.0
GEC009	220-240/50/1	13.2	5.3	23.0	1	7.4	0.70	1/12	1	16.5	20	3.0	12.5
GEC009	220-240/50/1	17.4	5.3	23.0	1	7.4	0.70	1/12	1	21.7	25	4.0	16.67
GEC009	265/60/1	3.5	2.8	13.0	1	3.7	0.70	1/30	1	4.2	15	0.0	0.0
GEC009	265/60/1	11	2.8	13.0	1	3.7	0.70	1/30	1	13.8	15	2.74	10.34
GEC009	265/60/1	14.7	2.8	13.0	1	3.7	0.70	1/30	1	18.3	20	3.7	13.96
GEC012	115/60/1	13.3	12.1	58.0	1	16.9	1.20	1/12	1	16.3	25	0.0	0.0
GEC012	208/60/1	7.2	6.3	30.0	1	8.8	0.90	1/12	1	8.8	15	0.0	0.0
GEC012	208/60/1	11.7	6.3	30.0	1	8.8	0.90	1/12	1	14.7	15	2.25	10.82
GEC012	208/60/1	15.3	6.3	30.0	1	8.8	0.90	1/12	1	19.2	20	3.0	14.42
GEC012	230/60/1	7	6.3	30.0	1	8.8	0.70	1/12	1	8.6	15	0.0	0.0
GEC012	230/60/1	12.7	6.3	30.0	1	8.8	0.70	1/12	1	15.8	20	2.75	11.96
GEC012	230/60/1	16.8	6.3	30.0	1	8.8	0.70	1/12	1	21.0	25	3.7	16.09
GEC012	220-240/50/1	7.4	6.7	30.0	1	9.4	0.70	1/12	1	9.1	15	0.0	0.0
GEC012	220-240/50/1	13.2	6.7	30.0	1	9.4	0.70	1/12	1	16.5	20	3.0	12.5
GEC012	220-240/50/1	17.4	6.7	30.0	1	9.4	0.70	1/12	1	21.7	25	4.0	16.67
GEC012	265/60/1	5.7	5.0	23.0	1	7.0	0.70	1/12	1	7.0	15	0.0	0.0
GEC012	265/60/1	11.0	5.0	23.0	1	7.0	0.70	1/12	1	13.8	15	2.74	10.34
GEC012	265/60/1	14.7	5.0	23.0	1	7.0	0.70	1/12	1	18.3	20	3.7	13.96
GEC015	115/60/1	16.1	14.9	60.0	1	20.9	1.20	1/12	1	19.8	30	0.0	0.0
GEC015	208/60/1	8.9	7.9	36.0	1	11.1	1.00	1/12	1	10.9	15	0.0	0.0
GEC015	208/60/1	11.8	7.9	36.0	1	11.1	1.00	1/12	1	14.8	15	2.25	10.82
GEC015	208/60/1	15.4	7.9	36.0	1	11.1	1.00	1/12	1	19.3	20	3.0	14.42
GEC015	230/60/1	8.8	7.9	36.0	1	11.1	0.90	1/12	1	10.8	15	0.0	0.0

**Table 27. Electrical data (0.5 to 1.5 tons) (continued)**

Model	Volts	Total Unit FLA	Comp RLA (ea)	CompL RA (ea)	No. of Comp	Cmp MCC	Blower Motor FLA	Blower Motor hp	Fan Motors	Minimum Circuit Ampacity	Maximum Overcurrent Protective Device	Electric Heat kW	Electric Heat Amps
GEC015	230/60/1	12.9	7.9	36.0	1	11.1	0.90	1/12	1	16.1	20	2.76	12.0
GEC015	230/60/1	17	7.9	36.0	1	11.1	0.90	1/12	1	21.2	25	3.7	16.09
GEC015	220-240/50/1	8.6	7.9	28.0	1	11.1	0.70	1/12	1	10.6	15	0.0	0.0
GEC015	220-240/50/1	13.2	7.9	28.0	1	11.1	0.70	1/6	1	16.5	20	3.0	12.5
GEC015	220-240/50/1	17.4	7.9	28.0	1	11.1	0.70	1/6	1	21.7	25	4.0	16.67
GEC015	265/60/1	7.1	6.4	30.0	1	9.0	0.70	1/6	1	8.7	15	0.0	0.0
GEC015	265/60/1	11	6.4	30.0	1	9.0	0.70	1/12	1	13.8	15	2.74	10.34
GEC015	265/60/1	14.7	6.4	30.0	1	9.0	0.70	1/12	1	18.3	20	3.7	13.96
GEC018	208/60/1	10.0	9.0	30.0	1	12.6	1.00	1/6	1	12.3	20	0.0	0.0
GEC018	208/60/1	11.8	9.0	30.0	1	12.6	1.00	1/6	1	14.8	20	2.25	10.82
GEC018	208/60/1	15.4	9.0	30.0	1	12.6	1.00	1/6	1	19.3	20	3.0	14.42
GEC018	230/60/1	9.9	9.0	30.0	1	12.6	0.90	1/6	1	12.2	20	0.0	0.0
GEC018	230/60/1	12.9	9.0	30.0	1	12.6	0.90	1/6	1	16.1	20	2.76	12.0
GEC018	230/60/1	17	9.0	30.0	1	12.6	0.90	1/6	1	21.2	25	3.7	16.09
GEC018	265/60/1	8.5	7.8	30.0	1	10.9	0.70	1/6	1	10.5	15	0.0	0.0
GEC018	265/60/1	11	7.8	30.0	1	10.9	0.70	1/6	1	13.8	15	2.74	10.34
GEC018	265/60/1	14.7	7.8	30.0	1	10.9	0.70	1/6	1	18.3	20	3.7	13.96

**Table 28. Console VA**

Designator	Controls	Deluxe with Reheat (75 VA)	Deluxe with Electric Heat (75 VA)	Symbio™ 400-B/UC400-B (75 VA)	x = ON <sup>(a)</sup>
	Controller	6.0	6.0	12.5	
1K1	Compressor Contactor	5.5	5.5	5.5	X
1K2	Fan Relay	9.5	9.5	9.5	
2L1	Reversing Valve	5.0	5.0	5.0	X
2L2	Reheat Valve	5.0	—	—	
5B3	Damper Actuator	—	—	—	
1K10	Electric Heat Contactor	—	5.5	Optional <sup>(b)</sup>	X
IU3	Boilerless Control Board	—	3.0	N/A	X
	Field Supplied Solenoid	7.0	7.0	7.0	X
1K6, 1K7	Reheat Relays(2)	12.5	—	Optional <sup>(c)</sup>	X
1K8	Reheat Low Speed Relay	—	—	N/A	X
1U1	Thermostat-Unit Mounted	6.0	6.0	N/A	X
	Timer Delay Relay	N/A	N/A	N/A	X
	Total VA	56.5	47.5	39.5	61.40
	Extra VA	18.5	27.5	32.5	13.60

**Note:** Listed VA values are for reference only. Actual values may vary with operating conditions.

- (a) Consider unit options and concurrent loads.
- (b) Electric heat is optional with Symbio™ 400-B/UC400-B controller. If electric heat is selected, add 5.5 VA.
- (c) HGR is optional with the Symbio™ 400-B/UC400-B controller. If HGR is selected, add 12.5 VA.



# Unit Dimensions

## Service Clearances

Access to the unit for servicing purposes should be provided at installation. All configurations require clearance from other mechanical and electrical equipment on three service sides (shown below). This enables panel removal from the unit for service/maintenance ability.

**Figure 24. Clearances - GEC 0.5 to 1.5 tons**

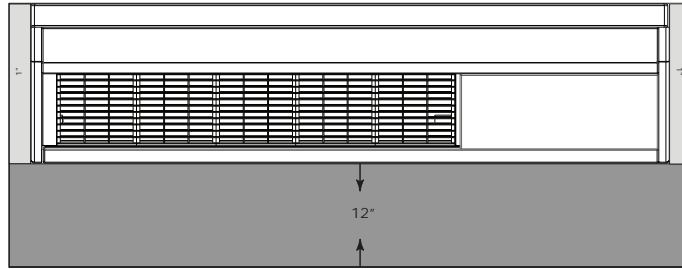

**Figure 25. GEC 0.5 to 1.5 tons (60 Hz), 0.5 to 1.25 tons (50 Hz) - cabinet (RH) piping connection**

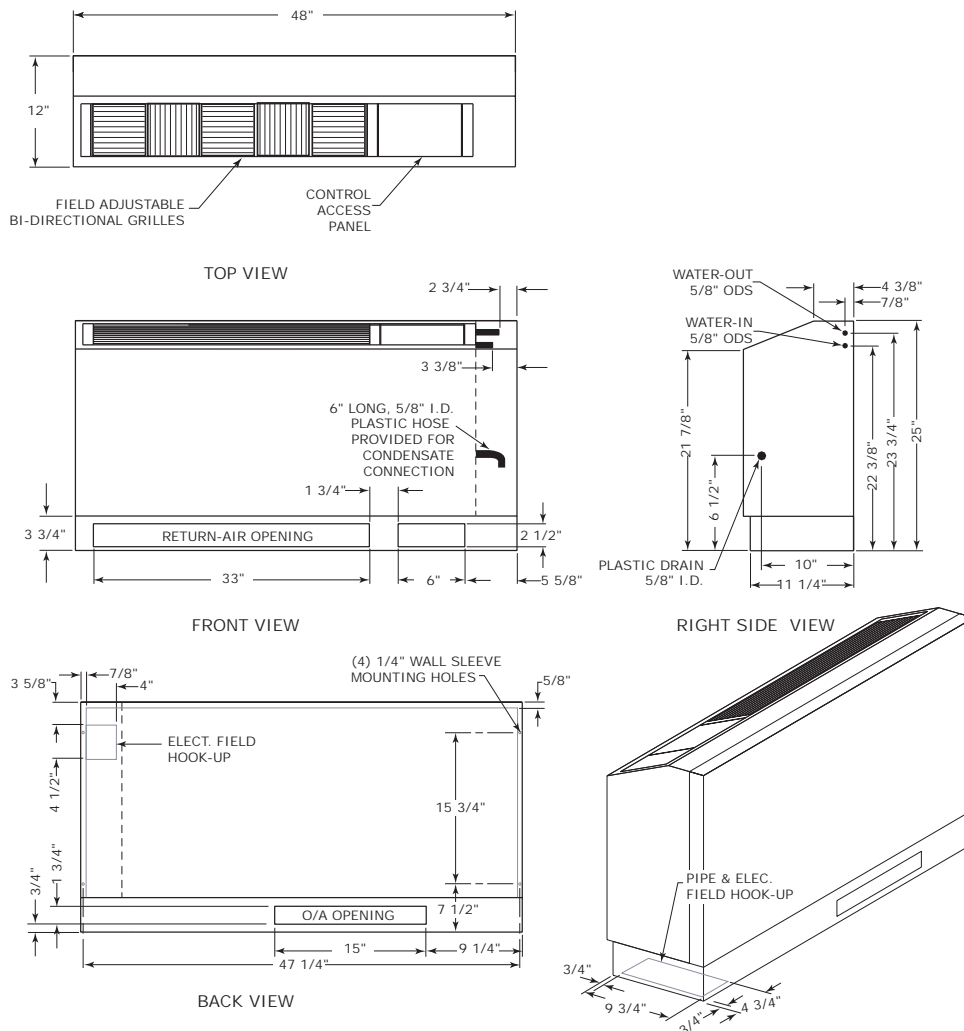

**Figure 26. GEC 0.5 to 1.5 tons (60 Hz), 0.5 to 1.25 tons (50 Hz) - cabinet (LH) piping connection**

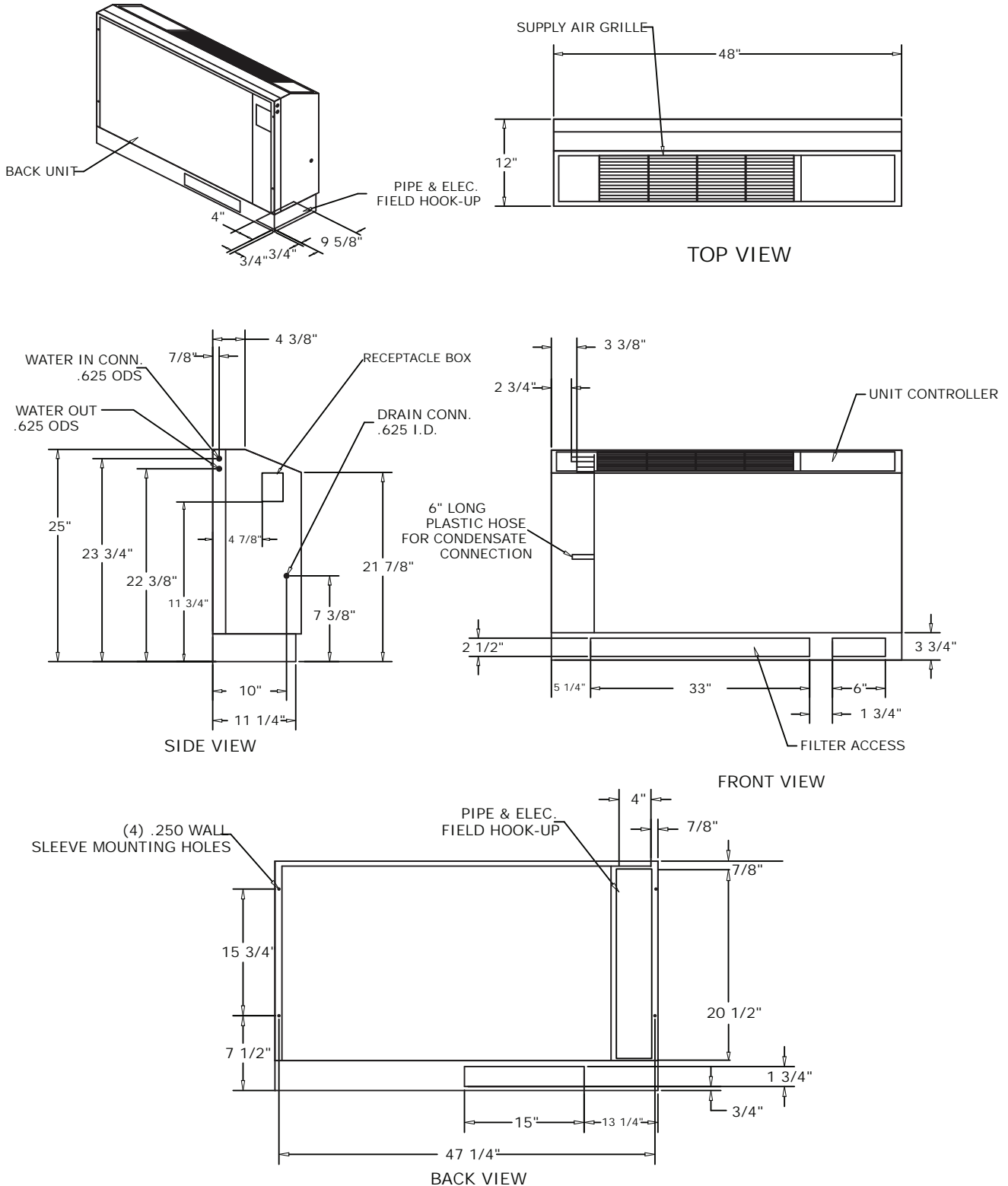



## Unit Dimensions

Figure 27. GEC 0.5 to 1.5 tons (60 Hz), 0.5 to 1.25 tons (50 Hz) - subbase (RH)

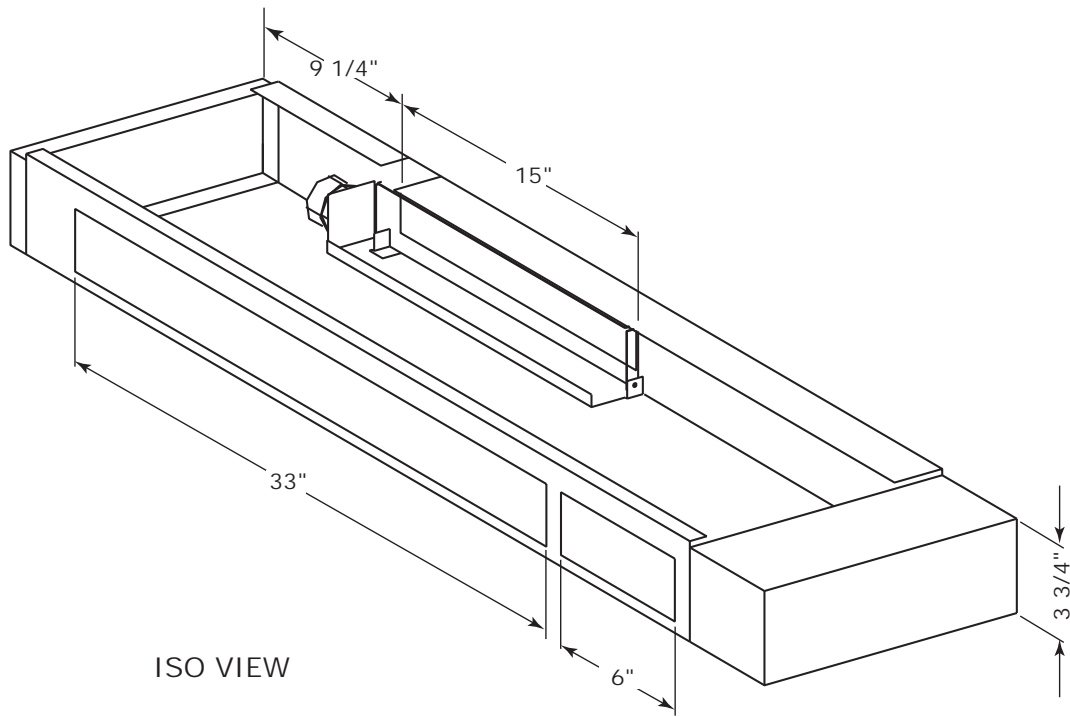
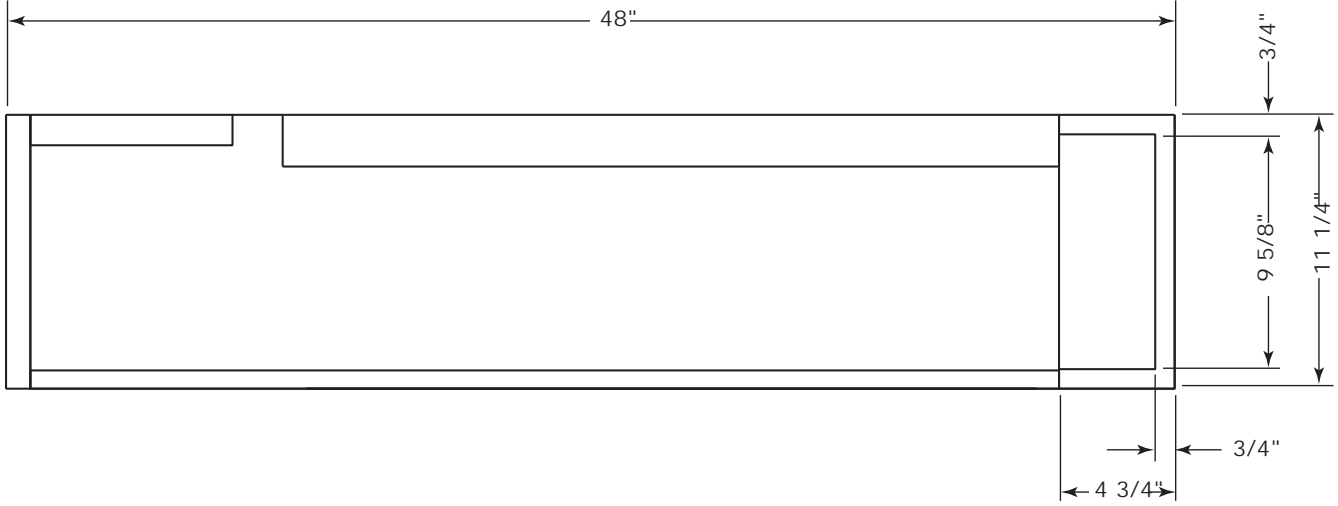
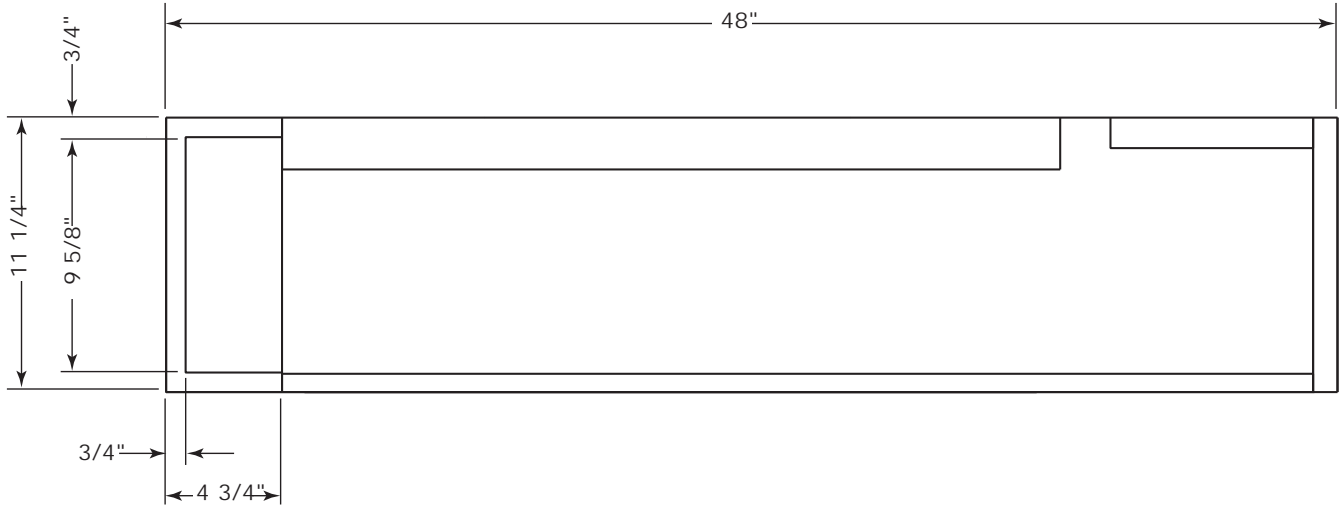
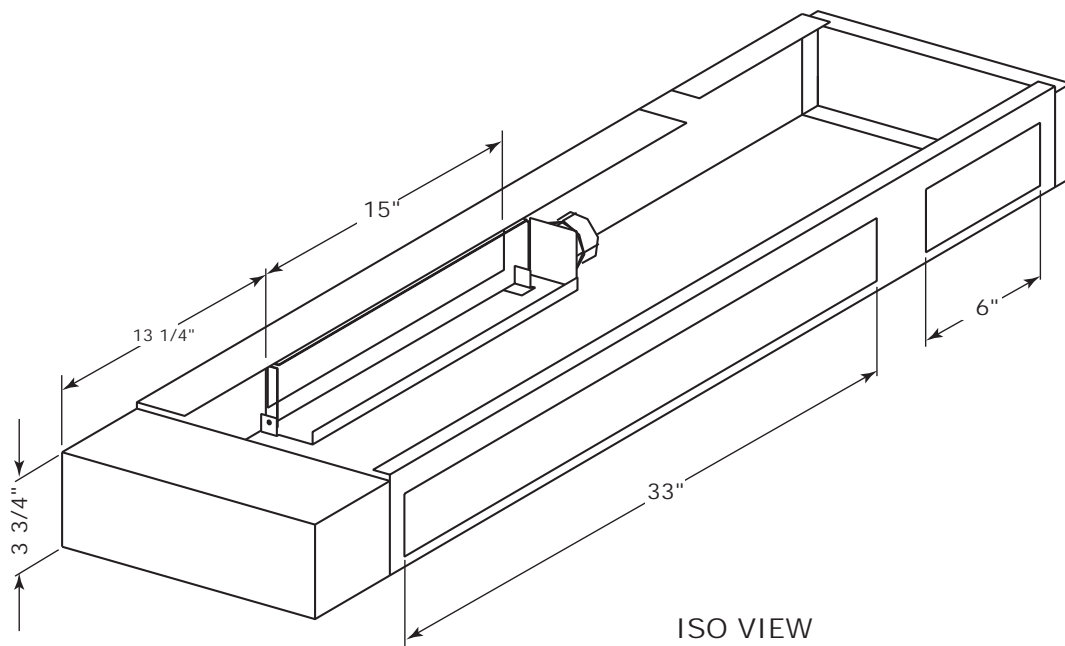

Figure 28. GEC 0.5 to 1.5 tons (60 Hz), 0.5 to 1.25 tons (50 Hz) - subbase (LH)



TOP VIEW



ISO VIEW

## Unit Dimensions

Figure 29. GEC 0.5 to 1.5 tons (60 Hz), 0.5 to 1.25 tons (50 Hz) - cabinet (RH) piping extended length

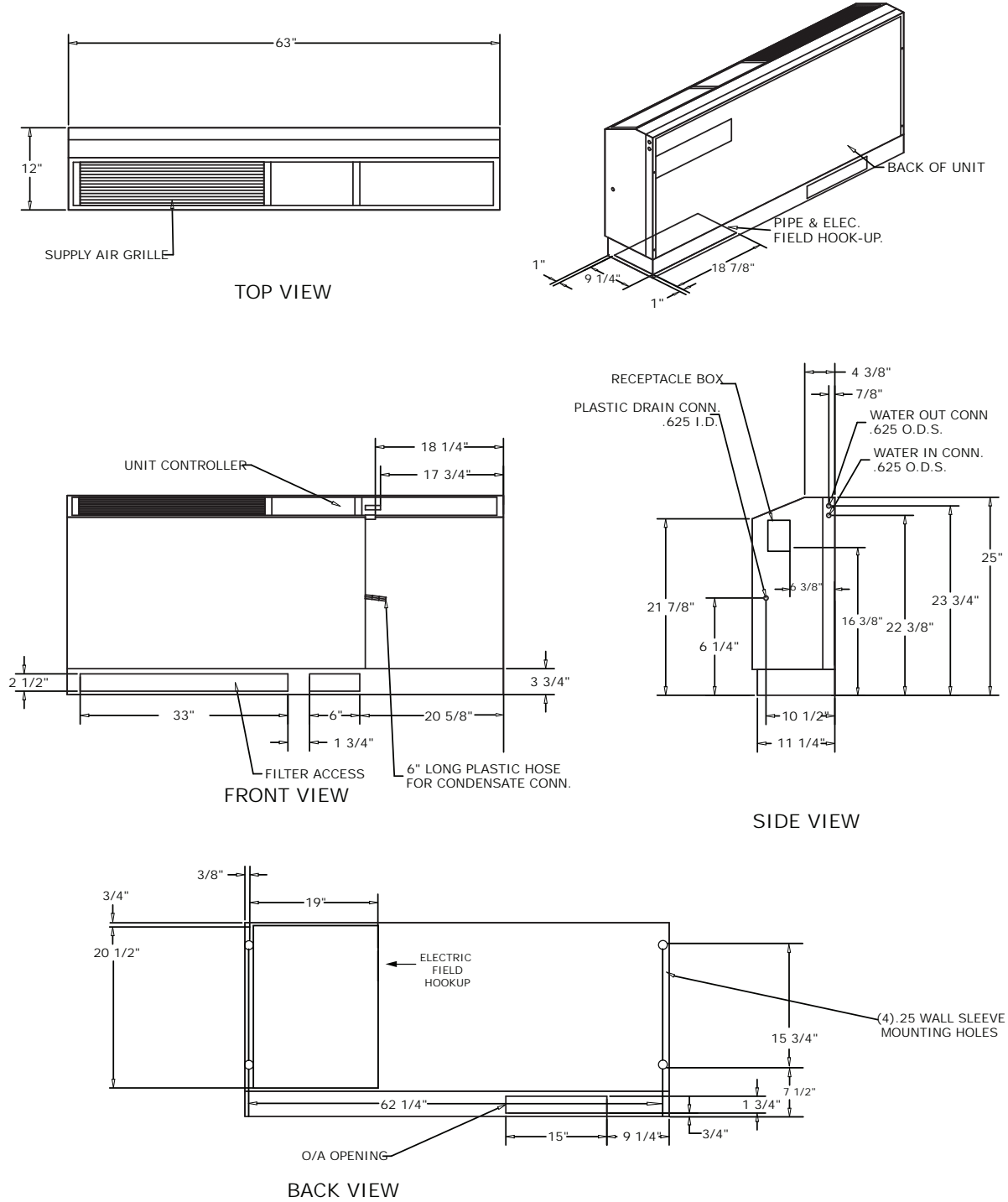
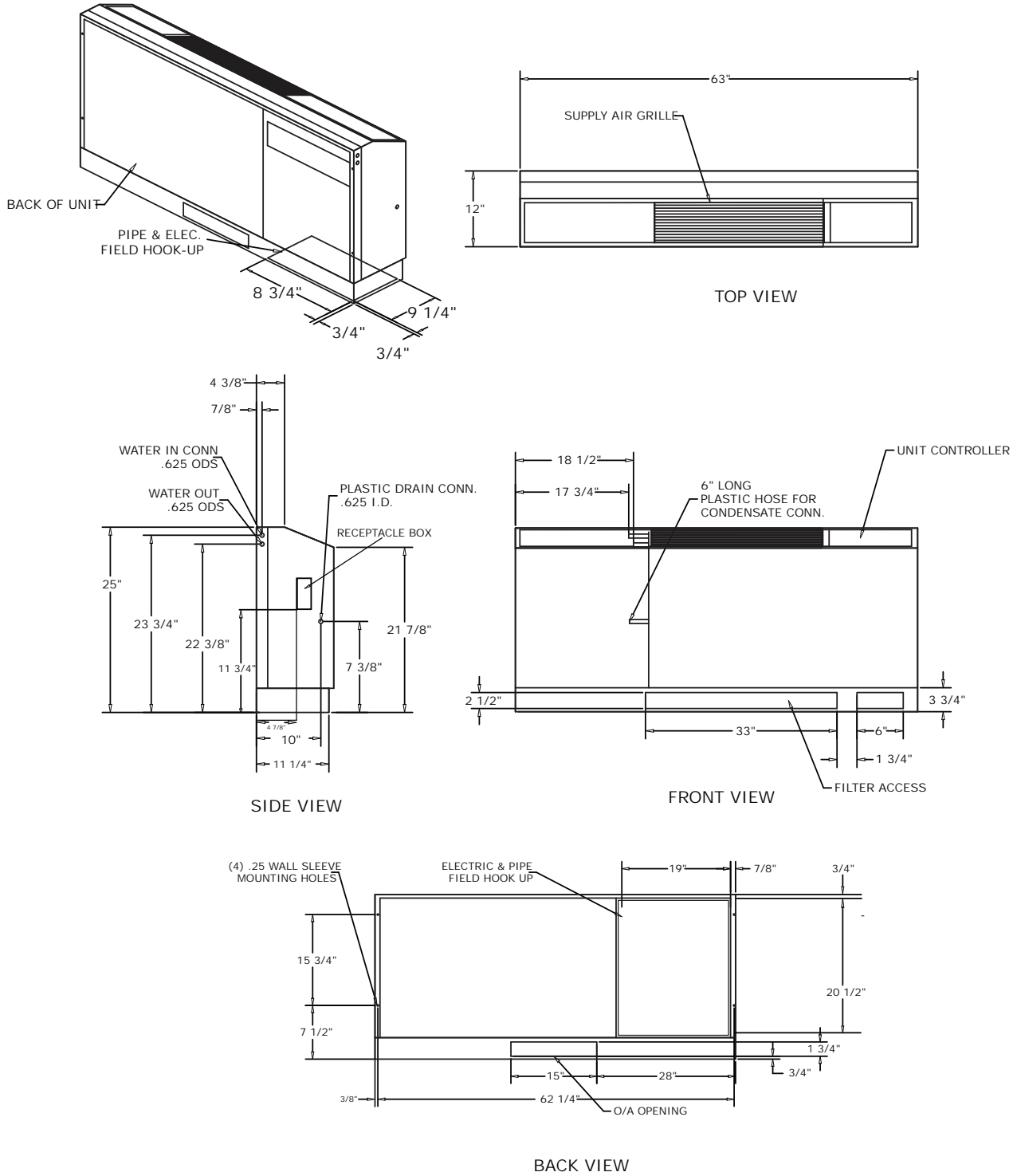

Figure 30. GEC 0.5 to 1.5 tons (60 Hz), 0.5 to 1.25 tons (50 Hz) - cabinet (LH) piping extended length



## Unit Dimensions

Figure 31. GEC 0.5 to 1.5 tons (60 Hz), 0.5 to 1.25 tons (50 Hz) - subbase (RH) extended length

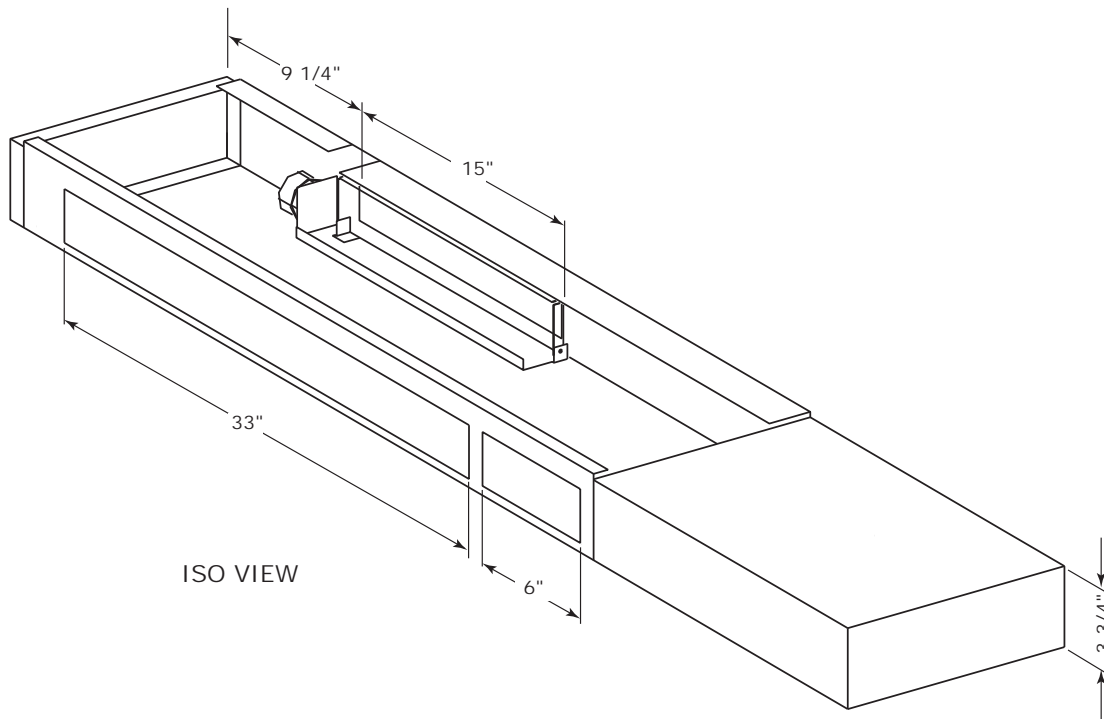
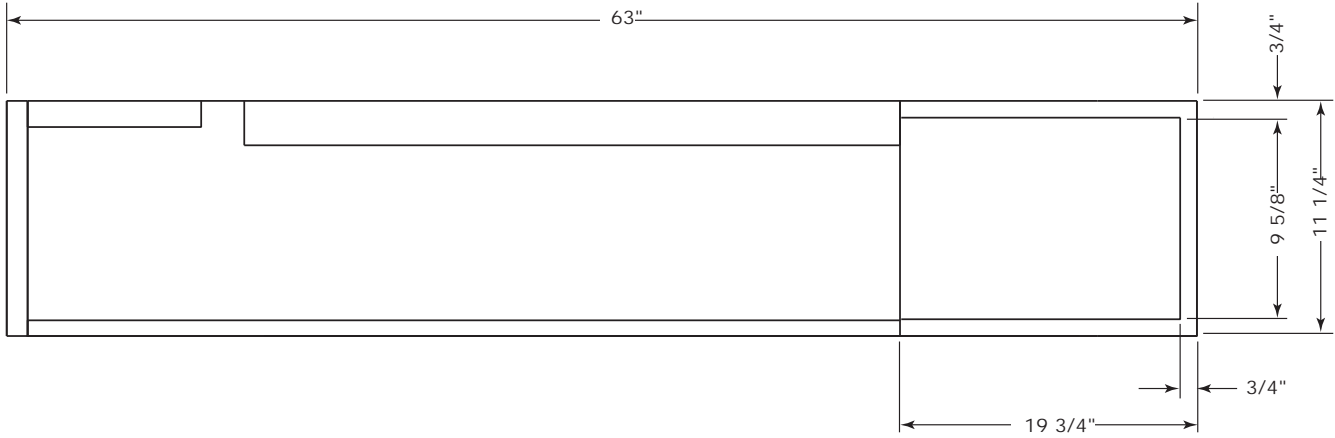
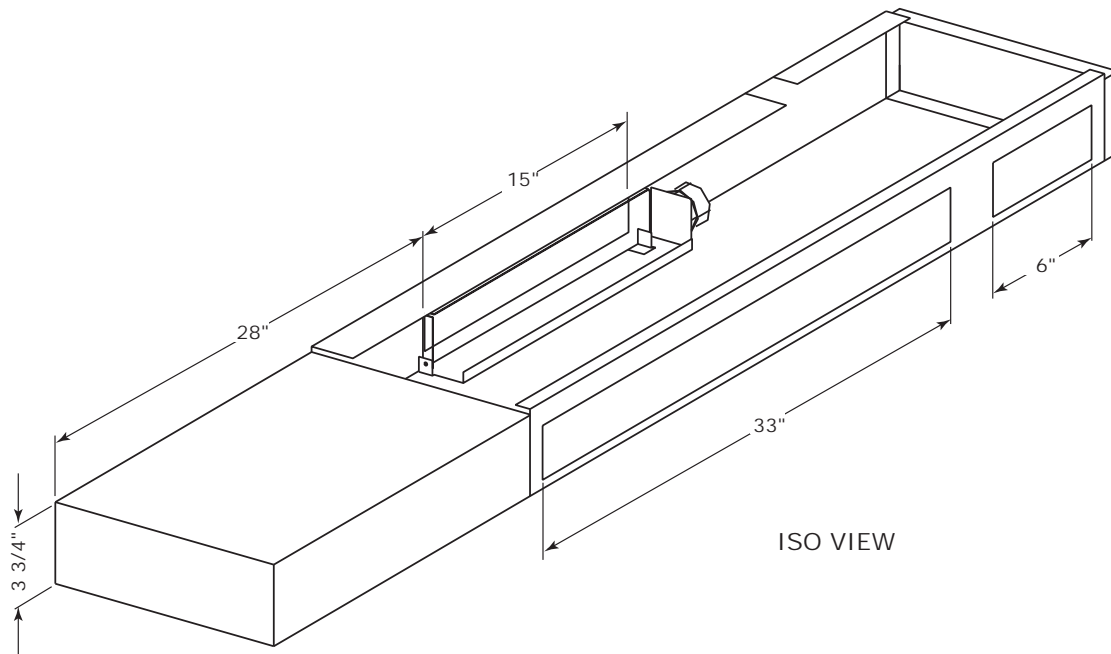
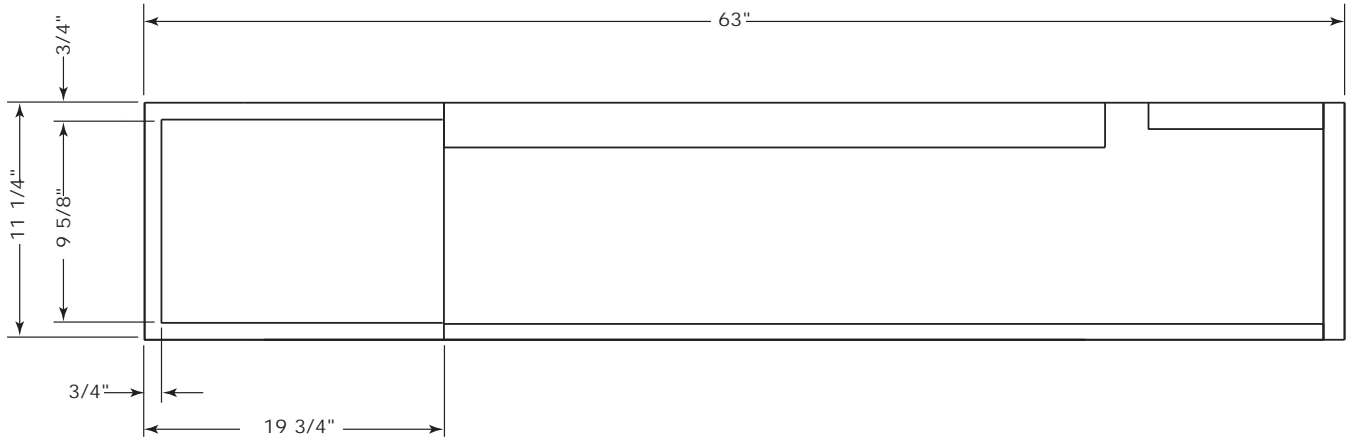



Figure 32. GEC 0.5 to 1.5 tons (60 Hz), 0.5 to 1.25 tons (50 Hz) - subbase (LH) extended length



## Unit Dimensions

Figure 33. GEC 0.5 to 1.5 tons (60 Hz), 0.5 to 1.25 tons (50 Hz) - cabinet (RH) low height unit

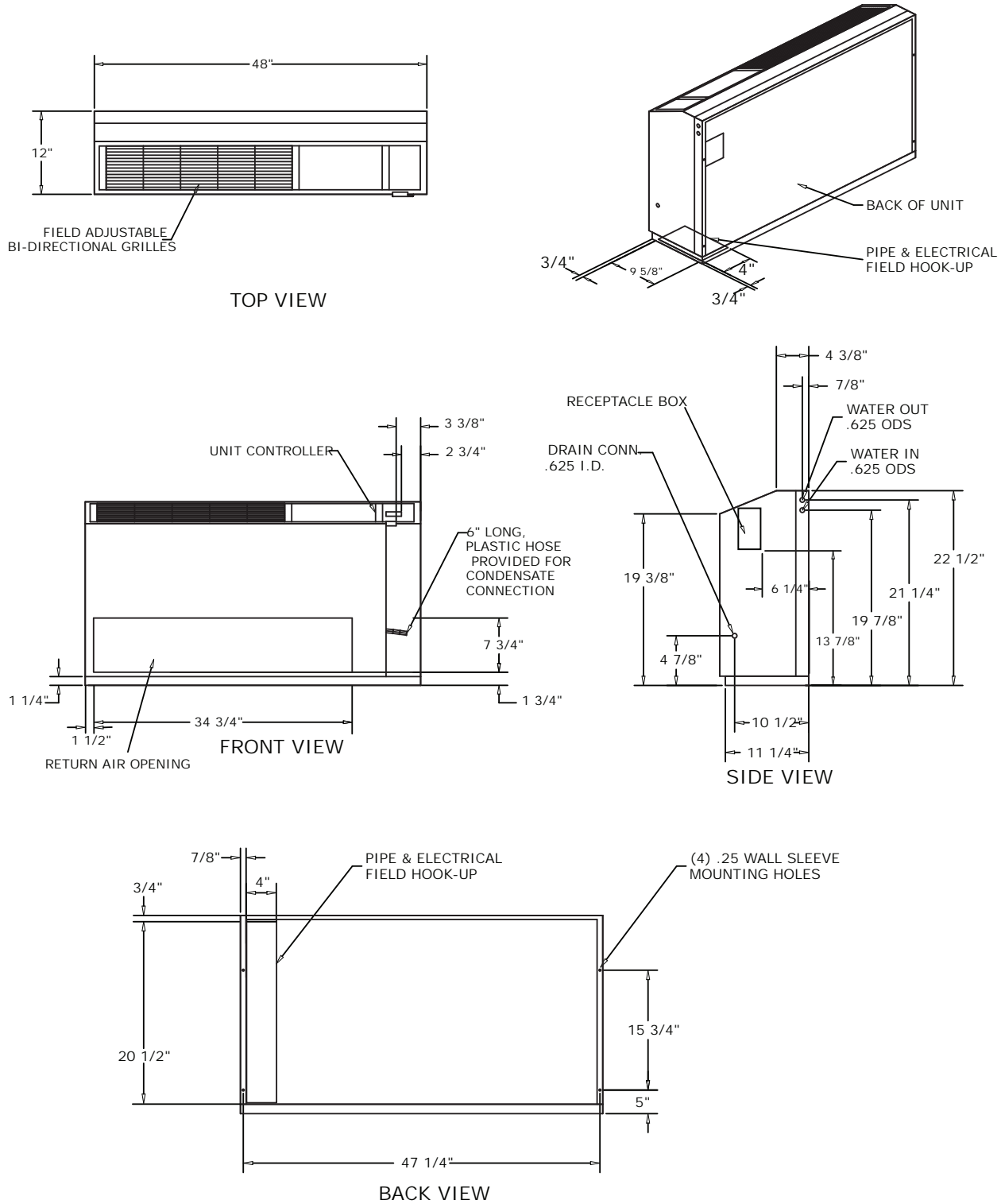
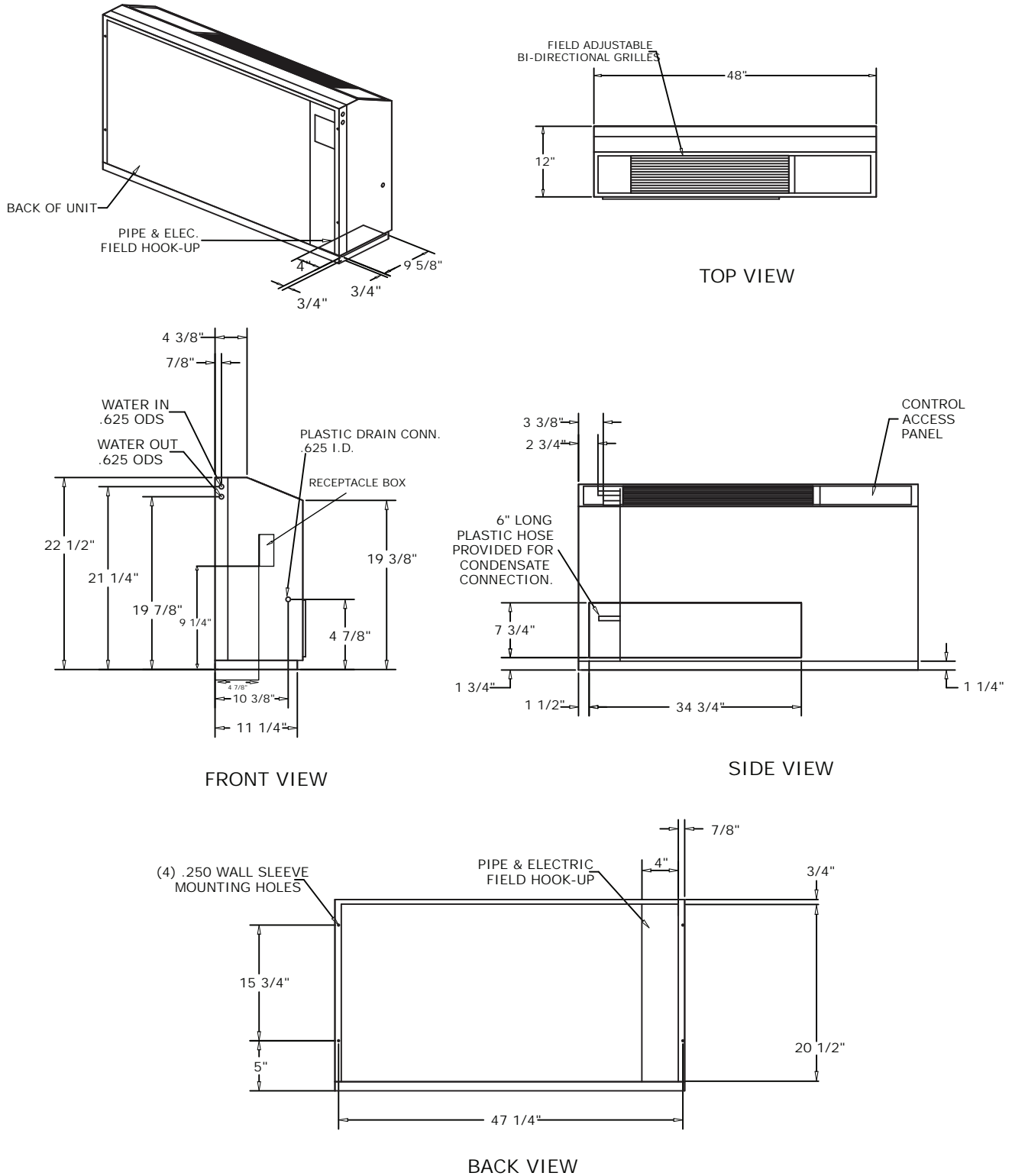

Figure 34. GEC 0.5 to 1.5 tons (60 Hz), 0.5 to 1.25 tons (50 Hz) - cabinet (LH) low height unit



# Unit Dimensions

**Figure 35. GEC 0.5 to 1.5 tons (60 Hz), 0.5 to 1.25 tons (50 Hz) - chassis (RH)**

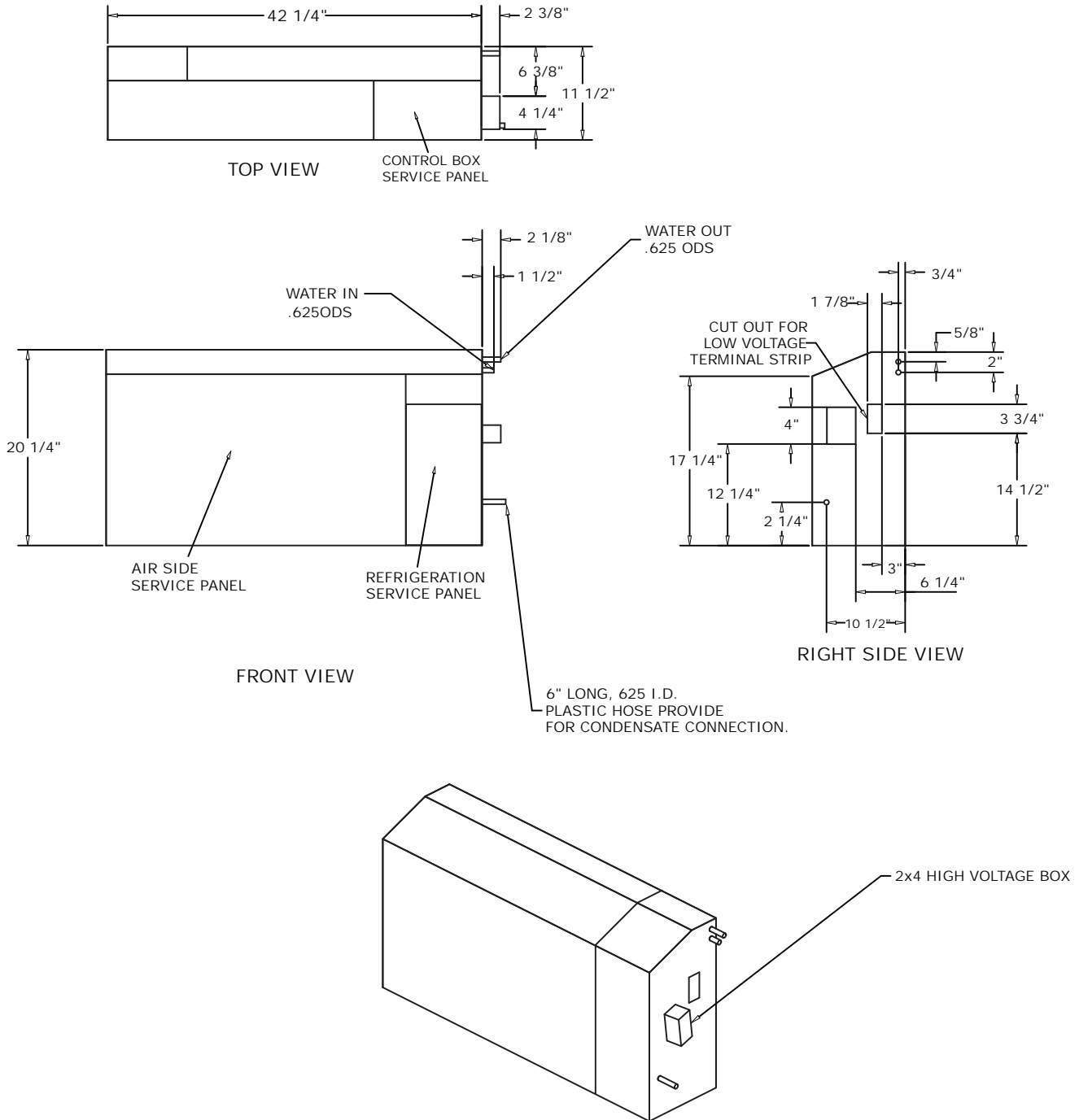
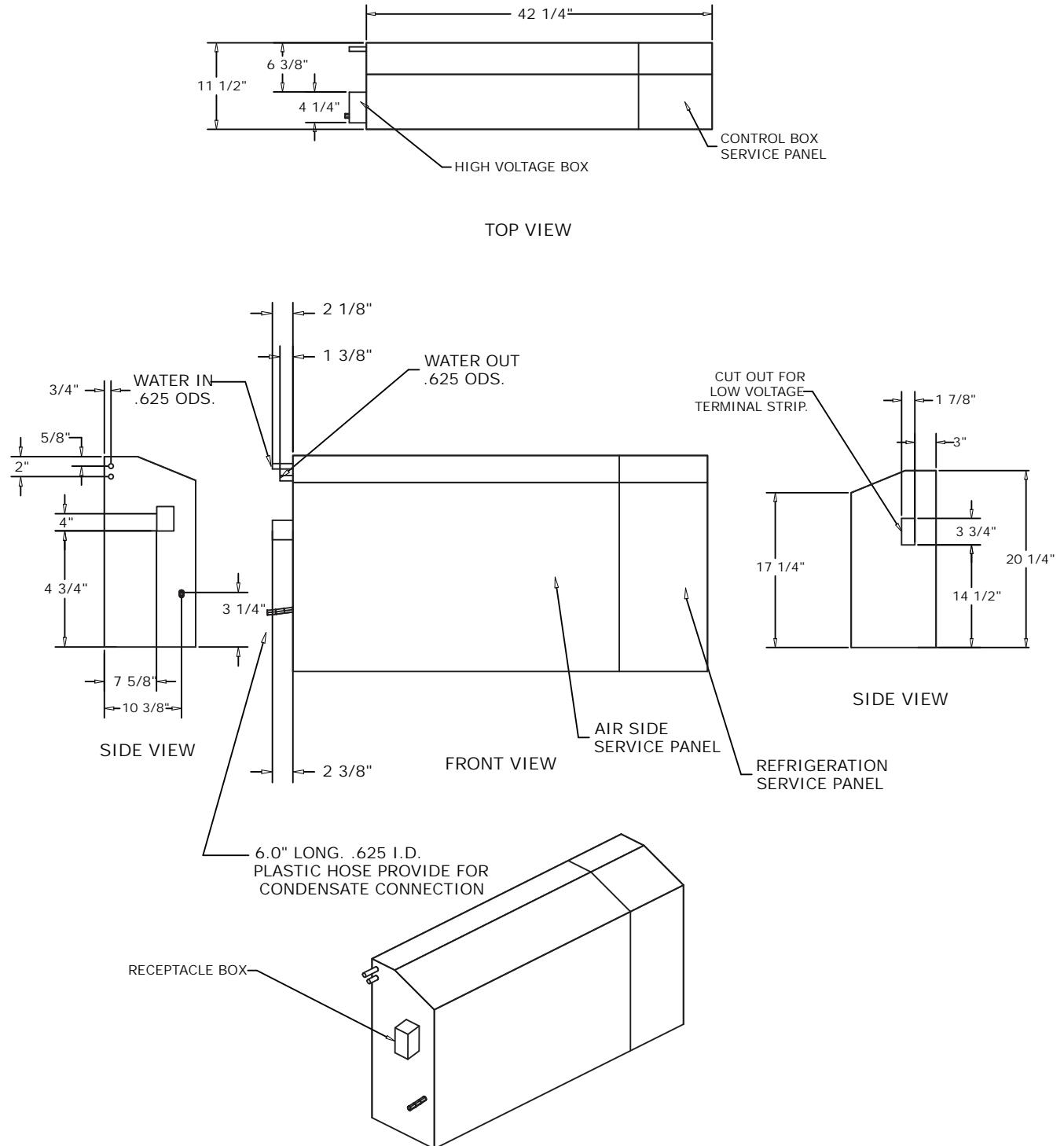

Figure 36. GEC 0.5 to 1.5 tons (60 Hz), 0.5 to 1.25 tons (50 Hz) - chassis (LH)







# Controls

## Deluxe 24V Controls

### Stand-alone System

The deluxe 24V design may be applied as a stand-alone control system. The stand-alone design provides accurate temperature control directly through a wall-mounted electronic thermostat.

This system set-up may be utilized in a replacement design where a single unit retrofit is needed.

It may be easily interfaced with a field provided control system by way of the factory installed 18-pole terminal strip. This stand-alone control is frequently utilized on small jobs where a building controller may not be necessary, or where field installed direct digital controls are specified. This type of control design does require a constant flow of water to the water source heat pump.

With a positive way to sense flow to the unit, the units safety devices will trigger the unit off. The stand-alone system design provides a low cost option of installation while still allowing room control for each unit.

**Figure 37. Deluxe 24V control board**

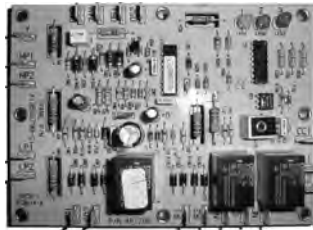

The deluxe 24 V design is a microprocessor-based control board conveniently located in the control box. The board is unique to Trane water-source products and is designed to control the unit as well as provide outputs for unit status and fault detection.

The board is factory wired to a terminal strip to provide all necessary terminals for field connections.

### Deluxe 24V electronic controls include:

- 18 pole strip for low voltage field wiring
- 75 VA transformer
- Anti-short cycle compressor protection
- Brown out protection
- Compressor contactor
- Compressor delay on start
- Compressor disable input
- Compressor lock-out relay
- Compressor run capacitor (for 1-phase units only)
- Condensate overflow
- Electric heat and compressor enable
- Freeze protection
- General alarm (dry contact closure when fault detected)
- High pressure switch
- Hot gas reheat
- LED diagnostics
- Low pressure switch
- Low pressure time delay
- Motorized 2-position damper

- Multi-speed fan motor
- Random start delay
- Reversing valve coil
- Soft lockout mode
- Two-speed fan motor

## **Deluxe 24V features**

### **Anti-short Cycle Timer**

The anti-short cycle timer provides a three minute time delay between compressor stop and compressor restart.

### **Brown-out Protection**

The brown-out protection function measures the input voltage to the controller and halts the compressor operation. Once a brown-out situation has occurred, the anti-short cycle timer will become energized. The general fault contact will not be affected by this condition. The voltage will continue to be monitored until the voltage increases. The compressors will be enabled at this time if all start-up time delays have expired, and all safeties have been satisfied.

### **Compressor Disable**

The compressor disable relay provides a temporary disable in compressor operation. The signal would be provided from a water loop controller in the system. It would disable the compressor because of low water flow, peak limiting or if the unit goes into an unoccupied state. Once the compressor has been disabled, the anti-short cycle time period will begin. Once the compressor disable signal is no longer present, and all safeties are satisfied, the control will allow the compressor to restart.

### **Diagnostics**

Three LEDs (light emitting diodes) are provided for indicating the operating mode of the controller. See the unit IOM for diagnostics or troubleshooting through the use of the LEDs.

### **Generic Relay**

The generic relay is provided for field use. Night setback or pump restart are two options that may be wired to the available relay.

A 24 Vac signal will energize the relay coil on terminals R1 and R2. Terminals C (common), NO (normally open), and NC (normally closed) will be provided for the relay contacts.

### **Random Start**

The random start relay provides a time delay start-up of the compressor when cycling in the occupied mode. A new start delay time between 3 and 10 seconds is applied each time power is enabled to the unit.

### **Safety Control**

The deluxe controller receives separate input signals from the refrigerant high pressure switch, low suction pressure switch, and condensate overflow.

In a high pressure situation, the compressor contactor is de-energized, which suspends compressor operation. The control will go into soft lockout mode initializing a three minute time delay and a random start of 3 to 10 second time delays. Once these delays have expired, the unit will be allowed to run. If a high pressure situation occurs within one hour of the first situation, the control will be placed into a manual lockout mode, halting compressor operation, and initiating the general alarm.

In a low temperature situation, the low pressure switch will transition open after the compressor starts. If the switch is open for 45 seconds during compressor start, the unit will go into soft lockout mode initializing a three minute time delay and a random start of 3 to 10 second time delays. Once these delays have expired, the unit will be allowed to run. If the low pressure situation occurs again within 30 minutes, and

the device is open for more than 45 seconds, the control will be placed into a manual lockout mode, halting compressor operation, and initiating the general alarm.

In a condensate overflow situation, the control will go into manual lockout mode, halting compressor operation, and initiating the general alarm.

The general alarm is initiated when the control goes into a manual lockout mode for either high pressure, low pressure or condensate overflow conditions.

### **Building Control Advantages**

The Symbio™ 400-B/Tracer® UC400-B controllers have the ability to share information with one or several units on the same communication link.

An advantage of installing a Symbio 400-B/UC400-B is its capability to work with other BACnet® controllers. This provides greater flexibility to the building owner, as well as greater flexibility in design.

Integrating the Symbio 400-B/UC400-B on water-source equipment, and tying it to a Tracer SC or other BAS system provides a complete building management system. With a Building Automation system like a Tracer SC, the system can initiate an alarm on a loss of performance on equipment malfunctions; allowing problems to be handled in a timely manner before compromising comfort.

This type of application would most commonly be used for a large space(s) that may require more than one unit. In addition to this application design, Symbio 400-B/UC400-B controller provides a way for units located within the same space to share the same zone sensor to prevent units from simultaneously heating and cooling in the same space.

***Note:** The sharing of information is made possible with a twisted pair of wire and a building automation system or through Tracer TU service tool.*

## **Symbio™ 400-B/Tracer® UC400-B**

The Symbio 400-B/UC400-B is a multi-purpose, programmable (or application-specific) that provides direct-digital zone temperature control. This controller can operate as a stand-alone device or as part of a building automation system (BAS). Communication between the controller and a BAS occurs on an open standard with inter-operable protocols used in Building Automation and Control Networks (BACnet). Programming is done by means of the Tracer TU service tool.

***Note:** For more information, please reference BAS-SVX065\*-EN or BAS-SVX092\*-EN.*

## **Symbio 400-B/Tracer® UC400-B functions include:**

### **Boilerless Control Electric Heat and Supplemental Electric Heat**

The controller supports a single stage of boilerless electric heat operation.

Electric heat is used when boilerless heat is enabled/configured and the EWT is too low for compressor operation. When this condition is met, the isolation valve will be closed shutting down the water flow to the unit.

When the unit is configured for boilerless control, the EWT will be used to determine whether DX heating should be disabled and the electric heater enabled. When these conditions are met, the isolation valve(s) are driven open for three minutes and the entering water temperature reading is taken. The determination as to whether or not to utilize electric heat will be made and the controller will take appropriate action. If boilerless electric heat is enabled, then the isolation valve will be closed, shutting down the water flow to the unit.

### **Compressor Operation**

The compressor is cycled on and off to meet heating or cooling zone demands. Units use the unit capacity and pulse width modulation (PWM) logic along with minimum on/off timers to determine the compressor's operation. The compressor is controlled ON for longer periods as capacity increases and shorter periods as capacity decreases.

## Condensate Overflow

When condensate reaches the trip point, a condensate overflow signal generates a diagnostic which disables the fan, unit water valves (if present), and compressor. The unit will remain in a halted state until the condensation returns to a normal level. At this time, the switch in the drain pan will automatically reset. However, the controller's condensate overflow diagnostic must be manually reset to clear the diagnostic and restart the unit.

## Data Sharing

The Symbio 400-B/UC400-B controller are capable of sending or receiving data (setpoints, fan request, or space temperature) to and from other controllers on the communication link. This allows multiple units to share a common space temperature sensor in both stand-alone and building automation applications.

## Dehumidification

Dehumidification for the water-source heat pump is applicable with the Symbio 400-B/UC400-B. The controller is capable of directing one stage of DX cooling in conjunction with one stage of reheat (hot gas reheat).

Dehumidification can only occur when the controller is in the cooling mode. A humidity sensor is used to measure the zone's relative humidity (RH), then compares the zone relative humidity to the relative humidity enable/disable setpoint parameters. The dehumidification enable and disable points are configurable.

**Note:** Standard electrical connections are in a 2 in. x 4 in. electrical box mounted on the chassis. An optional toggle switch is available on the standard 2 in. x 4 in. electrical box. Other electrical connection options are as follow:

## Receptacle Box

A factory shipped disconnect option receptacle option is available with the console configuration. With this option, the high voltage power is field wired directly through the disconnect receptacle. This safety feature provides ease of powering OFF the individual circuitry of a unit without interrupting electrical service to other equipment in a service or maintenance situation.

Trane offers two disconnection electrical connection options. Option A is non-fused. It consists of a power cord and its receptacle box. The receptacle box contains a 115 to 240V or 265V receptacle. It is factory shipped in the unit, and field installed at the jobsite. Option A is available in an extended cabinet length option.

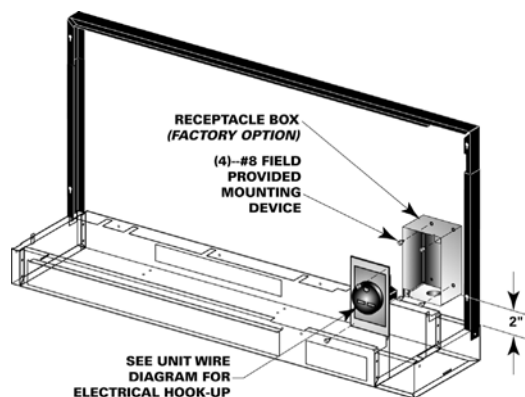

## Receptacle Box with Circuit Breaker

Option B disconnect includes a power cord/receptacle box with a circuit breaker. With this option, the circuit breaker may be reset directly at the unit during a power interruption situation.

The power cord/receptacle box with circuit breaker is available in 115 to 240V or 265V options. It is factory shipped in the unit, and field installed at the jobsite.

Option B disconnect is possible with both the standard length cabinet configuration and the extended length cabinet option.

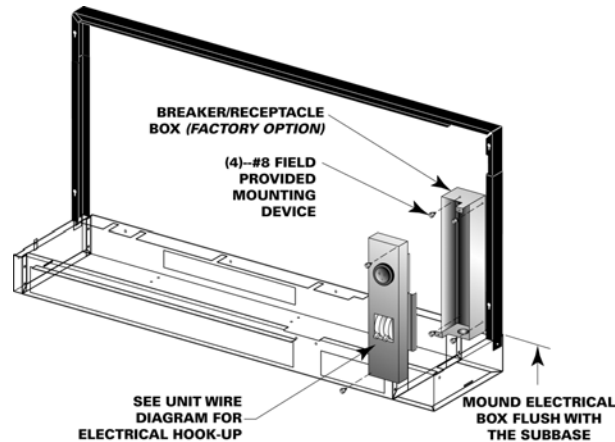

### Fan Operation

The supply air fan operates at the factory wired speed in the occupied or occupied standby mode. When switch is set to AUTO, the fan is configured for cycling ON with heating or cooling. In heat mode, the fan will run for 30 seconds beyond compressor shutdown in both occupied and unoccupied mode.

### Filter Maintenance Timer

The controller filter status is based on the unit fan's cumulative run hours. The controller compares the fan run time against an adjustable fan run hours limit and recommends unit maintenance as required.

### High and Low Pressure Switches

The Symbio 400-B/UC400-B detects the state of the high pressure or low pressure switches. When a fault is sensed by one of these switches, the corresponding message is sent to the controller to be logged into the fault log. When the circuit returns to normal, the high pressure control and low pressure control automatically reset. If a second fault is detected within a thirty-minute time span, the unit must be manually reset.

### Occupancy Modes

The four operations of the Symbio 400-B/UC400-B controller include occupied, occupied standby, occupied bypass and unoccupied.

In an occupied situation, the controller uses occupied heating and cooling setpoints to provide heating and cooling to the building. This occupied operation is normally used during the daytime hours when the building is at the highest occupancy level.

In an occupied standby situation, the controllers heating and cooling setpoints are usually wider than the occupied setpoints. This occupied standby operation is used during daytime hours when people are not present in the space (such as lunchtime or recess). To determine the space occupancy, an occupancy sensor is applied.

In an unoccupied situation, the controller assumes the building is vacant, which normally falls in evening hours when a space may be empty. In the unoccupied mode, the controller uses the default unoccupied heating and cooling setpoints stored in the controller. When the building is in unoccupied mode, individual units may be manually placed into timed override of the unoccupied mode at the units wall sensor. During timed override, the controller interprets the request and initiates the occupied setpoint operation, then reports the effective occupancy mode as occupied bypass.

In the occupied bypass mode, the controller applies the occupied heating and cooling setpoint for a 120 minute time limit.



### **Random Start**

To prevent all of the units in a building from energizing major loads at the same time, the controller observes a random start from 0 to 25 seconds. This timer halts the controller until the random start time expires.

### **Reversing Valve Operation**

For cooling, the reversing valve output is energized simultaneously with the compressor. It will remain energized until the controller turns on the compressor for heating. At this time, the reversing valve moves to a de-energized state. In the event of a power failure or controller OFF situation, the reversing valve output will default to the heating (de-energized) state.

### **Additional Functions of the Symbio 400-B/UC400-B Controller**

When the building owners choice is Trane Tracer controls, the Symbio 400-B/UC400-B controller is required when any of the following applications are selected.

- Hot Gas Reheat (for Dehumidification)
- Boilerless Control for Electric Heat
- Water Isolation Valve Control (for Variable Speed Pumping)

### **Entering Water Temperature Sampling**

The controller will sample the entering water temperature to determine proper control action for units equipped with boilerless electric heat or waterside economizer.

### **Water Isolation Valve**

Variable speed pumping systems are supported by the controller when water isolation valves are present. up to two isolation valves are supported by the Symbio 400-B/UC400-B controller (one for each compressor circuit). The valves are normally closed unless DX heating, DX cooling, waterside economizer or dehumidification is requested. When the isolation valves are driven open for operation, the outputs will be driven for 20 seconds to ensure adequate water flow before the compressor outputs are energized. Once an isolation valve has been opened, it will remain open for a 10 minute minimum to reduce excessive cycling of the valve.

## **Trane® Air-Fi® Wireless Systems**



Trane Air-Fi wireless systems provides significant advantages to better meet customer by providing a lower initial cost; ease of installation for reduced risk; increased reliability and flexibility for easier problem solving; and fewer maintenance issues for worry-free operation and cost savings over the life of the system. Trane Air-Fi wireless systems helps save time and money, with industry-leading technology and performance.

### **Air-Fi Wireless Communications Interface (WCI)**

The Air-Fi Wireless Communications Interface (WCI) enables wireless communications between system controls, unit controls, and wireless sensors for Trane control products that use the BACnet protocol. The WCI replaces the need for communications wire in all system applications.

The WCI is available in three configurations:

- The universal model is the most common. It installs the same as a wired zone sensor in indoor applications.
- The outdoor model is housed in an enclosure suitable for outdoor environments. It is usually used on equipment above the roof deck.

- The flush mount model is used on fan coils, blower coils, and unit ventilators.

### **Air-Fi Wireless Communications Sensor (WCS)**

The Air-Fi Wireless Communications Sensor (WCS) is compatible with any Trane controller that uses a WCI. The WCS provides the same functions as many currently available Trane wired sensors. No further software or hardware is necessary for site evaluation, installation, or maintenance. Space temperature is standard on all models. (A service tool cannot be connected to a Trane wireless sensor.)

Three WCS models are available:

- Digital display (WCS-SD) model.
- Base (WCS-SB) model has no exposed display or user interface.
- 2% relative humidity sensor module (WCS-SH), which can be field installed inside either the WCS-SD or WCS-SB.

In most applications, one WCS-SD or WCS-SB sensor will be used per WCI acting as a router. However, up to 6 WCS-SD or WCS-SB sensors can be associated to a single equipment controller or BCI.

### **Compatibility with Previous Generation Wireless Zone Products**

Our previous line of wireless zone sensors (WZS, WTS, and WDS) are not compatible with the Air-Fi Wireless Communications Interface (WCI).





The new Air-Fi Wireless Communications Sensor (WCS) are compatible with old WCIs that have updated firmware.

### **Wired Zone Sensors**

Wired zone sensors can be used with Air-Fi wireless systems.





# Thermostats and Zone Sensors

**Table 29. Thermostat selection for use with the deluxe 24V controller**

Thermostat	Part Number	Description
	X13511535010	1 Heat/1 Cool, non-programmable commercial thermostat for conventional air conditioners and heat pumps that are configured without auxiliary heat <ul style="list-style-type: none"> <li>• 1 H/1 C</li> </ul>
	X13511536010	3 Heat/2 Cool, non-programmable commercial thermostat for conventional air conditioners and heat pumps that are configured with or without auxiliary heat. <ul style="list-style-type: none"> <li>• 3 H/2 C</li> </ul>
	X13511537010	3 Heat/2 Cool, programmable commercial thermostat for conventional (rooftop) air conditioners and heat pumps that are configured with or without auxiliary heat. <ul style="list-style-type: none"> <li>• 3 H/2 C</li> </ul>
	X13511538010	3Heat/2 Cool, programmable touch screen thermostat for conventional air conditioners and heat pump systems. The thermostat will provide the human interface, zone temperature sensing both local and optional remote temperature sensing, and set point scheduling on a daily/weekly basis. This thermostat can also display humidity with a control signal for dehumidification with a local humidity sensor or optional remote humidity sensor. <ul style="list-style-type: none"> <li>• 3 H/2 C</li> </ul>



## Thermostats and Zone Sensors

**Table 30. Zone sensor selection for use with Symbio™ 400-B/Tracer® UC400-B controller**



Sensor	Part Number	Description
	X13790886010	Wired temperature sensor with an LCD display <ul style="list-style-type: none"> <li>Allows an occupant to control the temperature setpoint, request timed override of system operation, and provides a COMM module to service technicians. Symbio 400-B/UC400-B Compatible.</li> </ul>
	X13651467020	Communication Module <ul style="list-style-type: none"> <li>Sold in packs of 12.</li> <li>Provides local RJ22 connection to Trane® service tools for easy, low cost maintenance.</li> </ul>
	X13511529010	Zone Sensor <ul style="list-style-type: none"> <li>Symbio 400-B/UC400-B compatible.</li> <li>External setpoint adjustment wheel.</li> </ul>
	X13511527010	Zone Sensor <ul style="list-style-type: none"> <li>Symbio 400-B/UC400-B compatible.</li> <li>External setpoint adjustment wheel.</li> <li>ON and CANCEL buttons.</li> </ul>
	X1379084501	Zone Sensor <ul style="list-style-type: none"> <li>Symbio 400-B/UC400-B compatible.</li> <li>External setpoint adjustment wheel.</li> <li>ON and CANCEL buttons.</li> <li>Fan switch AUTO-OFF.</li> </ul>
	X1379044401	<ul style="list-style-type: none"> <li>Temperature and relative humidity sensor</li> <li>Symbio 400-B/UC400-B compatible.</li> </ul>

## Thermostats and Zone Sensors

**Table 30. Zone sensor selection for use with Symbio™ 400-B/Tracer® UC400-B controller (continued)**

Sensor	Part Number	Description
	X13790993001	<p>Commercial Touch Screen Programmable Zone Sensor</p> <ul style="list-style-type: none"> <li>• Supports Standby, Occupied, and Unoccupied.</li> <li>• 7 day, 5+2 day, and 5+1+1 day.</li> <li>• Cannot be used with BAS as sensor ties up BACnet link. For use with factory programmed Symbio 400-B/UC400-B.</li> </ul> <p><b>Notes:</b></p> <ul style="list-style-type: none"> <li>• <i>Adjusting the rotary switch on Symbio 400-B/UC400-B may be required to correspond address configuration in the sensor. See the installation manual for more information.</i></li> <li>• <i>Additional configuration is needed in the field to use the Programmable zone sensors (to put BAS points in service on Symbio 400-B/UC400-B).</i></li> </ul>
	X13790992001	<p>Residential Touch Screen Programmable Zone Sensor</p> <ul style="list-style-type: none"> <li>• Supports Awake, Away, Home, and Sleep.</li> <li>• 7 day, 5+2 day, and 5+1+1 day.</li> <li>• Cannot be used with BAS as sensor ties up BACnet link. For use with factory programmed Symbio 400-B/UC400-B.</li> </ul> <p><b>Notes:</b></p> <ul style="list-style-type: none"> <li>• <i>Adjusting the rotary switch on Symbio 400-B/UC400-B may be required to correspond address configuration in the sensor. See the installation manual for more information.</i></li> <li>• <i>Additional configuration is needed in the field to use the Programmable zone sensors (to put BAS points in service on Symbio 400-B/UC400-B).</i></li> </ul>

**Table 31. Wireless zone sensor selection for use with Symbio 400-B/UC400-B controller**

Sensor	Part Number	Description
	X13790955050	<p>Trane Air-Fi WCS-SD (display)</p> <ul style="list-style-type: none"> <li>• Symbio 400-B/UC400-B Compatible.</li> <li>• Easy-to-use interface for clear and simple monitoring and control.</li> </ul>
	X13790956010	<p>Trane Air-Fi WCS-SB (base)</p> <ul style="list-style-type: none"> <li>• Symbio 400-B/UC400-B Compatible.</li> <li>• Simplicity.</li> <li>• Eliminates local temperature control when higher control level is required.</li> </ul>





# Mechanical Specifications

## General

Equipment shall be completely assembled, piped, internally wired and test operated at the factory. It shall be both ETL and ISO-AHRI 13256-1 listed and labeled prior to leaving the factory. Service and caution area labels shall also be placed on the unit in their appropriate locations.

## Air-to-Refrigerant Coil

Internally finned, 3/8-inch copper tubes mechanically bonded to a configured aluminum plate fin as standard. Coils are leak tested at the factory to ensure the pressure integrity. The coil shall be leak tested to 450 psig and pressure tested to 650 psig. The tubes are to be completely evacuated of air and correctly charged with proper volume of refrigerant prior to shipment.

The refrigerant coil distributor assembly shall be of orifice style with round copper distributor tubes. The tubes are sized consistently with the capacity of the coil. Suction header is fabricated from rounded copper pipe.

A thermostatic expansion valve is factory selected and installed for a wide range of control.

## Ball Valves

Ball valves are field installed between the unit and the supply and return lines of the loop to stop water flow to the unit in a maintenance or service situation.

## Cabinet

The cabinet shall be constructed of sturdy galvanized steel, with exposed edges rounded. The steel shall include electrostatic powder paint in three attractive colors for an appliance grade finish. Service to the refrigerant and controls shall be provided through a single access panel at the front of the unit chassis. Insulation for the internal parts and surfaces exposed to the conditioned air stream shall be made of moisture resistant insulation.

The insulation shall be ½-inch thick dual density bonded glass fiber. The exposed side shall be a high density erosion proof material suitable for use in airstreams up to 4500 feet per minute (FPM). Insulation shall meet the Underwriters' Laboratories Fire Hazard Classification:

- Flame spread = 25
- Smoke developed = 50

Access for inspection and cleaning of the unit drain pan, coils and fan section shall be provided. The unit shall be installed for proper access. Procedures for proper access inspection and cleaning of the unit shall be included in the maintenance manual.

## Drain Pan

The drain pan shall be constructed of corrosion resistant material and insulated to prevent sweating. The bottom of the drain pan shall be sloped on two planes which pitches the condensate to the drain connection.

## Electric Heat (option)

The boilerless electric heat option shall be factory wired and tested. It shall be composed of a nichrome open wire coil designed for 2-kW per unit ton. It shall consist of a single stage of electric heat used as a primary heating source when compressor lockout has occurred due to the entering water temperature falling below 55°F in a boilerless situation.

## Electrical

The factory tested and installed control box shall contain all necessary devices to allow heating and cooling operation of the equipment to occur from a remote wall thermostat or zone sensor. These devices shall be as follows:

- 24 Vac Energy Limiting Class II, 50VA breaker with external fuse or 75VA with a circuit breaker.
- 24 Vac contactor for compressor control.

- 18 pole terminal strip located inside the control box behind the service access panel. This terminal strip shall be used for low voltage (thermostat/zone sensor) connections.
- An electrically operated safety lockout relay shall help prevent cycling of the compressor during adverse conditions of operation. This device shall be reset either at the remote thermostat/zone sensor, or by cycling power to the unit.
- A high pressure switch shall help protect the compressor against operation at refrigerant system pressure in excess of 650 psig.
- A low pressure switch shall help prevent compressor operation under low charge or catastrophic loss of charge situations.
- Factory installed wire harness shall be available for the Deluxe, Symbio™ 400-B/Tracer® UC400-B and Terminal Unit Control packages.

### Fans

The fans shall be placed in a blow-through configuration. They shall be constructed of corrosion resistant galvanized material.

### Filters

One inch throwaway filters shall be standard and factory installed. The filters shall have an average resistance of 76-percent and dust holding capacity of 26-grams per square foot.

### Hoses (option)

Hoses shall consist of a stainless steel outer braid with an inner core of tube made of a nontoxic synthetic polymer material. The hoses shall be suitable for water temperatures ranging between 33°F and 211°F without the use of glycol.

### Automatic Flow Devices (option)

The automatic self-balancing device shall automatically limit the rate of flow to within 10-percent of the specified amount, over a 40 to 1 differential pressure operating range of 2 to 80 PSID. The operational temperature shall be rated from fluid freezing, to 225°F.

The valve body shall be suited for working pressures of 400 PSIG. The valve internal core shall consist of one or more high temperature elastomeric diaphragms and precision orifice with sculptured orifice seat.

Dual pressure/temperature test ports shall be standard for verifying the pressure differential and system temperature.

### Motors

The motors shall be a multi-speed permanent split capacitor with thermal overload protection. A high and low switching device shall be provided for all units and accessible behind the hinged control door. The motor shall contain a quick-disconnect plug and permanently lubricated bearing.

### Pump Module (field installed accessory)

The pump module shall consist of either a single or dual 1/6 HP cast iron pump and a brass 3-way shut-off valve. The pump module kits shall contain the necessary components for the installation, operation and maintenance of the water circuit of a closed-loop distributed pumping application.

### Reheat Coil (option)

Dehumidification shall be provided through a hot gas reheat option. The coil shall consist of copper tubes mechanically expanded into evenly spaced aluminum fins. All coils are to be proof and leak tested. The proof must be performed at 1.5 times the maximum operating pressure and the leak test at the maximum operating pressure. In addition, the tubes are to be completely evacuated of air to check for leaks in a vacuum.

## Mechanical Specifications

---

### Refrigerant Metering

The equipment shall be provided with a (TXV) thermal expansion valve to allow operation of the unit with entering fluid temperature from 25°F to 120°F.

### Refrigeration System Compressor

The unit shall include a general efficiency rotary compressor. External vibration isolation shall be provided by rubber mounting devices located underneath the mounting base of the compressor. A second isolation of the refrigeration assembly shall be supported under the compressor mounting base.

Thermal overload protection shall be provided. Protection shall be provided against excessive discharge pressure operation by means of a high pressure switch. Loss of charge protection shall be provided by a low pressure switch.

### Refrigerant Tubing

The refrigerant tubing shall be of 99% pure copper. This system shall be free from contaminants and conditions such as drilling fragments, dirt and oil. All refrigerant and water lines shall be insulated with an elastomeric insulation that has a 3/8-inch thick wall where ever air is introduced to the assembly.

### Sound Attenuation

Sound attenuation shall be applied as a standard feature in the product design.

The sound reduction package shall include a vibration isolation to the compressor and water-to-refrigerant coil, a second stage of vibration isolation to the compressor base pan, heavy gauge base assembly, insulated metal compressor enclosure, and maximum sized return-air opening and filter sizing.

The unit shall be tested and rated in accordance with AHRI 350.

### Water-to-Refrigerant Heat Exchanger

The water-to-refrigerant heat exchanger shall be of a high quality co-axial coil for maximum heat transfer. The copper or optional cupro-nickel coil shall be deeply fluted to enhance heat transfer and minimize fouling and scaling. The coil has a working pressure of 400 psig on the water side and 650 psig on the refrigerant side. The factory shall provide rubber isolation to the heat exchanging device to enhance sound attenuation.





The AHRI Certified mark indicates Trane U.S. Inc. participation in the AHRI Certification program. For verification of individual certified products, go to [ahridirectory.org](http://ahridirectory.org).

Trane - by Trane Technologies (NYSE: TT), a global climate innovator - creates comfortable, energy efficient indoor environments for commercial and residential applications. For more information, please visit [trane.com](http://trane.com) or [tranetechnologies.com](http://tranetechnologies.com).

Trane has a policy of continuous product and product data improvement and reserves the right to change design and specifications without notice. We are committed to using environmentally conscious print practices.





## 1.2 - Library Heat Recovery Chiller

Job Name **Sample - Would need 2 not 7**  
 Location **modules**  
 Engineer  
 Contractor

Job Number \_\_\_\_\_  
 Quote Number QJRYAN06062022-2  
 Representative Jared Ryan  
 Rep Office Albany

**Mechanical Modules:** (7) ARA030LNHC3ABAA2I--DG-G-A-WCA---A  
**Accessory Modules:**

Based on (7) ARA030LNHC3ABAA2I--DG-G-A-WCA---A operating

COOLING PERFORMANCE DATA											
Load	Cooling (tons)	Input kW	kW/Ton	EER	COP	Fan kW	Flow Rate (GPM)	Entering Temp. °F	Leaving Temp. °F	ΔP (ft H2O)	Ambient °F
100%	186.1	214.5	1.152	10.42	3.050	18.20	468.9	54.00	44.00	10.45	95.00

Based on (7) ARA030LNHC3ABAA2I--DG-G-A-WCA---A operating

SIMULTANEOUS PERFORMANCE DATA											
Load	Cooling (tons)	Input kW	Heating (MBH)	kW/Ton	Heating & Cooling COP	Flow Rate (GPM)	Leaving Temp. °F	ΔP (ft H2O)	Cond Flow (GPM)	Leaving Temp. °F	ΔP (ft H2O)
100%	141.4	267.1	2609	1.888	4.720	356.5	44.00	10.45	534.3	140.0	11.16

Based on (7) ARA030LNHC3ABAA2I--DG-G-A-WCA---A operating

HEATING PERFORMANCE DATA									
Load	Heating (MBH)	Input kW	Heating COP	Fan kW	Cond Flow (GPM)	Entering Temp. °F	Leaving Temp. °F	ΔP (ft H2O)	Ambient °F
100%	1328	251.3	1.550	18.20	278.6	130.0	140.0	11.16	0.0000

COOLING DESIGN DATA-LOAD SIDE (Based on 30% PG)	
Entering Temperature °F	54.00
Leaving Temperature °F	44.00
Design Flow (GPM)	468.9
Pressure Drop (Full Load)	4.524 PSI / 10.45 ft H2O
Chiller Minimum Flow (GPM)	468.9
Min. GPM For Sizing System Bypass	468.9

COOLING MODE AMBIENT DESIGN DATA Based On Sea Level Elevation	
Ambient Temperature °F	95.00
Minimum Ambient °F	20.00
Coil Type	Al/Cu Condenser Coils-None

SIMULTANEOUS COOLING DESIGN DATA (Based on 30% PG)	
Entering Temperature °F	54.00
Leaving Temperature °F	44.00
Design Flow (GPM)	356.5
Pressure Drop (Full Load)	4.524 PSI / 10.45 ft H2O
Chiller Minimum Flow (GPM)	356.5

SIMULTANEOUS HEATING DESIGN DATA (Based on 30% PG)	
Entering Temperature °F	130.0
Leaving Temperature °F	140.0
Design Flow (GPM)	534.3
Pressure Drop (Full Load)	4.831 PSI / 11.16 ft H2O
Chiller Minimum Flow (GPM)	534.3

HEATING MODE AMBIENT DESIGN DATA	
Ambient Temperature °F	0.0000
Maximum Ambient °F	55.00
Coil Type	Al/Cu Condenser Coils-None

HEATING DESIGN DATA-LOAD SIDE (Based on 30% PG)	
Entering Temperature °F	130.0
Leaving Temperature °F	140.0
Design Flow (GPM)	278.6
Pressure Drop (Full Load)	4.831 PSI / 11.16 ft H2O
Chiller Minimum Flow (GPM)	278.6
Min. GPM For Sizing System Bypass	278.6

EVAPORATOR HEAT EXCHANGER DETAIL	
Heat Exchanger Style	Brazed Plate
Fouling Factor (h-ft <sup>2</sup> -°F/Btu)	.000100
Header Connection Size (in.)	6
Header Connection Type	Grooved Coupling
Max Water Side Working ΔP (PSI)	150 PSI

CONDENSER HEAT EXCHANGER DETAIL	
Heat Exchanger Style	Brazed Plate
Fouling Factor (h-ft <sup>2</sup> -°F/Btu)	.000100
Header Connection Size (in.)	6"
Header Connection Type	Grooved Coupling
Max Water Side Working ΔP (PSI)	150 PSI

PHYSICAL DATA	
Length (in.)	See Multistack for Details
Width (in.)	See Multistack for Details
Height (in.)	See Multistack for Details
Estimated Dry Weight (lbs.)	See Multistack for Details
Estimated Operating Weight (lbs.)	See Multistack for Details
Refrigerant Type	410A
Refrig. Charge (lbs/circuit)	See Multistack for Details

ELECTRICAL DATA	1	2	3	4
(7) ARA030L	7	0	0	0
MCA	*499			
MOP	600			
Voltage	460/60/3			

CHILLER DATA	
Compressor Descr	Scroll
Compressor RLA (per comp)	29.7
# of Compress. (per mod.)	2
Fan Qty (per module)	2
Fan FLA (A) (per fan)	5.4

MOUNTING/LIFTING FRAME	
Materials	Option Not Selected
Design	Option Not Selected
I-Beam Size	Option Not Selected
Width of Walkway/Passage	Option Not Selected
Bolt together frame - # of piece	Option Not Selected
End Type	Option Not Selected

Software Version #: 1.0.4435.26000

Performance Run Date: 6/6/2022 8:23:57 AM

\*Parallel feeds required.

Outside the scope of AHRI Air-Cooled Water-Chilling Packages Certification Program, but is rated in accordance with AHRI Standard 550/590 (I-P) and AHRI Standard 551/591 (SI).

Combined units or modular chiller array rating is outside of the scope of the AHRI Air-Cooled Water-Chilling Packages Certification Program. Individual unit ratings are subject to the governing documents of the AHRI Certification Program.

Unit contains freeze protection fluids in the evaporator with a leaving chilled fluid temperature above 32°F [0°C] and is certified when rated per the Standard with water.

## Part Load Performance

COOLING PERFORMANCE DATA										
Load	Capacity (tons)	Input kW	kW/Ton	EER	COP	Fan kW	Flow Rate (GPM)	Leaving Temp. °F	ΔP (ft H2O)	Ambient °F
100%	186.1	214.5	1.152	10.42	3.050	18.20	468.9	44.00	10.45	95.00
75%	139.6	125.4	0.8982	13.36	3.910	10.08	468.9	44.00	10.45	80.00
50%	93.07	63.88	0.6864	17.48	5.120	4.900	468.9	44.00	10.45	65.00
25%	46.53	30.80	0.6619	18.13	5.310	2.660	468.9	44.00	10.45	55.00

HEATING PERFORMANCE DATA									
Load	Heating (MBH)	Input kW	Heating COP	Fan kW	Cond Flow (GPM)	Leaving Temp. °F	ΔP (ft H2O)	Ambient °F	
100%	1328	251.3	1.550	18.20	278.6	140.0	11.16	0.0000	
75%	996.1	157.0	1.860	10.08	278.6	140.0	11.16	18.00	
50%	664.1	85.33	2.280	4.900	278.6	140.0	11.16	37.00	
25%	332.0	35.23	2.760	2.660	278.6	140.0	11.16	55.00	

## **Other Services & Special Features:**

- Chiller Waterside Maximum Working Pressure is 150 PSIG
- Filters in Evaporator and Condenser Supply Headers
- Stainless Steel Inlet Headers
- Stainless steel evaporator and condenser
- Lead compressor sequencing(24hrs)
- Automatic internal rescheduling if fault occurs
- Multiple, independent refrigeration systems
- Automatic logging of any fault condition
- Electronic chilled water control
- Quick interconnect modular design
- R-410A Refrigerant
- 5kA SCCR
- Electrical Connection Type - Junction Box
- Warranty: Compressor (5 Year)
- Warranty: All Parts (1 Year)
- 3/4" Closed Cell Foam Insulation
- Al/Cu Condenser Coils
- Single Point Power Connection
- Brazed Plate Evaporator
- 2 Condenser Fans per module
- External Master Controller Box
- ECM-1 Fans

## **Excluded By Multistack**

- Any Travel and Diagnosis for Warranties
- Multistack recommends a 2-3 minute minimum loop time. Contact Multistack if you have questions regarding system loop time design
- Door Interlock Disconnect Switch



*There is no job specific drawing available for this configuration. Please contact Multistack for a detailed drawing.*



<b>Job/Project:</b>	<b>Representative:</b> Wallace Eannace Associates		
<b>ESP-Systemwize:</b> WIZE-E7148C69	<b>Created On:</b> 06/23/2023	<b>Phone:</b> (516) 454-9300	
<b>Location/Tag:</b>	<b>Email:</b> info-ny@wea-inc.com		
<b>Engineer:</b>	<b>Submitted By:</b>	<b>Date:</b>	
<b>Contractor:</b>	<b>Approved By:</b>	<b>Date:</b>	

### Base Mounted End Suction Pump

**Series: e-1510**

**Model: 1.25AD-es**

#### Features & Design

- ANSI/OSHA Coupling Guard
- Center Drop Out Spacer Coupling
- Fabricated Heavy Duty Baseplate
- Internally Self-Flushing Mechanical Seal



\*The Bell & Gossett Series e-1510 is available in 26 sizes and a variety of configuration options that enable customization and flexibility to fit a broad range of operating conditions.

<http://bellgossett.com/pumps-circulators/end-suction-pumps/e-1510/>

### Pump Selection Summary

Duty Point Flow	48.5 US gpm
Duty Point Head	32 ft
Control Head	9.6 ft
Duty Point Pump Efficiency	63.3 %
Part Load Efficiency Value (PLEV)	60.7 %
Impeller Diameter	5.75 in
Motor Power	0.75 hp
Duty Point Power	0.618 bhp
Motor Speed	1800 rpm
RPM @ Duty Point	1744 rpm
NPSHr	3.65 ft
Minimum Shutoff Head	36.1 ft
Minimum Flow at RPM	7.15 US gpm
Flow @ BEP	47.7 US gpm
Fluid Temperature	55 °F
Fluid Type	Water
Weight (approx. - consult rep for exact)	130 lbs
Pump Floor Space Calculation	2.64 ft <sup>2</sup>

### Performance Curve

#### Energy Efficiency Ratings:

Pump & Motor PEIcI: 0.78 ERcI: 22  
Pump, Motor & Drive: PEIvI: 0.44 ERvI: 56



**e-1510**  
**1.25AD-es**  
**1744 RPM**

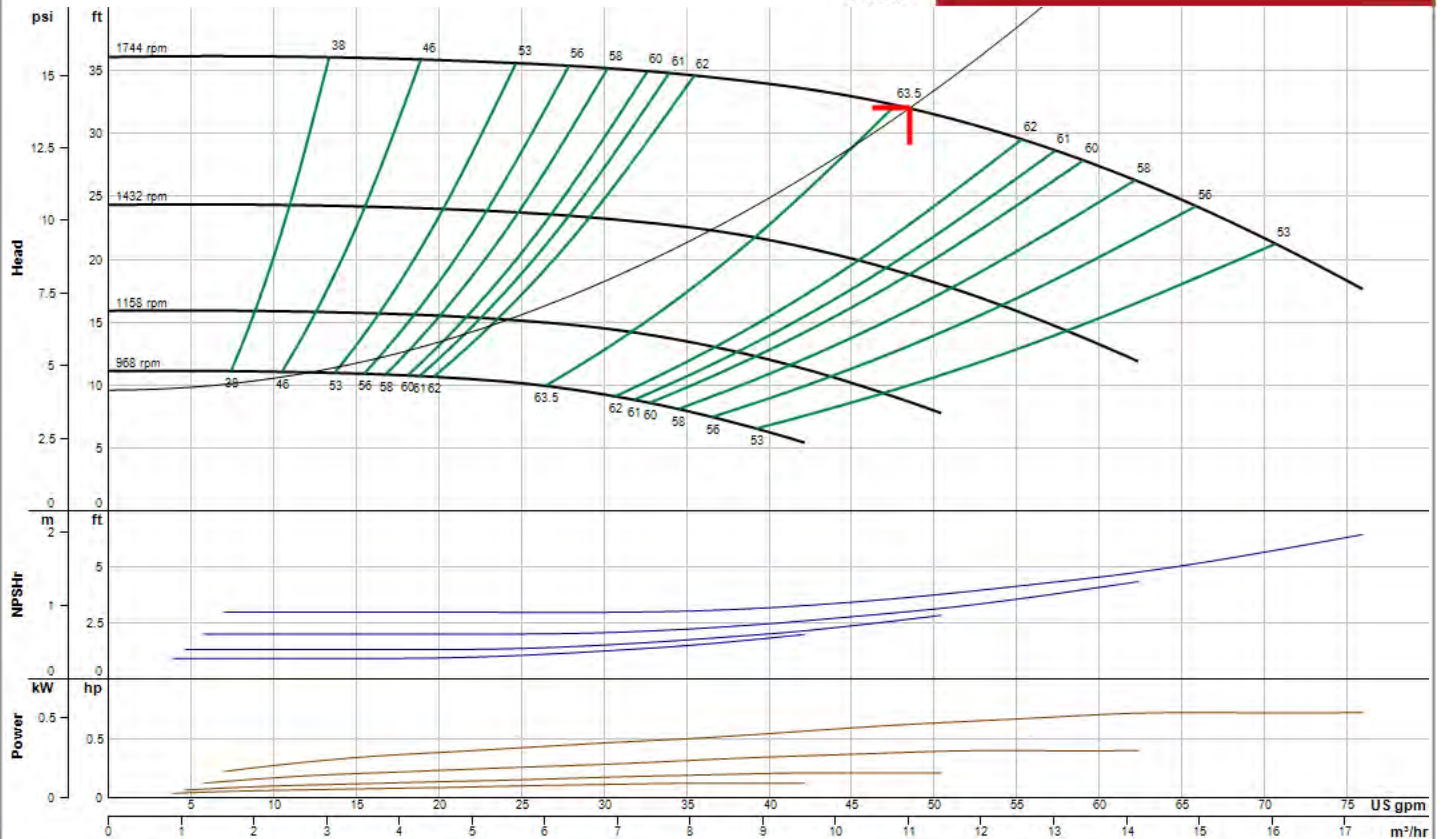

# Constant Speed Curve (1750 rpm)

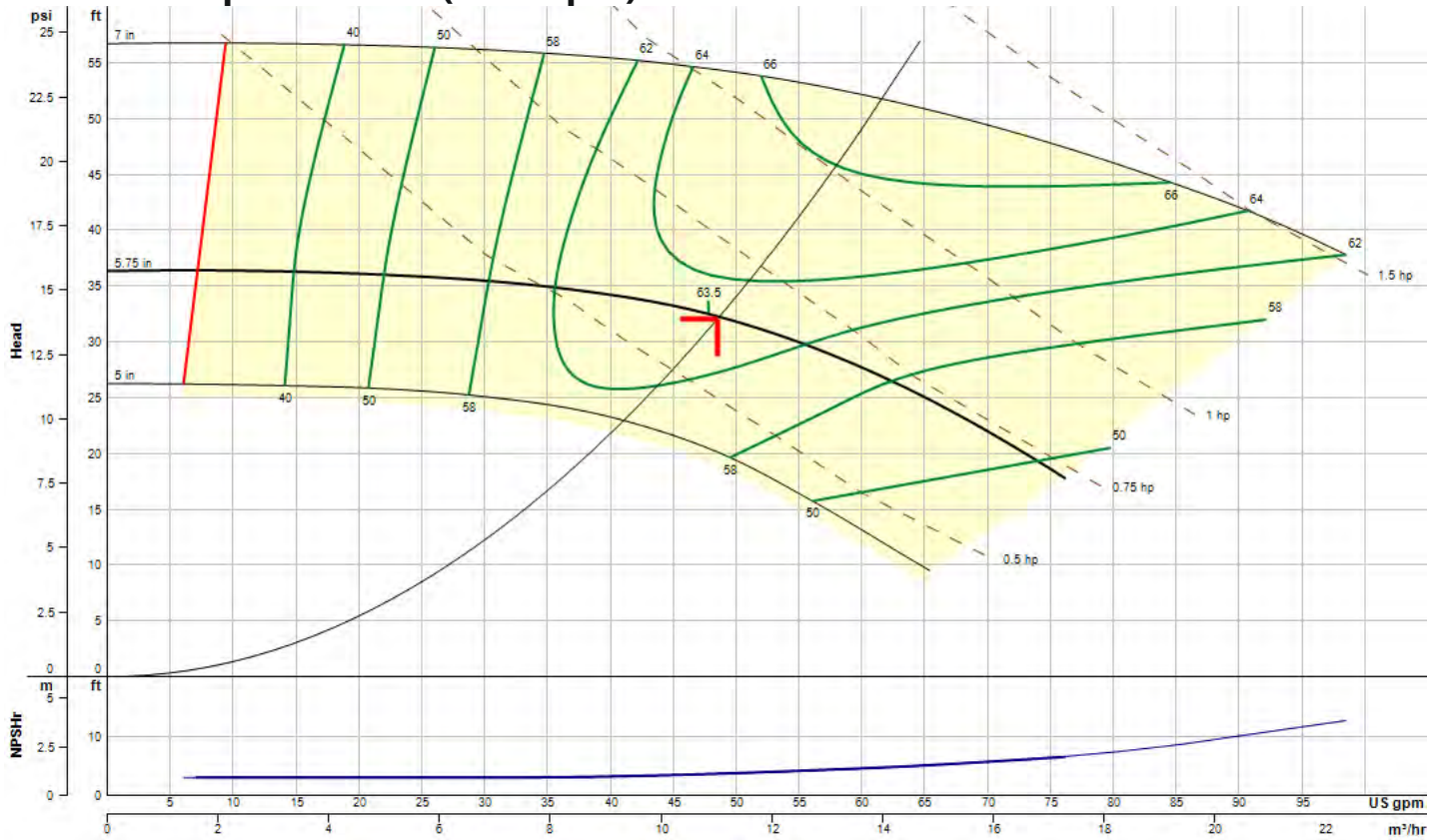

## Operating Point

**Flow:** 48.5 US gpm **Head:** 32 ft **Speed:** 1744 **Efficiency:** 63.3% **Point BHP:** 0.618 **End Of Curve:** 63.8%

## Maximum Duty Point (at rated motor speed)

**Flow:** 48.6 US gpm **Head:** 32.2 ft **Speed:** 1750 **Efficiency:** 63.3% **Point BHP:** 0.624 **NOL Flow:** 76.2 US gpm **Runout Flow:** 76.2 US gpm **NOL (BHP):** 0.727

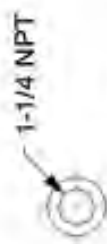

1-1/4 NPT DISCHARGE DETAILS

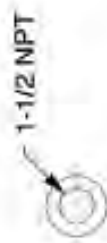

1-1/2 NPT SUCTION DETAILS

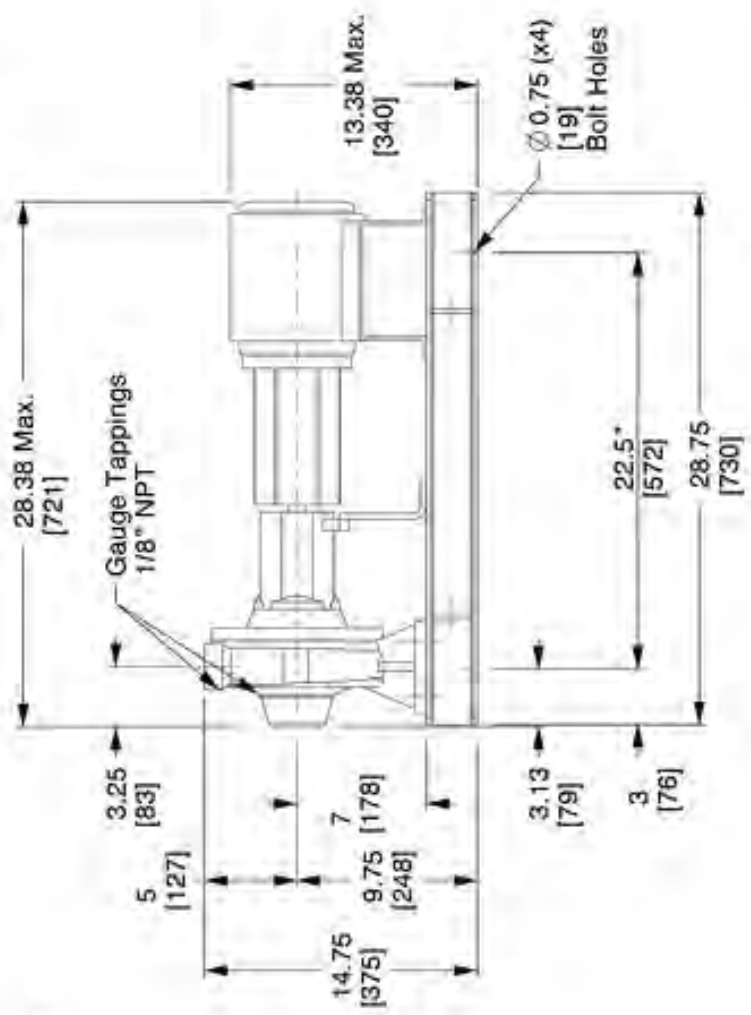
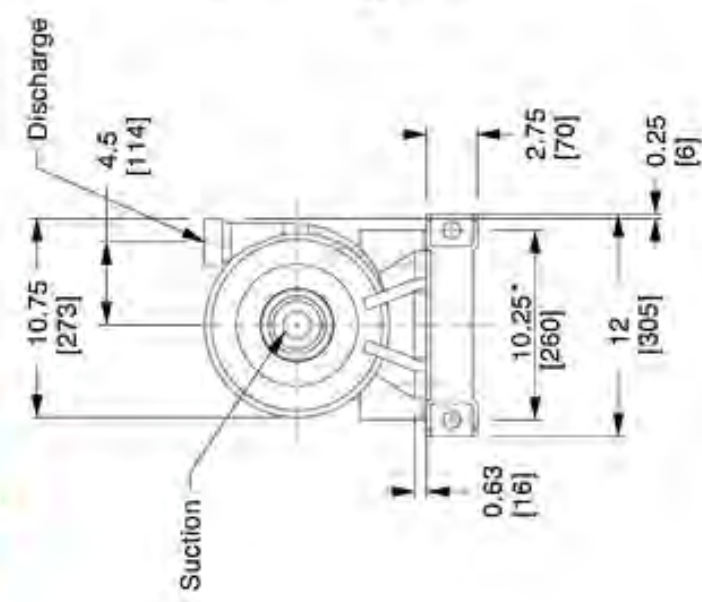

\* Dist. Between Bolt Holes



**Bell & Gossett**  
a xylem brand

8200 N. Austin Ave.  
Morton Grove, IL 60053, USA

This drawing and the information depicted therein is the property of Xylem. Copies are issued in strict confidence and shall not be reproduced or copied, or used as the basis for the manufacture or sale of products without prior written permission of Xylem.

Dimensions are subject to change  
Not to be used for construction unless certified

**BG-E1510-1P25ADES-SS-56**

Series e-1510 Centrifugal Pumps - Base Mounted  
Seal Type: Standard Seal | Motor Frame: 56 | Frame Type: ea

Dimensions : IN (mm)	Scale : N.T.S.	Submittal # : B-890B
----------------------	----------------	----------------------



## Standard Mechanical Configuration

Standard Mechanical Seal	SM, LG, & XL Bearing Frames	ES Bearing Frame
Temperature Range	-20 to 225°F	-20 to 225°F
Maximum Pressure	175 PSI	175 PSI
pH Limitations	7.0 - 9.0	7.0 - 9.0
Elastomer	Buna	Buna
Rotating Face	Carbon	Carbon
Stationary Face	Ceramic	Silicon Carbide
Hardware	Stainless Steel / Brass	Stainless Steel

Mechanical Seal Options	SM, LG, & XL Bearing Frames		
Temperature Range	-20 to 250°F	-10 to 225°F	-20 to 250°F
Maximum Pressure	175 PSI	175 PSI	175 PSI
pH Limitations	7.0 - 11.0	7.0 - 9.0	7.0 - 12.5.0
Elastomer	EPR (Ethylene Propylene Rubber)	FKM (Viton™ or Fluoroelastomer)	EPR (Ethylene Propylene Rubber)
Rotating Face	Carbon	Carbon	Silicon Carbide
Stationary Face	Tungsten Carbide	Ceramic	Silicon Carbide
Hardware	Stainless Steel / Brass	Stainless Steel	Stainless Steel

Mechanical Seal Options	ES Bearing Frame		
Temperature Range	-20 to 250°F	-10 to 225°F	-20 to 250°F
Maximum Pressure	175 PSI	175 PSI	175 PSI
pH Limitations	7.0 - 11.0	7.0 - 9.0	7.0 - 12.5.0
Elastomer	EPR (Ethylene Propylene Rubber)	FKM (Viton™ or Fluoroelastomer)	EPR (Ethylene Propylene Rubber)
Rotating Face	Silicon Carbide	Carbon	Silicon Carbide
Stationary Face	Tungsten Carbide	Silicon Carbide	Silicon Carbide
Hardware	Stainless Steel / Brass	Stainless Steel	Stainless Steel

## Stuffing Box Configuration

Mechanical Seal	SM, LG, & XL Bearing Frames
Temperature Range	-20 to 250°F*
Maximum Pressure	175 PSI (Optional 250 PSI)
pH Limitations	7.0 - 11.0
Elastomer	EPR (Ethylene Propylene Rubber)
Rotating Face	Tungsten Carbide
Stationary Face	Carbon
Hardware	Stainless Steel

Packing Option	
Temperature Range	0 to 250°F
Maximum Pressure	175 PSI
pH Limitations	7.0 - 9.0
Material	Braided Graphite Impregnated PTFE

\* For operating temperatures above 250°F a cooled flush is required and is recommended for temperatures above 225°F for optimum seal life. On closed systems cooling is accomplished by inserting a small heat-exchanger in the flush line to cool the seal flushing fluid.

Flush-line Filters and Sediment Separators are available on special request.

## Materials of Construction

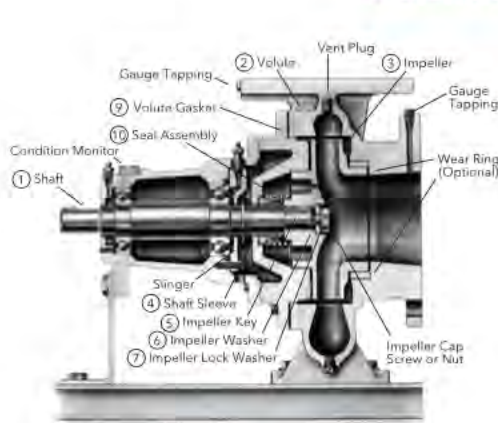

Standard Configuration

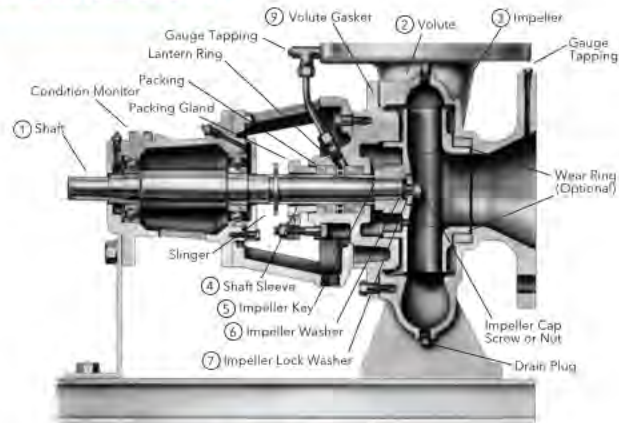

Optional - S Configuration

Description	SM, LG, & XL Bearing Frames	ES Bearing Frame
1 Shaft	ASTM 108 Grade 1144	ASTM 108 Grade 1144
2 Volute	Cast Iron ASTM A48 Class 30B	Cast Iron ASTM A48 Class 30B
3 Impeller	ASTM A743 Grade CF8 - 304 Stainless Steel	ASTM A743 Grade CF8 - 304 Stainless Steel
4 Shaft Sleeve	ASTM 312 Grade TP304 - 304 Stainless Steel	ASTM 312 Grade TP304 - 304 Stainless Steel
5 Impeller Key	#304 Stainless Steel	NA
6 Impeller Washer	Steel	NA
7 Impeller Lock Washer	#304 Stainless Steel (18-8 XL FRM)	NA
8 Impeller Cap Screw	#304 Stainless Steel	NA
8 Impeller Nut	NA	316 Stainless Steel
9 Volute Gasket	Cellulose Fiber	Cellulose Fiber
10 Seal Assembly	Reference Seal Data Tables	Reference Seal Data Tables

## Pump Options

- Stainless Steel Volute Wear Ring
- Galvanized Steel Drip Pan
- Stainless Steel Shaft
- Rexnord Omega Spacer Coupling
- Falk T31 Spacer Coupling
- External Flush Line
- Stuffing Box Configuration
- Epoxy Coated Internal Cast Iron Components
- Special Impeller Balancing (ISO 1940 G2.5 or G1.0)
- Certified Performance Tests (Per HI Standard 14.6)
- 250 PSI Working Pressure

Job/Project:		Representative: Wallace Eannace Associates	
ESP-Systemwize: WIZE-1B9F8771	Created On: 06/23/2023	Phone: (516) 454-9300	
Location/Tag:		Email: info-ny@wea-inc.com	
Engineer:	Submitted By:	Date:	
Contractor:	Approved By:	Date:	

### Base Mounted End Suction Pump

Series: e-1510

Model: 1.25AD-es

#### Features & Design

- ANSI/OSHA Coupling Guard
- Center Drop Out Spacer Coupling
- Fabricated Heavy Duty Baseplate
- Internally Self-Flushing Mechanical Seal



\*The Bell & Gossett Series e-1510 is available in 26 sizes and a variety of configuration options that enable customization and flexibility to fit a broad range of operating conditions.

<http://bellgossett.com/pumps-circulators/end-suction-pumps/e-1510/>

### Pump Selection Summary

Duty Point Flow	37.3 US gpm
Duty Point Head	45 ft
Control Head	13.5 ft
Duty Point Pump Efficiency	61 %
Part Load Efficiency Value (PLEV)	53.5 %
Impeller Diameter	6.875 in
Motor Power	1.5 hp
Duty Point Power	0.68 bhp
Motor Speed	1800 rpm
RPM @ Duty Point	1610 rpm
NPSHr	2.73 ft
Minimum Shutoff Head	46.2 ft
Minimum Flow at RPM	8.4 US gpm
Flow @ BEP	56 US gpm
Fluid Temperature	120 °F
Fluid Type	Water
Weight (approx. - consult rep for exact)	150 lbs
Pump Floor Space Calculation	2.64 ft <sup>2</sup>

### Performance Curve

#### Energy Efficiency Ratings:

Pump & Motor PEIc: 0.78 ERcI: 22  
Pump, Motor & Drive: PEIv: 0.44 ERvI: 56



**e-1510**  
**1.25AD-es**  
**1610 RPM**

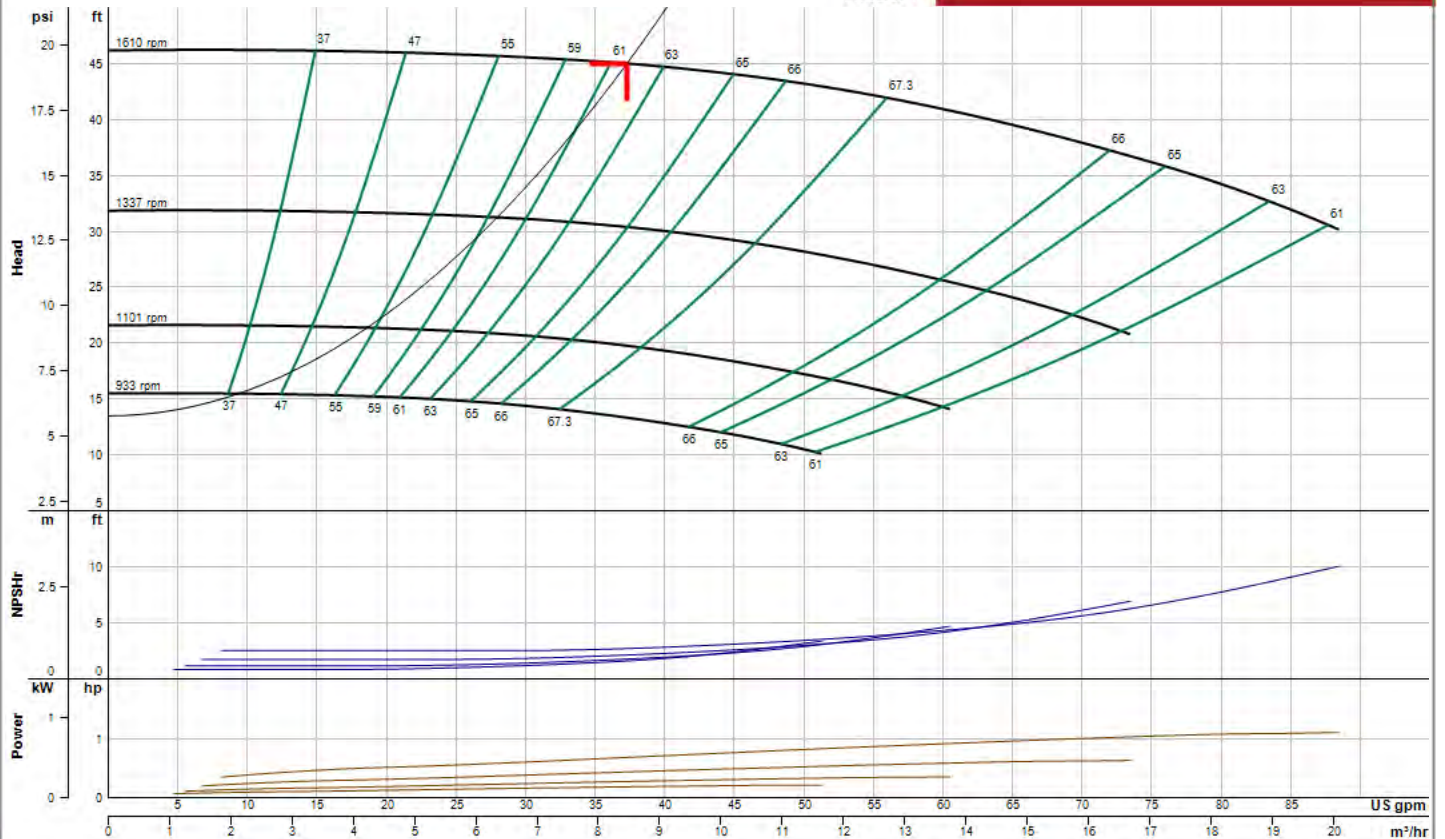



# Constant Speed Curve (1750 rpm)

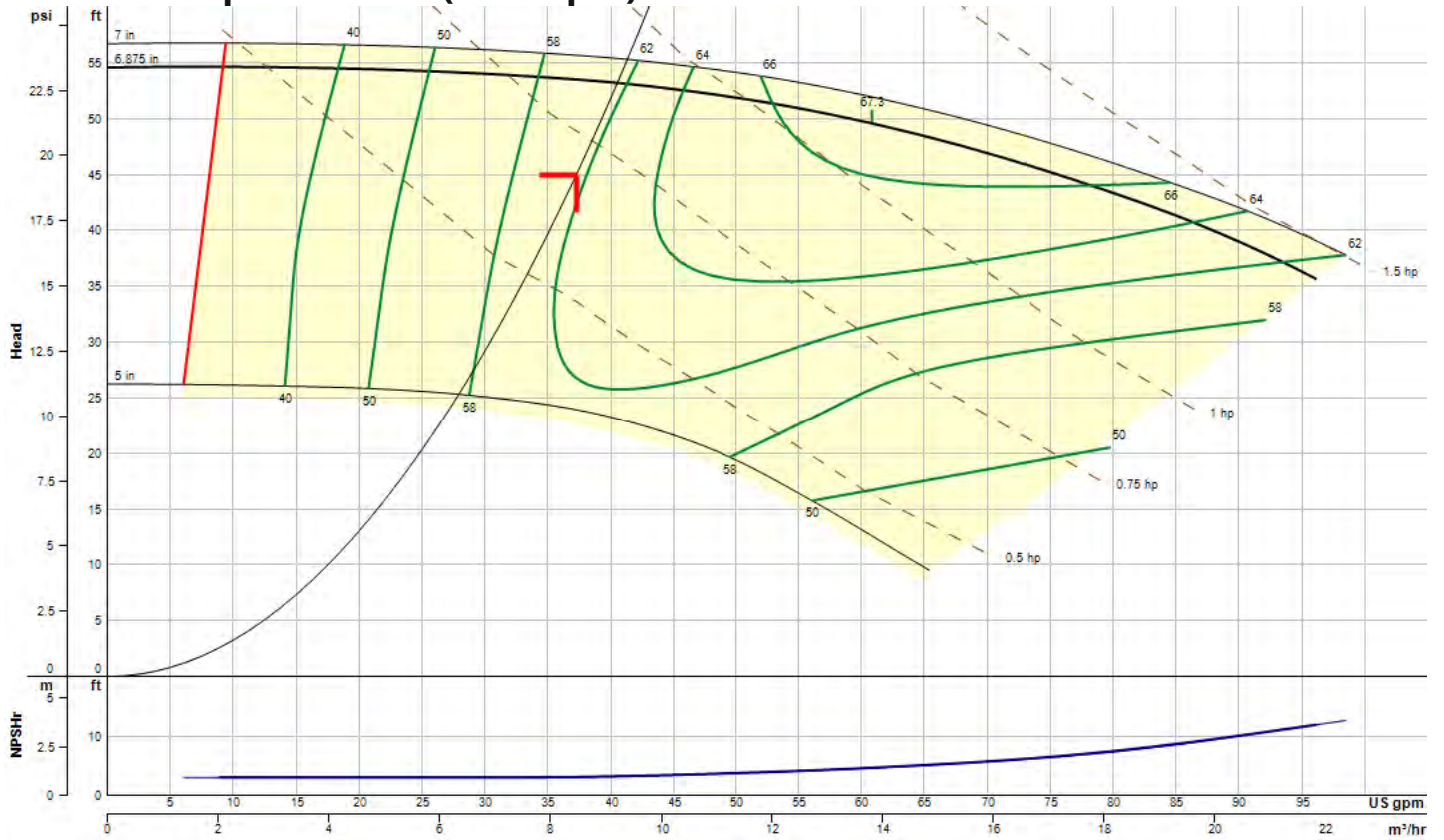

## Operating Point

Flow: 37.3 US gpm Head: 45 ft Speed: 1610 Efficiency: 61% Point BHP: 0.68 End Of Curve: 42.1%

## Maximum Duty Point (at rated motor speed)

Flow: 40.5 US gpm Head: 53.2 ft Speed: 1750 Efficiency: 61.6% Point BHP: 0.874 NOL Flow: 96.2 US gpm Runout Flow: 96.2 US gpm NOL (BHP): 1.42



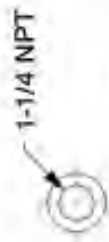

1-1/4 NPT DISCHARGE  
DETAILS

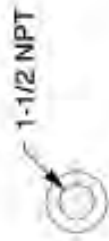

1-1/2 NPT SUCTION  
DETAILS

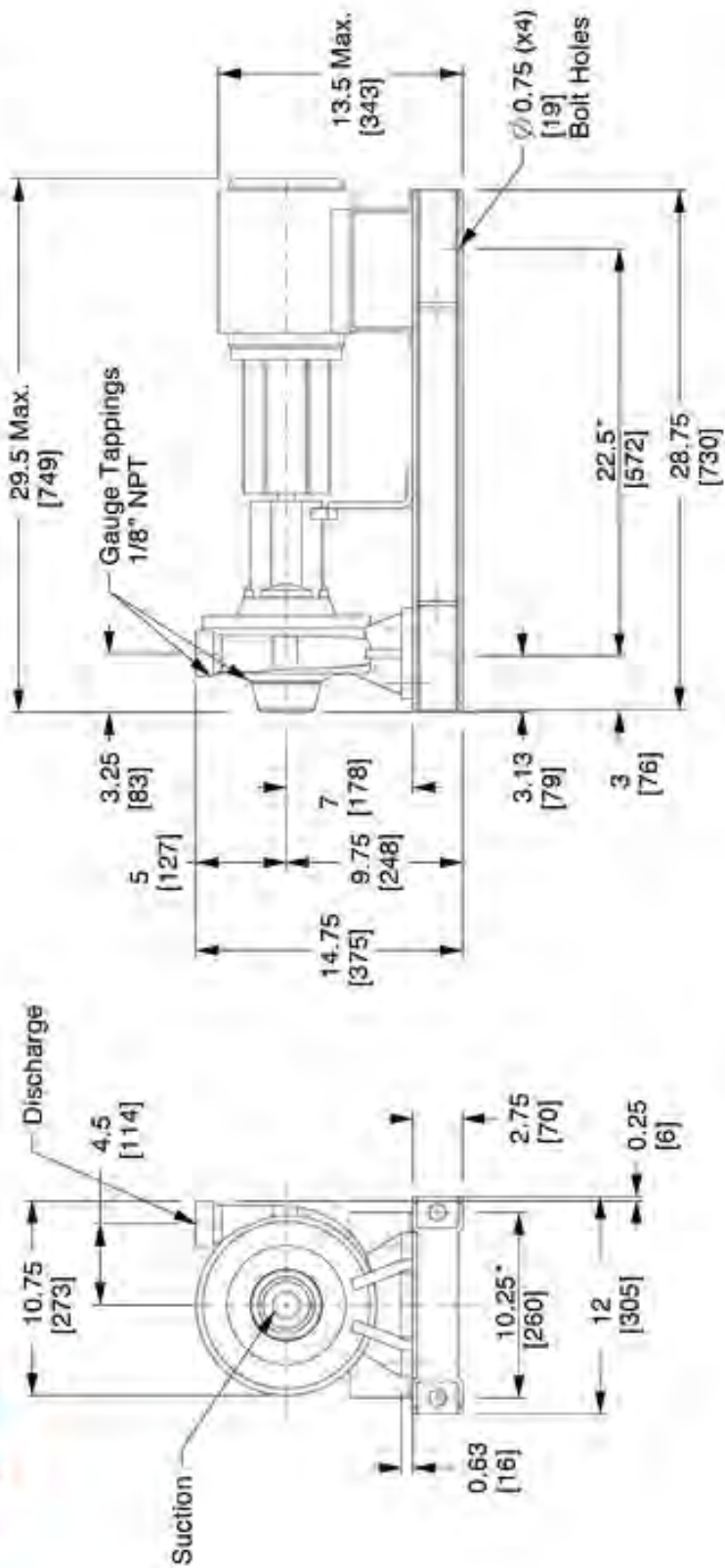

\* Dist. Between Bolt Holes

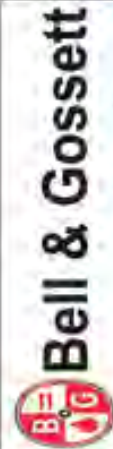

a xylem brand

8200 N. Austin Ave.  
Morton Grove, IL 60053, USA

## BG-E1510-1P25ADES-SS-145T

Series e-1510 Centrifugal Pumps - Base Mounted

Seal Type: Standard Seal | Motor Frame: 145T | Frame Type: eS

This drawing and the information depicted therein is the property of Xylem. Copies are issued in strict confidence and shall not be reproduced or copied, or used as the basis for the manufacture or sale of products without prior written permission of Xylem.

Dimensions are subject to change  
Not to be used for construction unless certified

Dimensions : IN (mm)

Scale : N.T.S.

Submittal # : B-890B

## Standard Mechanical Configuration

Standard Mechanical Seal	SM, LG, & XL Bearing Frames	ES Bearing Frame
Temperature Range	-20 to 225°F	-20 to 225°F
Maximum Pressure	175 PSI	175 PSI
pH Limitations	7.0 - 9.0	7.0 - 9.0
Elastomer	Buna	Buna
Rotating Face	Carbon	Carbon
Stationary Face	Ceramic	Silicon Carbide
Hardware	Stainless Steel / Brass	Stainless Steel

Mechanical Seal Options	SM, LG, & XL Bearing Frames		
Temperature Range	-20 to 250°F	-10 to 225°F	-20 to 250°F
Maximum Pressure	175 PSI	175 PSI	175 PSI
pH Limitations	7.0 - 11.0	7.0 - 9.0	7.0 - 12.5.0
Elastomer	EPR (Ethylene Propylene Rubber)	FKM (Viton™ or Fluoroelastomer)	EPR (Ethylene Propylene Rubber)
Rotating Face	Carbon	Carbon	Silicon Carbide
Stationary Face	Tungsten Carbide	Ceramic	Silicon Carbide
Hardware	Stainless Steel / Brass	Stainless Steel	Stainless Steel

Mechanical Seal Options	ES Bearing Frame		
Temperature Range	-20 to 250°F	-10 to 225°F	-20 to 250°F
Maximum Pressure	175 PSI	175 PSI	175 PSI
pH Limitations	7.0 - 11.0	7.0 - 9.0	7.0 - 12.5.0
Elastomer	EPR (Ethylene Propylene Rubber)	FKM (Viton™ or Fluoroelastomer)	EPR (Ethylene Propylene Rubber)
Rotating Face	Silicon Carbide	Carbon	Silicon Carbide
Stationary Face	Tungsten Carbide	Silicon Carbide	Silicon Carbide
Hardware	Stainless Steel / Brass	Stainless Steel	Stainless Steel

## Stuffing Box Configuration

Mechanical Seal	SM, LG, & XL Bearing Frames
Temperature Range	-20 to 250°F*
Maximum Pressure	175 PSI (Optional 250 PSI)
pH Limitations	7.0 - 11.0
Elastomer	EPR (Ethylene Propylene Rubber)
Rotating Face	Tungsten Carbide
Stationary Face	Carbon
Hardware	Stainless Steel

Packing Option	
Temperature Range	0 to 250°F
Maximum Pressure	175 PSI
pH Limitations	7.0 - 9.0
Material	Braided Graphite Impregnated PTFE

\* For operating temperatures above 250°F a cooled flush is required and is recommended for temperatures above 225°F for optimum seal life. On closed systems cooling is accomplished by inserting a small heat-exchanger in the flush line to cool the seal flushing fluid.

Flush-line Filters and Sediment Separators are available on special request.

## Materials of Construction

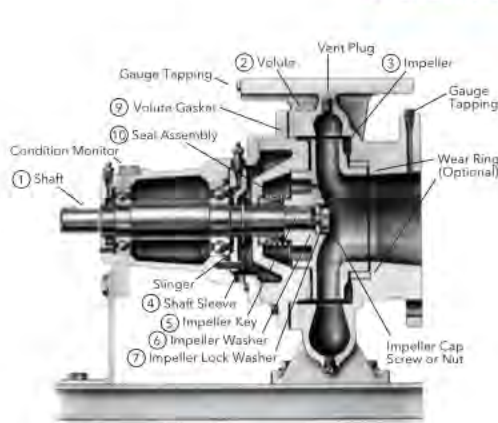

Standard Configuration

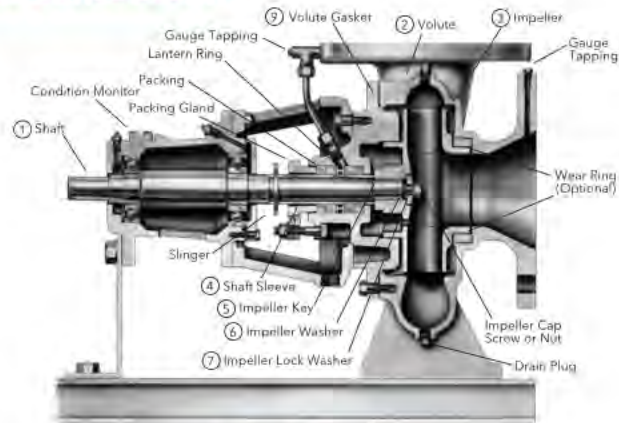

Optional - S Configuration

Description	SM, LG, & XL Bearing Frames	ES Bearing Frame
1 Shaft	ASTM 108 Grade 1144	ASTM 108 Grade 1144
2 Volute	Cast Iron ASTM A48 Class 30B	Cast Iron ASTM A48 Class 30B
3 Impeller	ASTM A743 Grade CF8 - 304 Stainless Steel	ASTM A743 Grade CF8 - 304 Stainless Steel
4 Shaft Sleeve	ASTM 312 Grade TP304 - 304 Stainless Steel	ASTM 312 Grade TP304 - 304 Stainless Steel
5 Impeller Key	#304 Stainless Steel	NA
6 Impeller Washer	Steel	NA
7 Impeller Lock Washer	#304 Stainless Steel (18-8 XL FRM)	NA
8 Impeller Cap Screw	#304 Stainless Steel	NA
8 Impeller Nut	NA	316 Stainless Steel
9 Volute Gasket	Cellulose Fiber	Cellulose Fiber
10 Seal Assembly	Reference Seal Data Tables	Reference Seal Data Tables

## Pump Options

- Stainless Steel Volute Wear Ring
- Galvanized Steel Drip Pan
- Stainless Steel Shaft
- Rexnord Omega Spacer Coupling
- Falk T31 Spacer Coupling
- External Flush Line
- Stuffing Box Configuration
- Epoxy Coated Internal Cast Iron Components
- Special Impeller Balancing (ISO 1940 G2.5 or G1.0)
- Certified Performance Tests (Per HI Standard 14.6)
- 250 PSI Working Pressure





## Hybrid Split-System Vertical Stack Fan Coil



APARTMENTS | CONDOS | ASSISTED LIVING | HOTELS | RESORTS

**PRODUCT SPECIFICATIONS – HYBRID  
AVAILABLE EARLY 2018**

## Component Diagram

Series - DX

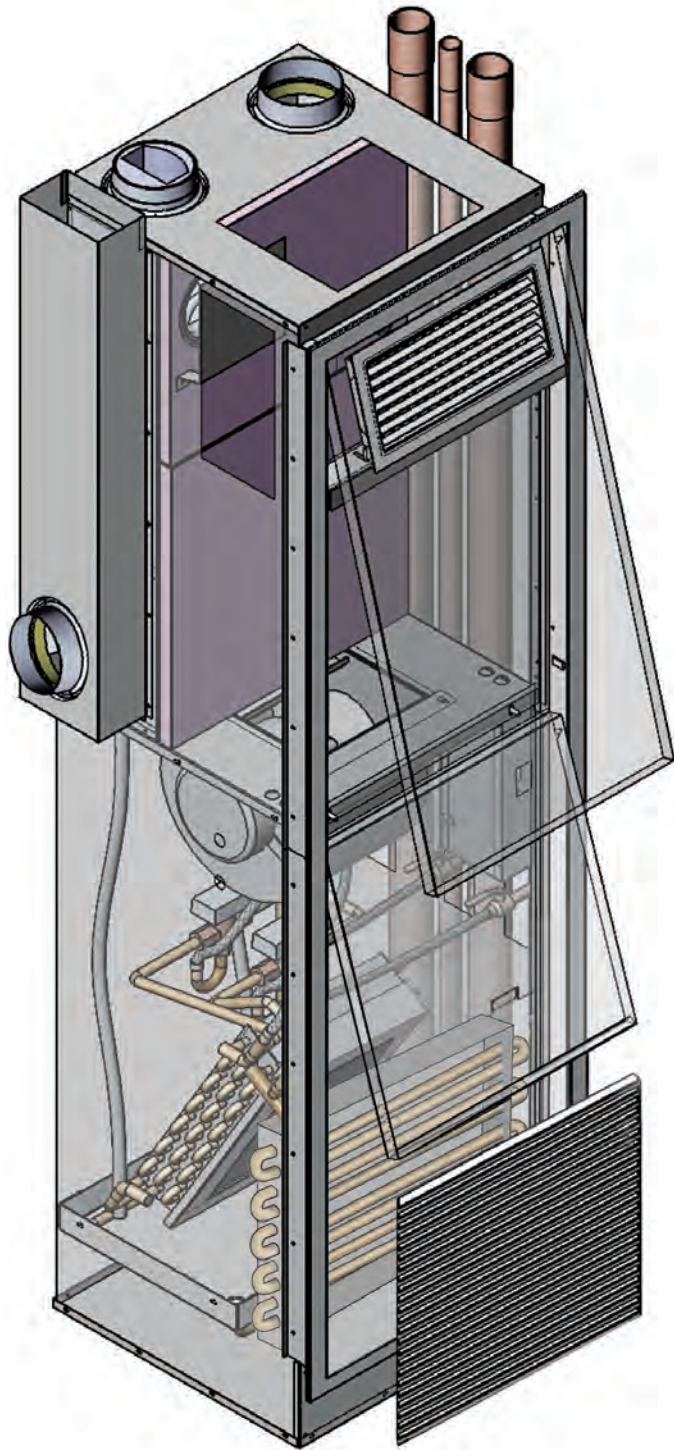

## Designed for Efficiency and Performance

Unilux VFC is again first to the market with a new hybrid vertical stack fan coil product for the high-rise residential marketplace.

Heat is provided to the suite through a building-wide hot water system, providing heat using the highly-efficient and reliable hydronic solution.

Cooling is provided through an eco-friendly refrigerant-charged evaporated-cooling coil mounted in the vertical stack fan coil and paired with an external condensing unit located outside of the suite (typically on a balcony).

The unit is controlled by a specially designed microprocessor which is housed inside the vertical stack fan coil. The controller is Wi-Fi-enabled, thus all HVAC controls can be accessed by the resident anywhere via a smartphone, tablet or computer.

The Unilux hybrid VFC can be further enhanced with the addition of an integrated heat recovery ventilator to provide fresh air to each suite using the energy in the exhaust air to reduce energy costs.





Unilux VFC has been building vertical stack fan coil products for the North American high-rise residential market for almost 50 years. Our products are highly durable, with top of the line components and the latest control technologies available. We pride ourselves on being market leaders in product development and consider the Hybrid VFC to be an excellent product for many applications.

#### Hybrid VFC benefits

- Highly-efficient and reliable heating using hydronics
- Effective proven cooling technology
- Compressor located outside of suite, providing a much quieter environment
- Rugged, reliable products, low maintenance, inexpensive to service and maintain
- Eliminate need for building-wide cool water system and chillers
- Resident has complete control of cooling and cost management
- Extremely cost effective over full life of system

Visit [www.uniluxvfc.com](http://www.uniluxvfc.com) for details on Wi-Fi-enabled controller and integrated ERV/HRV options.



# Standard Features

## Model DX

### 1. Cabinet:

18-gauge satin coat steel. Cabinet is fully insulated with ½" fiberglass bonded with a thermosetting resin and coated on the airstream side with an acrylic facing, without the use of flammable adhesives. Insulation inside the unit: Flame spread rating no more than 25; Smoke developed rating no more than 50. The cabinet's footprint is 21"x21".

### 2. Coil assembly:

The coil's corrugated aluminum fins mechanically bonded to 3/8" OD Copper tube. The number of rows and circuiting are selected to suit scheduled capacities. Coils have a minimum working pressure of 300 psig (tested to 450 psig) and can handle heating up to 50,000 BTUH.

### 3. Fan assembly:

A thermally protected ECM motor is resiliently mounted to a centrifugal fan which has a galvanized steel forward curved DWDI wheel in a painted housing. Available CFM - 350, 450, 600, 800, 1000 and 1200.

### 4. Hot water piping branches:

Are constructed with ½" type "L" copper, and stainless steel braided flex hoses to provide expansion and contraction of risers; include shut-off ball valves with flare nuts in the supply and return branches for easy removal.

### 5. Risers:

Supply and return risers are type 'L' copper and condensate risers are type 'DWV' copper. All have 75 mm (3") deep expanded ends to facilitate field installation. Supply & Return risers are insulated with 1" fiberglass covered with vapour barrier jacket, which complies with ASTM 84 for flame-spread and smoke-developed ratings. The insulation is continuous over the riser length within the height of the cabinet.

### 6. Control valve package:

Provides a standard factory assembled 2-way control valve with flare nuts connection to piping branches to facilitate easy removal without using torch or pipe cutters, motorized electrical "on/off" controlling. Control valves are piped normally-closed to the coil. Provide 3-way motorized valves on top of each riser if main supply is on ground level, or provide 3-way motorized valves on bottom of each riser if main supply is on top level. Maximum entering water temperature on the control valve shall be 200°F, and maximum operating pressure shall be 300 psig.

### 7. Evaporator Coil:

Coil to be r-410a AC compatible, high-efficiency fin design with downflow drip shield molded into the drain pan. Coils are air pressure tested to 600 psi, and come sealed with rubber plugs and charged with nitrogen. Copper refrigerant connections for easy braising, copper tubing. Cooling up to 3 tons.

### 8. Access panel:

Access panel assembly is constructed of 20 gauge steel complete with a durable baked enamel powder finish, with integral grille for the return air opening. The panel is hinged removable to allow for easy filter exchange. The integral core grille has fixed horizontal louvers.

### 9. Grilles and registers:

Double deflection supply grilles and registers have adjustable vertical or horizontal louvers. Registers constructed with light gauge steel complete with adjustable opposed blade dampers.

### 10. Control arrangement:

Complete with an un-fused disconnect switch in compliance with the electrical load. Includes a 24v thermostat featuring digital display, 3-speed fan switch, fan on/auto switch. System controls the different options of sequence of operation for the cycling of motorized valves, fan, and heating element. State-of-the-art on-board microprocessor controls system operation. Wall pad, Wi-Fi-enabled and programmable thermostat options available.

### 11. Filters:

A 1" disposable throwaway type filter is included with the return air grille.

### 12. Air-to-Air AC unit:

Compact external air-to-air air-conditioning unit to be supplied by others.

### 13. Available with integrated HRV or ERV.

1.2 - Village Hall Terminal Condensing Units

**SAMSUNG**

**FJM**

# Technical Data Book

Free Joint Multi for America  
Capacity Table



Model : Outdoor unit: JXH\*\*S\*T (AJ\*\*\*TXS\*CH/AA)

# History

---

Version	Modification	Date	Remark
Ver.1.0	Released FJM Capacity for America (Low Ambi. 60Hz, HP) TDB	20.04.03	

# Capacity Table

JXH36S4T(AJ036TXS4CH/AA)

Cooling(Ducted)

Combination (Capacity Index)				Combination (Total)	Outdoor Temperature (°F,DB)	Indoor Temperature(°F, WB)											
						57.2		60.8		64.4		67		71.6		75.2	
						TC(kW)	PI(kW)	TC(kW)	PI(kW)	TC(kW)	PI(kW)	TC(kW)	PI(kW)	TC(kW)	PI(kW)	TC(kW)	PI(kW)
9				9	68	7.20	0.57	9.60	0.61	10.03	0.65	10.24	0.67	10.89	0.70	11.32	0.71
					70	7.20	0.58	9.52	0.62	9.95	0.66	10.16	0.67	10.80	0.71	11.23	0.72
					73	7.20	0.61	9.36	0.65	9.78	0.68	9.99	0.69	10.63	0.72	11.06	0.73
					77	7.20	0.63	9.20	0.67	9.61	0.70	9.82	0.71	10.46	0.74	10.89	0.75
					81	7.20	0.65	9.03	0.69	9.45	0.72	9.66	0.73	10.29	0.76	10.71	0.76
					84	7.20	0.68	8.87	0.71	9.28	0.74	9.49	0.75	10.12	0.77	10.54	0.78
					88	7.20	0.70	8.71	0.73	9.12	0.76	9.33	0.77	9.95	0.79	10.37	0.79
					91	7.20	0.72	8.55	0.76	8.96	0.78	9.16	0.79	9.78	0.81	10.20	0.81
					95	7.20	0.75	8.39	0.78	8.79	0.80	9.00	0.80	9.61	0.83	10.02	0.83
					99	7.20	0.77	8.23	0.80	8.63	0.82	8.83	0.83	9.44	0.84	9.85	0.84
					102	7.20	0.80	8.07	0.83	8.47	0.85	8.67	0.85	9.28	0.86	9.68	0.86
					108	7.11	0.84	7.83	0.86	8.23	0.88	8.42	0.88	9.03	0.89	9.43	0.88
					111	6.75	0.86	7.67	0.89	8.07	0.90	8.26	0.91	8.86	0.91	9.26	0.90
					115	6.57	0.89	7.52	0.91	7.90	0.93	8.10	0.93	8.69	0.93	9.09	0.92
12				12	68	9.60	0.78	12.81	0.84	13.37	0.89	13.66	0.91	14.52	0.95	15.09	0.97
					70	9.60	0.79	12.70	0.85	13.26	0.90	13.54	0.92	14.40	0.96	14.98	0.98
					73	9.60	0.82	12.48	0.88	13.04	0.93	13.32	0.94	14.17	0.99	14.75	1.00
					77	9.60	0.86	12.26	0.91	12.82	0.95	13.10	0.97	13.95	1.01	14.51	1.02
					81	9.60	0.89	12.04	0.94	12.60	0.98	12.88	1.00	13.72	1.03	14.28	1.04
					84	9.60	0.92	11.83	0.97	12.38	1.01	12.66	1.02	13.49	1.05	14.05	1.06
					88	9.60	0.95	11.61	1.00	12.16	1.04	12.43	1.05	13.27	1.08	13.82	1.08
					91	9.60	0.99	11.40	1.03	11.94	1.06	12.21	1.08	13.04	1.10	13.59	1.10
					95	9.60	1.02	11.19	1.06	11.72	1.09	12.00	1.09	12.81	1.12	13.37	1.12
					99	9.60	1.05	10.97	1.09	11.51	1.12	11.78	1.13	12.59	1.15	13.14	1.15
					102	9.60	1.09	10.76	1.13	11.29	1.15	11.56	1.16	12.37	1.17	12.91	1.17
					108	9.48	1.14	10.44	1.17	10.97	1.20	11.23	1.21	12.03	1.21	12.57	1.21
					111	9.00	1.18	10.23	1.21	10.75	1.23	11.02	1.24	11.81	1.24	12.35	1.23
					115	8.76	1.21	10.02	1.24	10.54	1.26	10.80	1.27	11.59	1.27	12.12	1.25
18				18	68	13.68	1.06	18.25	1.14	19.05	1.20	19.46	1.23	20.69	1.29	21.51	1.32
					70	13.68	1.08	18.09	1.16	18.90	1.22	19.30	1.25	20.52	1.31	21.34	1.33
					73	13.68	1.12	17.78	1.20	18.58	1.26	18.98	1.28	20.20	1.34	21.01	1.36
					77	13.68	1.16	17.47	1.23	18.27	1.29	18.67	1.32	19.87	1.37	20.68	1.38
					81	13.68	1.21	17.16	1.27	17.95	1.33	18.35	1.35	19.55	1.40	20.35	1.41
					84	13.68	1.25	16.86	1.32	17.64	1.37	18.03	1.39	19.22	1.43	20.03	1.44
					88	13.68	1.29	16.55	1.36	17.33	1.41	17.72	1.42	18.90	1.46	19.70	1.47
					91	13.68	1.34	16.24	1.40	17.02	1.44	17.41	1.46	18.58	1.49	19.37	1.50
					95	13.68	1.38	15.94	1.44	16.71	1.48	17.10	1.48	18.26	1.53	19.05	1.53
					99	13.68	1.43	15.63	1.48	16.40	1.52	16.78	1.54	17.94	1.56	18.72	1.56
					102	13.68	1.48	15.33	1.53	16.09	1.56	16.47	1.58	17.62	1.59	18.40	1.59
					108	13.51	1.55	14.88	1.60	15.63	1.63	16.01	1.64	17.15	1.65	17.92	1.64
					111	12.83	1.60	14.58	1.64	15.32	1.67	15.70	1.68	16.83	1.68	17.59	1.67
					115	12.48	1.65	14.28	1.69	15.02	1.71	15.39	1.72	16.52	1.72	17.27	1.70

# Capacity Table

JXH36S4T(AJ036TXS4CH/AA)

Cooling(Ducted)

Combination (Capacity Index)				Combination (Total)	Outdoor Temperature (°F, DB)	Indoor Temperature(°F, WB)											
						57.2		60.8		64.4		67		71.6		75.2	
						TC(kW)	PI(kW)	TC(kW)	PI(kW)	TC(kW)	PI(kW)	TC(kW)	PI(kW)	TC(kW)	PI(kW)	TC(kW)	PI(kW)
9	9			18	68	15.91	1.07	19.64	1.10	20.22	1.12	20.55	1.13	21.72	1.16	22.65	1.18
					70	15.91	1.09	19.39	1.11	19.99	1.13	20.33	1.15	21.52	1.18	22.46	1.20
					73	15.91	1.12	18.92	1.14	19.54	1.16	19.90	1.17	21.14	1.20	22.11	1.22
					77	15.91	1.14	18.47	1.17	19.13	1.19	19.50	1.20	20.79	1.23	21.79	1.25
					81	15.91	1.17	18.05	1.20	18.74	1.22	19.12	1.23	20.46	1.26	21.49	1.28
					84	15.91	1.20	17.65	1.23	18.37	1.25	18.77	1.26	20.15	1.29	21.22	1.31
					88	15.91	1.23	17.28	1.26	18.03	1.28	18.45	1.29	19.87	1.32	20.97	1.34
					91	15.91	1.27	16.93	1.29	17.71	1.31	18.14	1.32	19.62	1.35	20.75	1.37
					95	15.91	1.30	16.61	1.32	17.42	1.34	18.00	1.35	19.39	1.38	20.55	1.40
					99	15.91	1.33	16.31	1.35	17.15	1.38	17.62	1.39	19.18	1.42	20.37	1.44
					102	15.91	1.36	16.03	1.39	16.91	1.41	17.39	1.42	19.01	1.45	20.22	1.47
					108	15.91	1.42	15.67	1.44	16.59	1.46	17.10	1.47	18.78	1.50	20.05	1.52
					111	15.91	1.45	15.46	1.47	16.42	1.49	16.93	1.51	18.67	1.54	19.96	1.56
115	15.91	1.49	15.28	1.51	16.26	1.53	16.80	1.54	18.57	1.57	19.90	1.59					
9	12			21	68	18.56	1.24	22.91	1.27	23.59	1.30	23.97	1.31	25.34	1.35	26.42	1.37
					70	18.56	1.26	22.62	1.28	23.32	1.31	23.71	1.32	25.11	1.36	26.21	1.38
					73	18.56	1.29	22.07	1.32	22.80	1.34	23.22	1.36	24.67	1.39	25.80	1.42
					77	18.56	1.32	21.55	1.35	22.32	1.38	22.75	1.39	24.25	1.42	25.42	1.45
					81	18.56	1.36	21.05	1.38	21.86	1.41	22.31	1.42	23.87	1.46	25.07	1.48
					84	18.56	1.39	20.59	1.42	21.43	1.44	21.90	1.46	23.51	1.49	24.75	1.52
					88	18.56	1.43	20.16	1.45	21.03	1.48	21.52	1.49	23.19	1.53	24.46	1.55
					91	18.56	1.46	19.75	1.49	20.66	1.51	21.17	1.53	22.89	1.56	24.20	1.59
					95	18.56	1.50	19.37	1.53	20.32	1.55	21.00	1.56	22.62	1.60	23.97	1.62
					99	18.56	1.54	19.03	1.56	20.01	1.59	20.55	1.60	22.38	1.64	23.77	1.66
					102	18.56	1.58	18.71	1.60	19.73	1.63	20.29	1.64	22.17	1.68	23.60	1.70
					108	18.56	1.64	18.28	1.66	19.36	1.69	19.95	1.70	21.91	1.73	23.39	1.76
					111	18.56	1.68	18.04	1.70	19.15	1.73	19.76	1.74	21.78	1.77	23.29	1.80
115	18.56	1.72	17.82	1.74	18.97	1.77	19.60	1.78	21.67	1.82	23.22	1.84					
9	18			27	68	23.07	1.80	28.47	1.84	29.31	1.88	29.80	1.90	31.50	1.95	32.84	1.98
					70	23.07	1.82	28.12	1.86	28.98	1.90	29.47	1.92	31.21	1.97	32.57	2.01
					73	23.07	1.87	27.43	1.91	28.34	1.95	28.86	1.96	30.66	2.02	32.06	2.05
					77	23.07	1.92	26.78	1.96	27.73	1.99	28.27	2.01	30.14	2.06	31.60	2.10
					81	23.07	1.96	26.17	2.00	27.17	2.04	27.73	2.06	29.66	2.11	31.16	2.15
					84	23.07	2.01	25.59	2.05	26.63	2.09	27.22	2.11	29.22	2.16	30.77	2.20
					88	23.07	2.07	25.05	2.10	26.14	2.14	26.75	2.16	28.82	2.21	30.41	2.25
					91	23.07	2.12	24.55	2.16	25.68	2.19	26.31	2.21	28.45	2.26	30.08	2.30
					95	23.07	2.17	24.08	2.21	25.26	2.25	26.10	2.26	28.11	2.32	29.79	2.35
					99	23.07	2.23	23.65	2.27	24.87	2.30	25.54	2.32	27.82	2.37	29.54	2.40
					102	23.07	2.28	23.25	2.32	24.52	2.36	25.22	2.38	27.56	2.43	29.33	2.46
					108	23.07	2.37	22.73	2.41	24.06	2.44	24.79	2.46	27.23	2.51	29.07	2.54
					111	23.07	2.43	22.42	2.47	23.80	2.50	24.56	2.52	27.07	2.57	28.95	2.60
115	23.07	2.49	22.15	2.53	23.58	2.56	24.35	2.58	26.93	2.63	28.86	2.66					



# Capacity Table

JXH36S4T(AJ036TXS4CH/AA)

Cooling(Ducted)

Combination (Capacity Index)				Combination (Total)	Outdoor Temperature (°F, DB)	Indoor Temperature(°F, WB)											
						57.2		60.8		64.4		67		71.6		75.2	
						TC(kW)	PI(kW)	TC(kW)	PI(kW)	TC(kW)	PI(kW)	TC(kW)	PI(kW)	TC(kW)	PI(kW)	TC(kW)	PI(kW)
12	12			24	68	21.21	1.41	26.18	1.44	26.96	1.47	27.40	1.48	28.96	1.53	30.19	1.55
					70	21.21	1.43	25.85	1.46	26.65	1.49	27.10	1.50	28.70	1.54	29.95	1.57
					73	21.21	1.46	25.22	1.49	26.06	1.52	26.53	1.54	28.19	1.58	29.48	1.61
					77	21.21	1.50	24.63	1.53	25.50	1.56	26.00	1.58	27.72	1.62	29.05	1.64
					81	21.21	1.54	24.06	1.57	24.98	1.60	25.50	1.61	27.28	1.65	28.66	1.68
					84	21.21	1.58	23.53	1.61	24.49	1.64	25.03	1.65	26.87	1.69	28.29	1.72
					88	21.21	1.62	23.03	1.65	24.04	1.68	24.59	1.69	26.50	1.73	27.96	1.76
					91	21.21	1.66	22.57	1.69	23.61	1.72	24.19	1.73	26.16	1.77	27.66	1.80
					95	21.21	1.70	22.14	1.73	23.22	1.76	24.00	1.77	25.85	1.81	27.40	1.84
					99	21.21	1.74	21.74	1.77	22.87	1.80	23.49	1.82	25.58	1.86	27.16	1.88
					102	21.21	1.79	21.38	1.82	22.55	1.85	23.19	1.86	25.34	1.90	26.97	1.93
					108	21.21	1.86	20.90	1.89	22.13	1.91	22.80	1.93	25.04	1.97	26.73	1.99
111	21.21	1.90	20.62	1.93	21.89	1.96	22.58	1.97	24.89	2.01	26.62	2.04					
115	21.21	1.95	20.37	1.98	21.68	2.01	22.39	2.02	24.76	2.06	26.54	2.09					
12	18			30	68	25.72	2.04	31.75	2.08	32.68	2.13	33.22	2.15	35.12	2.21	36.61	2.25
					70	25.72	2.06	31.35	2.11	32.31	2.15	32.86	2.17	34.79	2.23	36.31	2.27
					73	25.72	2.12	30.58	2.16	31.60	2.20	32.17	2.22	34.18	2.28	35.75	2.32
					77	25.72	2.17	29.86	2.21	30.92	2.26	31.52	2.28	33.61	2.34	35.23	2.38
					81	25.72	2.23	29.18	2.27	30.29	2.31	30.92	2.33	33.07	2.39	34.74	2.43
					84	25.72	2.28	28.53	2.33	29.70	2.37	30.35	2.39	32.58	2.45	34.30	2.49
					88	25.72	2.34	27.93	2.38	29.14	2.43	29.82	2.45	32.13	2.51	33.90	2.54
					91	25.72	2.40	27.37	2.44	28.63	2.49	29.33	2.51	31.72	2.56	33.54	2.60
					95	25.72	2.46	26.85	2.50	28.16	2.55	29.10	2.56	31.35	2.62	33.22	2.66
					99	25.72	2.52	26.36	2.57	27.73	2.61	28.48	2.63	31.02	2.69	32.94	2.72
					102	25.72	2.59	25.92	2.63	27.34	2.67	28.11	2.69	30.72	2.75	32.70	2.79
					108	25.72	2.68	25.34	2.73	26.83	2.77	27.64	2.79	30.37	2.85	32.41	2.88
111	25.72	2.75	25.00	2.79	26.54	2.83	27.38	2.85	30.18	2.91	32.27	2.95					
115	25.72	2.82	24.70	2.86	26.29	2.90	27.15	2.92	30.03	2.98	32.18	3.02					
18	18			36	68	30.22	2.47	37.31	2.52	38.41	2.57	39.04	2.60	41.27	2.67	43.03	2.72
					70	30.22	2.50	36.84	2.55	37.97	2.61	38.62	2.63	40.89	2.70	42.68	2.75
					73	30.22	2.56	35.94	2.62	37.13	2.67	37.81	2.69	40.17	2.77	42.02	2.81
					77	30.22	2.63	35.09	2.68	36.34	2.73	37.05	2.76	39.50	2.83	41.40	2.88
					81	30.22	2.70	34.29	2.75	35.60	2.80	36.33	2.82	38.87	2.90	40.83	2.94
					84	30.22	2.76	33.53	2.82	34.90	2.87	35.67	2.89	38.29	2.97	40.31	3.01
					88	30.22	2.83	32.82	2.89	34.25	2.94	35.05	2.96	37.76	3.03	39.84	3.08
					91	30.22	2.91	32.16	2.96	33.65	3.01	34.47	3.03	37.28	3.11	39.42	3.15
					95	30.22	2.98	31.55	3.03	33.10	3.08	34.20	3.10	36.84	3.18	39.04	3.22
					99	30.22	3.06	30.98	3.11	32.59	3.16	33.47	3.18	36.45	3.25	38.71	3.30
					102	30.22	3.13	30.47	3.18	32.13	3.23	33.04	3.26	36.11	3.33	38.43	3.37
					108	30.22	3.25	29.78	3.30	31.53	3.35	32.49	3.38	35.69	3.45	38.09	3.49
111	30.22	3.33	29.38	3.38	31.19	3.43	32.18	3.46	35.46	3.53	37.93	3.57					
115	30.22	3.41	29.03	3.47	30.90	3.52	31.91	3.54	35.29	3.61	37.81	3.65					

# Capacity Table

JXH36S4T(AJ036TXS4CH/AA)

Cooling(Ducted)

Combination (Capacity Index)				Combination (Total)	Outdoor Temperature (°F, DB)	Indoor Temperature(°F, WB)											
						57.2		60.8		64.4		67		71.6		75.2	
						TC(kW)	PI(kW)	TC(kW)	PI(kW)	TC(kW)	PI(kW)	TC(kW)	PI(kW)	TC(kW)	PI(kW)	TC(kW)	PI(kW)
9	9	9		27	68	23.86	2.01	29.45	2.06	30.32	2.10	30.82	2.12	32.58	2.18	33.97	2.22
					70	23.86	2.04	29.09	2.08	29.98	2.13	30.49	2.15	32.28	2.21	33.69	2.24
					73	23.86	2.09	28.38	2.14	29.32	2.18	29.85	2.20	31.71	2.26	33.17	2.30
					77	23.86	2.14	27.70	2.19	28.69	2.23	29.25	2.25	31.18	2.31	32.68	2.35
					81	23.86	2.20	27.07	2.24	28.10	2.29	28.68	2.31	30.69	2.36	32.24	2.40
					84	23.86	2.26	26.47	2.30	27.55	2.34	28.16	2.36	30.23	2.42	31.83	2.46
					88	23.86	2.31	25.91	2.36	27.04	2.40	27.67	2.42	29.81	2.48	31.45	2.51
					91	23.86	2.37	25.39	2.41	26.57	2.46	27.22	2.48	29.43	2.53	31.12	2.57
					95	23.86	2.43	24.91	2.47	26.13	2.52	27.00	2.53	29.08	2.59	30.82	2.63
					99	23.86	2.49	24.46	2.54	25.73	2.58	26.43	2.60	28.78	2.65	30.56	2.69
					102	23.86	2.56	24.05	2.60	25.37	2.64	26.09	2.66	28.51	2.72	30.34	2.75
					108	23.86	2.65	23.51	2.70	24.89	2.74	25.65	2.76	28.17	2.81	30.07	2.85
111	23.86	2.72	23.19	2.76	24.62	2.80	25.40	2.82	28.00	2.88	29.94	2.91					
115	23.86	2.79	22.92	2.83	24.39	2.87	25.19	2.89	27.86	2.94	29.85	2.98					
9	9	12		30	68	26.51	2.21	32.73	2.25	33.69	2.30	34.25	2.32	36.20	2.39	37.74	2.43
					70	26.51	2.23	32.32	2.28	33.31	2.33	33.88	2.35	35.87	2.42	37.44	2.46
					73	26.51	2.29	31.53	2.34	32.57	2.38	33.17	2.41	35.24	2.47	36.86	2.51
					77	26.51	2.35	30.78	2.40	31.88	2.44	32.50	2.46	34.65	2.53	36.32	2.57
					81	26.51	2.41	30.08	2.46	31.23	2.50	31.87	2.52	34.10	2.59	35.82	2.63
					84	26.51	2.47	29.42	2.52	30.61	2.56	31.29	2.59	33.59	2.65	35.36	2.69
					88	26.51	2.53	28.79	2.58	30.05	2.63	30.74	2.65	33.12	2.71	34.95	2.75
					91	26.51	2.60	28.21	2.64	29.52	2.69	30.24	2.71	32.70	2.78	34.58	2.82
					95	26.51	2.66	27.68	2.71	29.03	2.75	30.00	2.77	32.32	2.84	34.24	2.88
					99	26.51	2.73	27.18	2.78	28.59	2.82	29.36	2.84	31.97	2.91	33.96	2.95
					102	26.51	2.80	26.72	2.85	28.18	2.89	28.98	2.91	31.68	2.97	33.71	3.01
					108	26.51	2.90	26.12	2.95	27.66	3.00	28.50	3.02	31.30	3.08	33.42	3.12
111	26.51	2.98	25.77	3.02	27.36	3.07	28.22	3.09	31.11	3.15	33.27	3.19					
115	26.51	3.05	25.46	3.10	27.10	3.14	27.99	3.16	30.96	3.22	33.17	3.26					
9	9	18		36	68	30.05	2.46	37.09	2.51	38.19	2.57	38.82	2.59	41.03	2.66	42.78	2.71
					70	30.05	2.49	36.63	2.54	37.75	2.60	38.40	2.62	40.65	2.69	42.43	2.74
					73	30.05	2.55	35.73	2.61	36.92	2.66	37.59	2.68	39.94	2.76	41.77	2.80
					77	30.05	2.62	34.89	2.67	36.13	2.72	36.83	2.75	39.27	2.82	41.16	2.87
					81	30.05	2.69	34.09	2.74	35.39	2.79	36.12	2.82	38.64	2.89	40.59	2.93
					84	30.05	2.75	33.34	2.81	34.70	2.86	35.46	2.88	38.07	2.96	40.08	3.00
					88	30.05	2.83	32.63	2.88	34.05	2.93	34.84	2.95	37.54	3.02	39.61	3.07
					91	30.05	2.90	31.98	2.95	33.45	3.00	34.27	3.02	37.06	3.10	39.19	3.14
					95	30.05	2.97	31.37	3.02	32.90	3.07	34.00	3.09	36.62	3.17	38.81	3.21
					99	30.05	3.05	30.80	3.10	32.40	3.15	33.28	3.17	36.24	3.24	38.48	3.29
					102	30.05	3.12	30.29	3.17	31.94	3.22	32.85	3.25	35.90	3.32	38.20	3.36
					108	30.05	3.24	29.60	3.29	31.34	3.34	32.30	3.37	35.48	3.44	37.87	3.48
111	30.05	3.32	29.21	3.37	31.01	3.42	31.99	3.45	35.26	3.52	37.71	3.56					
115	30.05	3.40	28.86	3.45	30.72	3.50	31.73	3.53	35.08	3.60	37.59	3.64					

# Capacity Table

JXH36S4T(AJ036TXS4CH/AA)

Cooling(Ducted)

Combination (Capacity Index)				Combination (Total)	Outdoor Temperature (°F, DB)	Indoor Temperature(°F, WB)											
						57.2		60.8		64.4		67		71.6		75.2	
						TC(kW)	PI(kW)	TC(kW)	PI(kW)	TC(kW)	PI(kW)	TC(kW)	PI(kW)	TC(kW)	PI(kW)	TC(kW)	PI(kW)
9	12	12	33	68	29.16	2.40	36.00	2.45	37.06	2.50	37.67	2.52	39.82	2.60	41.52	2.64	
				70	29.16	2.43	35.55	2.48	36.64	2.53	37.27	2.55	39.46	2.63	41.18	2.67	
				73	29.16	2.49	34.68	2.54	35.83	2.59	36.48	2.62	38.76	2.69	40.54	2.73	
				77	29.16	2.55	33.86	2.60	35.07	2.65	35.75	2.68	38.11	2.75	39.95	2.79	
				81	29.16	2.62	33.09	2.67	34.35	2.72	35.06	2.74	37.51	2.81	39.40	2.86	
				84	29.16	2.68	32.36	2.74	33.68	2.78	34.42	2.81	36.95	2.88	38.90	2.92	
				88	29.16	2.75	31.67	2.80	33.05	2.85	33.82	2.88	36.43	2.95	38.44	2.99	
				91	29.16	2.82	31.04	2.87	32.47	2.92	33.26	2.95	35.97	3.02	38.03	3.06	
				95	29.16	2.89	30.44	2.94	31.93	2.99	33.00	3.01	35.55	3.09	37.67	3.13	
				99	29.16	2.97	29.90	3.02	31.44	3.07	32.30	3.09	35.17	3.16	37.35	3.20	
				102	29.16	3.04	29.40	3.09	31.00	3.14	31.88	3.16	34.84	3.23	37.08	3.28	
				108	29.16	3.16	28.73	3.21	30.42	3.25	31.35	3.28	34.43	3.35	36.76	3.39	
				111	29.16	3.23	28.35	3.28	30.09	3.33	31.05	3.36	34.22	3.42	36.60	3.47	
115	29.16	3.32	28.01	3.36	29.81	3.41	30.79	3.44	34.05	3.50	36.49	3.55					
9	12	18	39	68	30.05	2.46	37.09	2.51	38.19	2.57	38.82	2.59	41.03	2.66	42.78	2.71	
				70	30.05	2.49	36.63	2.54	37.75	2.60	38.40	2.62	40.65	2.69	42.43	2.74	
				73	30.05	2.55	35.73	2.61	36.92	2.66	37.59	2.68	39.94	2.76	41.77	2.80	
				77	30.05	2.62	34.89	2.67	36.13	2.72	36.83	2.75	39.27	2.82	41.16	2.87	
				81	30.05	2.69	34.09	2.74	35.39	2.79	36.12	2.82	38.64	2.89	40.59	2.93	
				84	30.05	2.75	33.34	2.81	34.70	2.86	35.46	2.88	38.07	2.96	40.08	3.00	
				88	30.05	2.83	32.63	2.88	34.05	2.93	34.84	2.95	37.54	3.02	39.61	3.07	
				91	30.05	2.90	31.98	2.95	33.45	3.00	34.27	3.02	37.06	3.10	39.19	3.14	
				95	30.05	2.97	31.37	3.02	32.90	3.07	34.00	3.09	36.62	3.17	38.81	3.21	
				99	30.05	3.05	30.80	3.10	32.40	3.15	33.28	3.17	36.24	3.24	38.48	3.29	
				102	30.05	3.12	30.29	3.17	31.94	3.22	32.85	3.25	35.90	3.32	38.20	3.36	
				108	30.05	3.24	29.60	3.29	31.34	3.34	32.30	3.37	35.48	3.44	37.87	3.48	
				111	30.05	3.32	29.21	3.37	31.01	3.42	31.99	3.45	35.26	3.52	37.71	3.56	
115	30.05	3.40	28.86	3.45	30.72	3.50	31.73	3.53	35.08	3.60	37.59	3.64					
9	18	18	45	68	30.05	2.46	37.09	2.51	38.19	2.57	38.82	2.59	39.50	2.62	41.03	2.66	
				70	30.05	2.49	36.63	2.54	37.75	2.60	38.40	2.62	39.09	2.65	40.65	2.69	
				73	30.05	2.55	35.73	2.61	36.92	2.66	37.59	2.68	38.32	2.71	39.94	2.76	
				77	30.05	2.62	34.89	2.67	36.13	2.72	36.83	2.75	37.59	2.77	39.27	2.82	
				81	30.05	2.69	34.09	2.74	35.39	2.79	36.12	2.82	36.91	2.84	38.64	2.89	
				84	30.05	2.75	33.34	2.81	34.70	2.86	35.46	2.88	36.27	2.91	38.07	2.96	
				88	30.05	2.83	32.63	2.88	34.05	2.93	34.84	2.95	35.69	2.98	37.54	3.02	
				91	30.05	2.90	31.98	2.95	33.45	3.00	34.27	3.02	35.15	3.05	37.06	3.10	
				95	30.05	2.97	31.37	3.02	32.90	3.07	34.00	3.09	34.65	3.12	36.62	3.17	
				99	30.05	3.05	30.80	3.10	32.40	3.15	33.28	3.17	34.21	3.20	36.24	3.24	
				102	30.05	3.12	30.29	3.17	31.94	3.22	32.85	3.25	33.81	3.27	35.90	3.32	
				108	30.05	3.24	29.60	3.29	31.34	3.34	32.30	3.37	33.30	3.39	35.48	3.44	
				111	30.05	3.32	29.21	3.37	31.01	3.42	31.99	3.45	33.02	3.47	35.26	3.52	
115	30.05	3.40	28.86	3.45	30.72	3.50	31.73	3.53	32.79	3.55	35.08	3.60					

# Capacity Table

JXH36S4T(AJ036TXS4CH/AA)

Cooling(Ducted)

Combination (Capacity Index)				Combination (Total)	Outdoor Temperature (°F, DB)	Indoor Temperature(°F, WB)											
						57.2		60.8		64.4		67		71.6		75.2	
						TC(kW)	PI(kW)	TC(kW)	PI(kW)	TC(kW)	PI(kW)	TC(kW)	PI(kW)	TC(kW)	PI(kW)	TC(kW)	PI(kW)
12	12	12		36	68	30.05	2.46	37.09	2.51	38.19	2.57	38.82	2.59	41.03	2.66	42.78	2.71
					70	30.05	2.49	36.63	2.54	37.75	2.60	38.40	2.62	40.65	2.69	42.43	2.74
					73	30.05	2.55	35.73	2.61	36.92	2.66	37.59	2.68	39.94	2.76	41.77	2.80
					77	30.05	2.62	34.89	2.67	36.13	2.72	36.83	2.75	39.27	2.82	41.16	2.87
					81	30.05	2.69	34.09	2.74	35.39	2.79	36.12	2.82	38.64	2.89	40.59	2.93
					84	30.05	2.75	33.34	2.81	34.70	2.86	35.46	2.88	38.07	2.96	40.08	3.00
					88	30.05	2.83	32.63	2.88	34.05	2.93	34.84	2.95	37.54	3.02	39.61	3.07
					91	30.05	2.90	31.98	2.95	33.45	3.00	34.27	3.02	37.06	3.10	39.19	3.14
					95	30.05	2.97	31.37	3.02	32.90	3.07	34.00	3.09	36.62	3.17	38.81	3.21
					99	30.05	3.05	30.80	3.10	32.40	3.15	33.28	3.17	36.24	3.24	38.48	3.29
					102	30.05	3.12	30.29	3.17	31.94	3.22	32.85	3.25	35.90	3.32	38.20	3.36
					108	30.05	3.24	29.60	3.29	31.34	3.34	32.30	3.37	35.48	3.44	37.87	3.48
					111	30.05	3.32	29.21	3.37	31.01	3.42	31.99	3.45	35.26	3.52	37.71	3.56
115	30.05	3.40	28.86	3.45	30.72	3.50	31.73	3.53	35.08	3.60	37.59	3.64					
12	12	18		42	68	30.05	2.46	37.09	2.51	38.19	2.57	38.82	2.59	39.50	2.62	41.03	2.66
					70	30.05	2.49	36.63	2.54	37.75	2.60	38.40	2.62	39.09	2.65	40.65	2.69
					73	30.05	2.55	35.73	2.61	36.92	2.66	37.59	2.68	38.32	2.71	39.94	2.76
					77	30.05	2.62	34.89	2.67	36.13	2.72	36.83	2.75	37.59	2.77	39.27	2.82
					81	30.05	2.69	34.09	2.74	35.39	2.79	36.12	2.82	36.91	2.84	38.64	2.89
					84	30.05	2.75	33.34	2.81	34.70	2.86	35.46	2.88	36.27	2.91	38.07	2.96
					88	30.05	2.83	32.63	2.88	34.05	2.93	34.84	2.95	35.69	2.98	37.54	3.02
					91	30.05	2.90	31.98	2.95	33.45	3.00	34.27	3.02	35.15	3.05	37.06	3.10
					95	30.05	2.97	31.37	3.02	32.90	3.07	34.00	3.09	34.65	3.12	36.62	3.17
					99	30.05	3.05	30.80	3.10	32.40	3.15	33.28	3.17	34.21	3.20	36.24	3.24
					102	30.05	3.12	30.29	3.17	31.94	3.22	32.85	3.25	33.81	3.27	35.90	3.32
					108	30.05	3.24	29.60	3.29	31.34	3.34	32.30	3.37	33.30	3.39	35.48	3.44
					111	30.05	3.32	29.21	3.37	31.01	3.42	31.99	3.45	33.02	3.47	35.26	3.52
115	30.05	3.40	28.86	3.45	30.72	3.50	31.73	3.53	32.79	3.55	35.08	3.60					
12	18	18		48	68	34.93	2.47	36.44	2.52	37.98	2.56	38.76	2.59	39.54	2.61	41.13	2.66
					70	34.60	2.50	36.12	2.55	37.66	2.60	38.44	2.62	39.22	2.64	40.80	2.69
					73	33.94	2.56	35.47	2.61	37.01	2.66	37.79	2.69	38.57	2.71	40.16	2.76
					77	33.29	2.63	34.81	2.68	36.36	2.73	37.14	2.75	37.93	2.78	39.52	2.82
					81	32.64	2.70	34.17	2.74	35.72	2.79	36.50	2.82	37.29	2.84	38.88	2.89
					84	31.99	2.76	33.52	2.81	35.07	2.86	35.86	2.89	36.65	2.91	38.24	2.96
					88	31.34	2.83	32.87	2.88	34.43	2.93	35.22	2.96	36.01	2.98	37.61	3.03
					91	30.70	2.90	32.23	2.95	33.79	3.00	34.58	3.03	35.37	3.05	36.97	3.10
					95	30.05	2.97	31.59	3.02	33.15	3.07	34.00	3.09	34.73	3.12	36.34	3.17
					99	29.41	3.04	30.95	3.09	32.51	3.14	33.30	3.17	34.10	3.19	35.71	3.24
					102	28.77	3.12	30.31	3.17	31.88	3.22	32.67	3.24	33.47	3.27	35.08	3.32
					108	27.81	3.23	29.36	3.28	30.93	3.33	31.72	3.35	32.52	3.38	34.14	3.43
					111	27.17	3.30	28.72	3.35	30.30	3.40	31.09	3.43	31.89	3.46	33.51	3.51
115	26.54	3.38	28.09	3.43	29.67	3.48	30.46	3.51	31.26	3.53	32.89	3.59					

# Capacity Table

JXH36S4T(AJ036TXS4CH/AA)

Cooling(Ducted)

Combination (Capacity Index)				Combination (Total)	Outdoor Temperature (°F, DB)	Indoor Temperature(°F, WB)											
						57.2		60.8		64.4		67		71.6		75.2	
						TC(kW)	PI(kW)	TC(kW)	PI(kW)	TC(kW)	PI(kW)	TC(kW)	PI(kW)	TC(kW)	PI(kW)	TC(kW)	PI(kW)
9	9	9	9	36	68	30.05	2.46	37.09	2.51	38.19	2.57	38.82	2.59	41.03	2.66	42.78	2.71
					70	30.05	2.49	36.63	2.54	37.75	2.60	38.40	2.62	40.65	2.69	42.43	2.74
					73	30.05	2.55	35.73	2.61	36.92	2.66	37.59	2.68	39.94	2.76	41.77	2.80
					77	30.05	2.62	34.89	2.67	36.13	2.72	36.83	2.75	39.27	2.82	41.16	2.87
					81	30.05	2.69	34.09	2.74	35.39	2.79	36.12	2.82	38.64	2.89	40.59	2.93
					84	30.05	2.75	33.34	2.81	34.70	2.86	35.46	2.88	38.07	2.96	40.08	3.00
					88	30.05	2.83	32.63	2.88	34.05	2.93	34.84	2.95	37.54	3.02	39.61	3.07
					91	30.05	2.90	31.98	2.95	33.45	3.00	34.27	3.02	37.06	3.10	39.19	3.14
					95	30.05	2.97	31.37	3.02	32.90	3.07	34.00	3.09	36.62	3.17	38.81	3.21
					99	30.05	3.05	30.80	3.10	32.40	3.15	33.28	3.17	36.24	3.24	38.48	3.29
					102	30.05	3.12	30.29	3.17	31.94	3.22	32.85	3.25	35.90	3.32	38.20	3.36
					108	30.05	3.24	29.60	3.29	31.34	3.34	32.30	3.37	35.48	3.44	37.87	3.48
					111	30.05	3.32	29.21	3.37	31.01	3.42	31.99	3.45	35.26	3.52	37.71	3.56
					115	30.05	3.40	28.86	3.45	30.72	3.50	31.73	3.53	35.08	3.60	37.59	3.64
9	9	9	12	39	68	30.05	2.46	37.09	2.51	38.19	2.57	38.82	2.59	41.03	2.66	42.78	2.71
					70	30.05	2.49	36.63	2.54	37.75	2.60	38.40	2.62	40.65	2.69	42.43	2.74
					73	30.05	2.55	35.73	2.61	36.92	2.66	37.59	2.68	39.94	2.76	41.77	2.80
					77	30.05	2.62	34.89	2.67	36.13	2.72	36.83	2.75	39.27	2.82	41.16	2.87
					81	30.05	2.69	34.09	2.74	35.39	2.79	36.12	2.82	38.64	2.89	40.59	2.93
					84	30.05	2.75	33.34	2.81	34.70	2.86	35.46	2.88	38.07	2.96	40.08	3.00
					88	30.05	2.83	32.63	2.88	34.05	2.93	34.84	2.95	37.54	3.02	39.61	3.07
					91	30.05	2.90	31.98	2.95	33.45	3.00	34.27	3.02	37.06	3.10	39.19	3.14
					95	30.05	2.97	31.37	3.02	32.90	3.07	34.00	3.09	36.62	3.17	38.81	3.21
					99	30.05	3.05	30.80	3.10	32.40	3.15	33.28	3.17	36.24	3.24	38.48	3.29
					102	30.05	3.12	30.29	3.17	31.94	3.22	32.85	3.25	35.90	3.32	38.20	3.36
					108	30.05	3.24	29.60	3.29	31.34	3.34	32.30	3.37	35.48	3.44	37.87	3.48
					111	30.05	3.32	29.21	3.37	31.01	3.42	31.99	3.45	35.26	3.52	37.71	3.56
					115	30.05	3.40	28.86	3.45	30.72	3.50	31.73	3.53	35.08	3.60	37.59	3.64
9	9	9	18	45	68	30.05	2.46	37.09	2.51	38.19	2.57	38.82	2.59	39.50	2.62	41.03	2.66
					70	30.05	2.49	36.63	2.54	37.75	2.60	38.40	2.62	39.09	2.65	40.65	2.69
					73	30.05	2.55	35.73	2.61	36.92	2.66	37.59	2.68	38.32	2.71	39.94	2.76
					77	30.05	2.62	34.89	2.67	36.13	2.72	36.83	2.75	37.59	2.77	39.27	2.82
					81	30.05	2.69	34.09	2.74	35.39	2.79	36.12	2.82	36.91	2.84	38.64	2.89
					84	30.05	2.75	33.34	2.81	34.70	2.86	35.46	2.88	36.27	2.91	38.07	2.96
					88	30.05	2.83	32.63	2.88	34.05	2.93	34.84	2.95	35.69	2.98	37.54	3.02
					91	30.05	2.90	31.98	2.95	33.45	3.00	34.27	3.02	35.15	3.05	37.06	3.10
					95	30.05	2.97	31.37	3.02	32.90	3.07	34.00	3.09	34.65	3.12	36.62	3.17
					99	30.05	3.05	30.80	3.10	32.40	3.15	33.28	3.17	34.21	3.20	36.24	3.24
					102	30.05	3.12	30.29	3.17	31.94	3.22	32.85	3.25	33.81	3.27	35.90	3.32
					108	30.05	3.24	29.60	3.29	31.34	3.34	32.30	3.37	33.30	3.39	35.48	3.44
					111	30.05	3.32	29.21	3.37	31.01	3.42	31.99	3.45	33.02	3.47	35.26	3.52
					115	30.05	3.40	28.86	3.45	30.72	3.50	31.73	3.53	32.79	3.55	35.08	3.60



# Capacity Table

JXH36S4T(AJ036TXS4CH/AA)

Cooling(Ducted)

Combination (Capacity Index)				Combination (Total)	Outdoor Temperature (°F, DB)	Indoor Temperature(°F, WB)											
						57.2		60.8		64.4		67		71.6		75.2	
						TC(kW)	PI(kW)	TC(kW)	PI(kW)	TC(kW)	PI(kW)	TC(kW)	PI(kW)	TC(kW)	PI(kW)	TC(kW)	PI(kW)
9	9	12	12	42	68	30.05	2.46	37.09	2.51	38.19	2.57	38.82	2.59	39.50	2.62	41.03	2.66
					70	30.05	2.49	36.63	2.54	37.75	2.60	38.40	2.62	39.09	2.65	40.65	2.69
					73	30.05	2.55	35.73	2.61	36.92	2.66	37.59	2.68	38.32	2.71	39.94	2.76
					77	30.05	2.62	34.89	2.67	36.13	2.72	36.83	2.75	37.59	2.77	39.27	2.82
					81	30.05	2.69	34.09	2.74	35.39	2.79	36.12	2.82	36.91	2.84	38.64	2.89
					84	30.05	2.75	33.34	2.81	34.70	2.86	35.46	2.88	36.27	2.91	38.07	2.96
					88	30.05	2.83	32.63	2.88	34.05	2.93	34.84	2.95	35.69	2.98	37.54	3.02
					91	30.05	2.90	31.98	2.95	33.45	3.00	34.27	3.02	35.15	3.05	37.06	3.10
					95	30.05	2.97	31.37	3.02	32.90	3.07	34.00	3.09	34.65	3.12	36.62	3.17
					99	30.05	3.05	30.80	3.10	32.40	3.15	33.28	3.17	34.21	3.20	36.24	3.24
					102	30.05	3.12	30.29	3.17	31.94	3.22	32.85	3.25	33.81	3.27	35.90	3.32
					108	30.05	3.24	29.60	3.29	31.34	3.34	32.30	3.37	33.30	3.39	35.48	3.44
					111	30.05	3.32	29.21	3.37	31.01	3.42	31.99	3.45	33.02	3.47	35.26	3.52
115	30.05	3.40	28.86	3.45	30.72	3.50	31.73	3.53	32.79	3.55	35.08	3.60					
9	9	12	18	48	68	34.93	2.47	36.44	2.52	37.98	2.56	38.76	2.59	39.54	2.61	41.13	2.66
					70	34.60	2.50	36.12	2.55	37.66	2.60	38.44	2.62	39.22	2.64	40.80	2.69
					73	33.94	2.56	35.47	2.61	37.01	2.66	37.79	2.69	38.57	2.71	40.16	2.76
					77	33.29	2.63	34.81	2.68	36.36	2.73	37.14	2.75	37.93	2.78	39.52	2.82
					81	32.64	2.70	34.17	2.74	35.72	2.79	36.50	2.82	37.29	2.84	38.88	2.89
					84	31.99	2.76	33.52	2.81	35.07	2.86	35.86	2.89	36.65	2.91	38.24	2.96
					88	31.34	2.83	32.87	2.88	34.43	2.93	35.22	2.96	36.01	2.98	37.61	3.03
					91	30.70	2.90	32.23	2.95	33.79	3.00	34.58	3.03	35.37	3.05	36.97	3.10
					95	30.05	2.97	31.59	3.02	33.15	3.07	34.00	3.09	34.73	3.12	36.34	3.17
					99	29.41	3.04	30.95	3.09	32.51	3.14	33.30	3.17	34.10	3.19	35.71	3.24
					102	28.77	3.12	30.31	3.17	31.88	3.22	32.67	3.24	33.47	3.27	35.08	3.32
					108	27.81	3.23	29.36	3.28	30.93	3.33	31.72	3.35	32.52	3.38	34.14	3.43
					111	27.17	3.30	28.72	3.35	30.30	3.40	31.09	3.43	31.89	3.46	33.51	3.51
115	26.54	3.38	28.09	3.43	29.67	3.48	30.46	3.51	31.26	3.53	32.89	3.59					
9	12	12	12	45	68	30.05	2.46	37.09	2.51	38.19	2.57	38.82	2.59	39.50	2.62	41.03	2.66
					70	30.05	2.49	36.63	2.54	37.75	2.60	38.40	2.62	39.09	2.65	40.65	2.69
					73	30.05	2.55	35.73	2.61	36.92	2.66	37.59	2.68	38.32	2.71	39.94	2.76
					77	30.05	2.62	34.89	2.67	36.13	2.72	36.83	2.75	37.59	2.77	39.27	2.82
					81	30.05	2.69	34.09	2.74	35.39	2.79	36.12	2.82	36.91	2.84	38.64	2.89
					84	30.05	2.75	33.34	2.81	34.70	2.86	35.46	2.88	36.27	2.91	38.07	2.96
					88	30.05	2.83	32.63	2.88	34.05	2.93	34.84	2.95	35.69	2.98	37.54	3.02
					91	30.05	2.90	31.98	2.95	33.45	3.00	34.27	3.02	35.15	3.05	37.06	3.10
					95	30.05	2.97	31.37	3.02	32.90	3.07	34.00	3.09	34.65	3.12	36.62	3.17
					99	30.05	3.05	30.80	3.10	32.40	3.15	33.28	3.17	34.21	3.20	36.24	3.24
					102	30.05	3.12	30.29	3.17	31.94	3.22	32.85	3.25	33.81	3.27	35.90	3.32
					108	30.05	3.24	29.60	3.29	31.34	3.34	32.30	3.37	33.30	3.39	35.48	3.44
					111	30.05	3.32	29.21	3.37	31.01	3.42	31.99	3.45	33.02	3.47	35.26	3.52
115	30.05	3.40	28.86	3.45	30.72	3.50	31.73	3.53	32.79	3.55	35.08	3.60					

# Capacity Table

JXH36S4T (AJ036TXS4CH/AA)

Cooling(Ducted)

Combination (Capacity Index)				Combination (Total)	Outdoor Temperature (°F,DB)	Indoor Temperature(°F, WB)											
						57.2		60.8		64.4		67		71.6		75.2	
						TC(kW)	PI(kW)	TC(kW)	PI(kW)	TC(kW)	PI(kW)	TC(kW)	PI(kW)	TC(kW)	PI(kW)	TC(kW)	PI(kW)
12	12	12	12	48	68	34.93	2.47	36.44	2.52	37.98	2.56	38.76	2.59	39.54	2.61	41.13	2.66
					70	34.60	2.50	36.12	2.55	37.66	2.60	38.44	2.62	39.22	2.64	40.80	2.69
					73	33.94	2.56	35.47	2.61	37.01	2.66	37.79	2.69	38.57	2.71	40.16	2.76
					77	33.29	2.63	34.81	2.68	36.36	2.73	37.14	2.75	37.93	2.78	39.52	2.82
					81	32.64	2.70	34.17	2.74	35.72	2.79	36.50	2.82	37.29	2.84	38.88	2.89
					84	31.99	2.76	33.52	2.81	35.07	2.86	35.86	2.89	36.65	2.91	38.24	2.96
					88	31.34	2.83	32.87	2.88	34.43	2.93	35.22	2.96	36.01	2.98	37.61	3.03
					91	30.70	2.90	32.23	2.95	33.79	3.00	34.58	3.03	35.37	3.05	36.97	3.10
					95	30.05	2.97	31.59	3.02	33.15	3.07	34.00	3.09	34.73	3.12	36.34	3.17
					99	29.41	3.04	30.95	3.09	32.51	3.14	33.30	3.17	34.10	3.19	35.71	3.24
					102	28.77	3.12	30.31	3.17	31.88	3.22	32.67	3.24	33.47	3.27	35.08	3.32
					108	27.81	3.23	29.36	3.28	30.93	3.33	31.72	3.35	32.52	3.38	34.14	3.43
					111	27.17	3.30	28.72	3.35	30.30	3.40	31.09	3.43	31.89	3.46	33.51	3.51
					115	26.54	3.38	28.09	3.43	29.67	3.48	30.46	3.51	31.26	3.53	32.89	3.59

1. Cooling capacity is based on 80°F(26.7°C) DB, 67°F(19.4°C) WB (indoor temperature), 95°F(35°C) DB (outdoor temperature).

2. Heating capacity is based on 70°F(21.1°C) DB (indoor temperature), 47°F(8.3°C) DB, 43°F(6.1°C) (outdoor temperature).

3. The above is the value for connecting with the following indoor units.

- Ducted Type

4. Capacities are based on the following conditions:

- Corresponding refrigerant piping length 16.4ft(5m), Level differences 0ft(0m)

5. The total combination Index of connected a indoor unit is up to 48.

6. It is impossible to connect the indoor unit for one room only.

7. This data is reference data for temperature capacity trend.

# Capacity Table

JXH36S4T(AJ036TXS4CH/AA)

Heating(Ducted)

Combination (Capacity Index)				Combination (Total)	Outdoor Temperature (°F,DB)	Indoor Temperature(°F, DB)											
						57		60.8		64.4		69.98		71.6		75.2	
						TC(kbtu)	PI(kW)	TC(kbtu)	PI(kW)	TC(kbtu)	PI(kW)	TC(kbtu)	PI(kW)	TC(kbtu)	PI(kW)	TC(kbtu)	PI(kW)
9				9	-13	14.25	3.47	12.24	2.96	10.64	2.62	7.62	1.95	6.77	1.66	4.82	1.17
					5	11.91	2.21	11.62	2.23	11.34	2.25	10.90	2.38	10.77	2.30	10.49	2.32
					17	11.36	1.88	11.21	1.91	11.01	1.92	10.90	2.05	10.82	1.97	10.61	1.99
					32	11.51	1.41	11.34	1.42	11.17	1.44	10.90	1.52	10.82	1.46	10.65	1.48
					47	11.83	1.03	11.42	1.00	11.27	1.01	10.90	1.07	10.81	1.00	10.19	0.95
					50	12.86	1.19	12.21	1.12	11.84	1.10	10.90	1.05	10.63	0.98	10.02	0.93
					59	13.06	1.18	12.45	1.12	11.84	1.07	10.90	1.03	10.63	0.96	10.02	0.90
12				12	-13	18.30	4.18	15.72	3.57	13.67	3.16	9.79	2.35	8.70	2.00	6.19	1.41
					5	15.29	2.66	14.93	2.69	14.56	2.71	14.00	2.87	13.83	2.78	13.47	2.80
					17	14.59	2.27	14.40	2.30	14.15	2.32	14.00	2.47	13.89	2.37	13.63	2.40
					32	14.79	1.69	14.57	1.71	14.34	1.73	14.00	1.83	13.90	1.76	13.68	1.78
					47	15.20	1.24	14.67	1.20	14.47	1.21	14.00	1.29	13.88	1.20	13.09	1.14
					50	16.52	1.43	15.68	1.35	15.21	1.33	14.00	1.26	13.65	1.19	12.87	1.12
					59	16.77	1.42	15.99	1.36	15.21	1.29	14.00	1.24	13.65	1.16	12.87	1.09
18				18	-13	26.14	6.03	22.46	5.14	19.52	4.55	13.99	3.38	12.42	2.89	8.85	2.03
					5	21.85	3.83	21.33	3.88	20.81	3.91	20.00	4.14	19.76	4.00	19.24	4.04
					17	20.84	3.28	20.58	3.32	20.21	3.34	20.00	3.56	19.84	3.42	19.47	3.47
					32	21.13	2.44	20.81	2.46	20.49	2.50	20.00	2.64	19.86	2.54	19.54	2.57
					47	21.71	1.79	20.95	1.74	20.67	1.75	20.00	1.86	19.83	1.74	18.70	1.64
					50	23.60	2.06	22.40	1.94	21.73	1.92	20.00	1.82	19.50	1.71	18.39	1.61
					59	23.96	2.05	22.84	1.96	21.73	1.86	20.00	1.79	19.50	1.67	18.39	1.57
9	9			18	-13	24.54	6.86	20.52	5.44	19.69	5.52	15.24	4.02	13.51	3.35	9.63	2.17
					5	23.84	4.62	23.27	4.67	22.69	4.74	21.80	4.92	21.55	4.84	20.98	4.88
					17	23.23	4.00	22.83	4.04	22.43	4.08	21.80	4.23	21.63	4.17	21.22	4.21
					32	23.04	2.97	22.69	3.00	22.34	3.03	21.80	3.14	21.65	3.08	21.30	3.11
					47	23.10	2.09	22.83	2.11	22.53	2.13	21.80	2.21	21.92	2.17	21.62	2.19
					50	22.78	2.04	22.50	2.05	22.23	2.07	21.80	2.14	21.68	2.11	21.40	2.12
					59	23.80	2.04	22.79	2.07	22.54	2.09	21.80	2.08	21.26	2.15	20.05	2.17
9	12			21	-13	28.02	7.33	23.44	5.81	22.49	5.90	17.41	4.29	15.44	3.58	11.00	2.32
					5	27.23	4.94	26.58	4.99	25.92	5.06	24.90	5.25	24.62	5.16	23.96	5.22
					17	26.53	4.27	26.07	4.32	25.61	4.36	24.90	4.52	24.70	4.45	24.24	4.50
					32	26.32	3.18	25.92	3.21	25.52	3.24	24.90	3.35	24.73	3.29	24.33	3.32
					47	26.39	2.23	26.08	2.25	25.74	2.27	24.90	2.36	25.04	2.31	24.69	2.34
					50	26.02	2.18	25.70	2.19	25.39	2.21	24.90	2.29	24.76	2.25	24.45	2.27
					59	27.19	2.18	26.03	2.22	25.74	2.23	24.90	2.22	24.29	2.30	22.90	2.32
9	18			27	-13	34.78	8.17	29.09	6.47	27.90	6.57	21.61	4.78	19.16	3.99	13.66	2.58
					5	33.79	5.50	32.98	5.56	32.17	5.64	30.90	5.85	30.55	5.75	29.74	5.81
					17	32.92	4.76	32.36	4.81	31.79	4.86	30.90	5.03	30.66	4.96	30.08	5.01
					32	32.66	3.54	32.17	3.57	31.67	3.61	30.90	3.73	30.69	3.67	30.19	3.70
					47	32.75	2.49	32.36	2.51	31.94	2.53	30.90	2.63	31.07	2.58	30.64	2.61
					50	32.29	2.42	31.90	2.45	31.51	2.47	30.90	2.55	30.72	2.51	30.34	2.53
					59	33.74	2.43	32.30	2.47	31.94	2.49	30.90	2.47	30.14	2.56	28.41	2.58
12	12			24	-13	31.51	7.76	26.36	6.15	25.29	6.25	19.58	4.55	17.36	3.79	12.37	2.46
					5	30.62	5.23	29.89	5.28	29.15	5.36	28.00	5.56	27.68	5.47	26.94	5.53
					17	29.83	4.52	29.32	4.57	28.80	4.62	28.00	4.78	27.78	4.72	27.26	4.76
					32	29.59	3.37	29.15	3.40	28.70	3.43	28.00	3.55	27.81	3.49	27.36	3.52
					47	29.68	2.37	29.33	2.39	28.94	2.41	28.00	2.50	28.15	2.45	27.77	2.48
					50	29.26	2.30	28.90	2.32	28.55	2.34	28.00	2.43	27.84	2.38	27.49	2.40
					59	30.57	2.31	29.27	2.35	28.95	2.37	28.00	2.35	27.31	2.43	25.75	2.46

# Capacity Table

JXH36S4T(AJ036TXS4CH/AA)

Heating(Ducted)

Combination (Capacity Index)				Combination (Total)	Outdoor Temperature (°F,DB)	Indoor Temperature(°F, DB)											
						57		60.8		64.4		69.98		71.6		75.2	
						TC(kbtu)	PI(kW)	TC(kbtu)	PI(kW)	TC(kbtu)	PI(kW)	TC(kbtu)	PI(kW)	TC(kbtu)	PI(kW)	TC(kbtu)	PI(kW)
12	18			30	-13	38.27	9.16	32.01	7.26	30.70	7.37	23.78	5.36	21.08	4.47	15.03	2.90
					5	37.18	6.17	36.29	6.23	35.39	6.32	34.00	6.56	33.62	6.45	32.72	6.52
					17	36.23	5.34	35.60	5.40	34.98	5.45	34.00	5.65	33.73	5.57	33.10	5.62
					32	35.94	3.97	35.40	4.01	34.85	4.04	34.00	4.19	33.77	4.12	33.22	4.15
					47	36.03	2.79	35.61	2.82	35.14	2.84	34.00	2.95	34.19	2.89	33.72	2.92
					50	35.53	2.72	35.10	2.74	34.67	2.77	34.00	2.86	33.81	2.81	33.38	2.84
18	18			36	-13	38.94	9.16	32.57	7.26	31.25	7.37	24.20	5.36	21.45	4.47	15.29	2.90
					5	37.84	6.17	36.93	6.23	36.02	6.32	34.60	6.56	34.21	6.45	33.30	6.52
					17	36.87	5.34	36.23	5.40	35.59	5.45	34.60	5.65	34.33	5.57	33.69	5.62
					32	36.57	3.97	36.02	4.01	35.46	4.04	34.60	4.19	34.36	4.12	33.81	4.15
					47	36.67	2.79	36.24	2.82	35.76	2.84	34.60	2.95	34.79	2.89	34.31	2.92
					50	36.16	2.72	35.72	2.74	35.29	2.77	34.60	2.86	34.40	2.81	33.97	2.84
9	9	9		27	-13	26.23	4.90	25.01	4.94	24.30	5.01	22.87	5.07	22.15	5.14	20.72	5.14
					5	35.32	6.00	34.56	6.06	33.57	6.14	32.70	6.21	31.96	6.27	31.34	6.32
					17	34.83	5.15	34.19	5.21	33.40	5.28	32.70	5.34	32.09	5.39	31.56	5.44
					32	34.68	3.82	34.08	3.86	33.35	3.92	32.70	3.96	32.13	4.00	31.63	4.04
					47	34.54	2.69	33.98	2.72	33.31	2.76	32.70	2.79	32.16	2.82	31.69	2.85
					50	34.47	2.58	33.92	2.61	33.28	2.65	32.70	2.68	32.18	2.71	31.72	2.73
9	9	12		30	-13	27.75	5.18	26.46	5.23	25.71	5.29	24.20	5.36	23.44	5.43	21.93	5.43
					5	37.37	6.34	36.57	6.41	35.52	6.49	34.60	6.56	33.82	6.63	33.17	6.68
					17	36.85	5.45	36.18	5.51	35.34	5.58	34.60	5.65	33.95	5.70	33.40	5.75
					32	36.69	4.04	36.06	4.09	35.29	4.14	34.60	4.19	33.99	4.23	33.47	4.27
					47	36.55	2.84	35.95	2.88	35.24	2.92	34.60	2.95	34.03	2.98	33.53	3.01
					50	36.47	2.73	35.89	2.76	35.21	2.80	34.60	2.83	34.05	2.86	33.57	2.89
9	9	18		36	-13	27.75	5.18	26.46	5.23	25.71	5.29	24.20	5.36	23.44	5.43	21.93	5.43
					5	37.37	6.34	36.57	6.41	35.52	6.49	34.60	6.56	33.82	6.63	33.17	6.68
					17	36.85	5.45	36.18	5.51	35.34	5.58	34.60	5.65	33.95	5.70	33.40	5.75
					32	36.69	4.04	36.06	4.09	35.29	4.14	34.60	4.19	33.99	4.23	33.47	4.27
					47	36.55	2.84	35.95	2.88	35.24	2.92	34.60	2.95	34.03	2.98	33.53	3.01
					50	36.47	2.73	35.89	2.76	35.21	2.80	34.60	2.83	34.05	2.86	33.57	2.89
9	12	12		33	-13	27.75	5.18	26.46	5.23	25.71	5.29	24.20	5.36	23.44	5.43	21.93	5.43
					5	37.37	6.34	36.57	6.41	35.52	6.49	34.60	6.56	33.82	6.63	33.17	6.68
					17	36.85	5.45	36.18	5.51	35.34	5.58	34.60	5.65	33.95	5.70	33.40	5.75
					32	36.69	4.04	36.06	4.09	35.29	4.14	34.60	4.19	33.99	4.23	33.47	4.27
					47	36.55	2.84	35.95	2.88	35.24	2.92	34.60	2.95	34.03	2.98	33.53	3.01
					50	36.47	2.73	35.89	2.76	35.21	2.80	34.60	2.83	34.05	2.86	33.57	2.89
9	12	18		39	-13	27.75	5.18	26.46	5.23	25.71	5.29	24.20	5.36	23.44	5.43	21.93	5.43
					5	37.37	6.34	36.57	6.41	35.52	6.49	34.60	6.56	33.82	6.63	33.17	6.68
					17	36.85	5.45	36.18	5.51	35.34	5.58	34.60	5.65	33.95	5.70	33.40	5.75
					32	36.69	4.04	36.06	4.09	35.29	4.14	34.60	4.19	33.99	4.23	33.47	4.27
					47	36.55	2.84	35.95	2.88	35.24	2.92	34.60	2.95	34.03	2.98	33.53	3.01
					50	36.47	2.73	35.89	2.76	35.21	2.80	34.60	2.83	34.05	2.86	33.57	2.89
					59	36.39	2.61	35.83	2.65	35.19	2.68	34.60	2.71	34.07	2.74	33.60	2.77

# Capacity Table

JXH36S4T(AJ036TXS4CH/AA)

Heating(Ducted)

Combination (Capacity Index)				Combination (Total)	Outdoor Temperature (°F,DB)	Indoor Temperature(°F, DB)											
						57		60.8		64.4		69.98		71.6		75.2	
						TC(kbtu)	PI(kW)	TC(kbtu)	PI(kW)	TC(kbtu)	PI(kW)	TC(kbtu)	PI(kW)	TC(kbtu)	PI(kW)	TC(kbtu)	PI(kW)
9	18	18		45	-13	27.75	5.18	26.46	5.23	25.71	5.29	24.20	5.36	23.44	5.43	21.93	5.43
					5	37.37	6.34	36.57	6.41	35.52	6.49	34.60	6.56	33.82	6.63	33.17	6.68
					17	36.85	5.45	36.18	5.51	35.34	5.58	34.60	5.65	33.95	5.70	33.40	5.75
					32	36.69	4.04	36.06	4.09	35.29	4.14	34.60	4.19	33.99	4.23	33.47	4.27
					47	36.55	2.84	35.95	2.88	35.24	2.92	34.60	2.95	34.03	2.98	33.53	3.01
					50	36.47	2.73	35.89	2.76	35.21	2.80	34.60	2.83	34.05	2.86	33.57	2.89
12	12	12		36	-13	27.75	5.18	26.46	5.23	25.71	5.29	24.20	5.36	23.44	5.43	21.93	5.43
					5	37.37	6.34	36.57	6.41	35.52	6.49	34.60	6.56	33.82	6.63	33.17	6.68
					17	36.85	5.45	36.18	5.51	35.34	5.58	34.60	5.65	33.95	5.70	33.40	5.75
					32	36.69	4.04	36.06	4.09	35.29	4.14	34.60	4.19	33.99	4.23	33.47	4.27
					47	36.55	2.84	35.95	2.88	35.24	2.92	34.60	2.95	34.03	2.98	33.53	3.01
					50	36.47	2.73	35.89	2.76	35.21	2.80	34.60	2.83	34.05	2.86	33.57	2.89
12	12	18		42	-13	27.75	5.18	26.46	5.23	25.71	5.29	24.20	5.36	23.44	5.43	21.93	5.43
					5	37.37	6.34	36.57	6.41	35.52	6.49	34.60	6.56	33.82	6.63	33.17	6.68
					17	36.85	5.45	36.18	5.51	35.34	5.58	34.60	5.65	33.95	5.70	33.40	5.75
					32	36.69	4.04	36.06	4.09	35.29	4.14	34.60	4.19	33.99	4.23	33.47	4.27
					47	36.55	2.84	35.95	2.88	35.24	2.92	34.60	2.95	34.03	2.98	33.53	3.01
					50	36.47	2.73	35.89	2.76	35.21	2.80	34.60	2.83	34.05	2.86	33.57	2.89
12	18	18		48	-13	27.75	5.18	26.46	5.23	25.71	5.29	24.20	5.36	23.44	5.43	21.93	5.43
					5	37.37	6.34	36.57	6.41	35.52	6.49	34.60	6.56	33.82	6.63	33.17	6.68
					17	36.85	5.45	36.18	5.51	35.34	5.58	34.60	5.65	33.95	5.70	33.40	5.75
					32	36.69	4.04	36.06	4.09	35.29	4.14	34.60	4.19	33.99	4.23	33.47	4.27
					47	36.55	2.84	35.95	2.88	35.24	2.92	34.60	2.95	34.03	2.98	33.53	3.01
					50	36.47	2.73	35.89	2.76	35.21	2.80	34.60	2.83	34.05	2.86	33.57	2.89
9	9	9	9	36	-13	27.75	5.18	26.46	5.23	25.71	5.29	24.20	5.36	23.44	5.43	21.93	5.43
					5	37.37	6.34	36.57	6.41	35.52	6.49	34.60	6.56	33.82	6.63	33.17	6.68
					17	36.85	5.45	36.18	5.51	35.34	5.58	34.60	5.65	33.95	5.70	33.40	5.75
					32	36.69	4.04	36.06	4.09	35.29	4.14	34.60	4.19	33.99	4.23	33.47	4.27
					47	36.55	2.84	35.95	2.88	35.24	2.92	34.60	2.95	34.03	2.98	33.53	3.01
					50	36.47	2.73	35.89	2.76	35.21	2.80	34.60	2.83	34.05	2.86	33.57	2.89
9	9	9	12	39	-13	27.75	5.18	26.46	5.23	25.71	5.29	24.20	5.36	23.44	5.43	21.93	5.43
					5	37.37	6.34	36.57	6.41	35.52	6.49	34.60	6.56	33.82	6.63	33.17	6.68
					17	36.85	5.45	36.18	5.51	35.34	5.58	34.60	5.65	33.95	5.70	33.40	5.75
					32	36.69	4.04	36.06	4.09	35.29	4.14	34.60	4.19	33.99	4.23	33.47	4.27
					47	36.55	2.84	35.95	2.88	35.24	2.92	34.60	2.95	34.03	2.98	33.53	3.01
					50	36.47	2.73	35.89	2.76	35.21	2.80	34.60	2.83	34.05	2.86	33.57	2.89
9	9	9	18	45	-13	27.75	5.18	26.46	5.23	25.71	5.29	24.20	5.36	23.44	5.43	21.93	5.43
					5	37.37	6.34	36.57	6.41	35.52	6.49	34.60	6.56	33.82	6.63	33.17	6.68
					17	36.85	5.45	36.18	5.51	35.34	5.58	34.60	5.65	33.95	5.70	33.40	5.75
					32	36.69	4.04	36.06	4.09	35.29	4.14	34.60	4.19	33.99	4.23	33.47	4.27
					47	36.55	2.84	35.95	2.88	35.24	2.92	34.60	2.95	34.03	2.98	33.53	3.01
					50	36.47	2.73	35.89	2.76	35.21	2.80	34.60	2.83	34.05	2.86	33.57	2.89
					59	36.39	2.61	35.83	2.65	35.19	2.68	34.60	2.71	34.07	2.74	33.60	2.77



# Capacity Table

## JXH36S4T(AJ036TXS4CH/AA)

### Heating(Ducted)

Combination (Capacity Index)				Combination (Total)	Outdoor Temperature (°F,DB)	Indoor Temperature(°F, DB)											
						57		60.8		64.4		69.98		71.6		75.2	
						TC(kbtu)	PI(kW)	TC(kbtu)	PI(kW)	TC(kbtu)	PI(kW)	TC(kbtu)	PI(kW)	TC(kbtu)	PI(kW)	TC(kbtu)	PI(kW)
9	9	12	12	42	-13	27.75	5.18	26.46	5.23	25.71	5.29	24.20	5.36	23.44	5.43	21.93	5.43
					5	37.37	6.34	36.57	6.41	35.52	6.49	34.60	6.56	33.82	6.63	33.17	6.68
					17	36.85	5.45	36.18	5.51	35.34	5.58	34.60	5.65	33.95	5.70	33.40	5.75
					32	36.69	4.04	36.06	4.09	35.29	4.14	34.60	4.19	33.99	4.23	33.47	4.27
					47	36.55	2.84	35.95	2.88	35.24	2.92	34.60	2.95	34.03	2.98	33.53	3.01
					50	36.47	2.73	35.89	2.76	35.21	2.80	34.60	2.83	34.05	2.86	33.57	2.89
9	9	12	18	48	-13	27.75	5.18	26.46	5.23	25.71	5.29	24.20	5.36	23.44	5.43	21.93	5.43
					5	37.37	6.34	36.57	6.41	35.52	6.49	34.60	6.56	33.82	6.63	33.17	6.68
					17	36.85	5.45	36.18	5.51	35.34	5.58	34.60	5.65	33.95	5.70	33.40	5.75
					32	36.69	4.04	36.06	4.09	35.29	4.14	34.60	4.19	33.99	4.23	33.47	4.27
					47	36.55	2.84	35.95	2.88	35.24	2.92	34.60	2.95	34.03	2.98	33.53	3.01
					50	36.47	2.73	35.89	2.76	35.21	2.80	34.60	2.83	34.05	2.86	33.57	2.89
9	12	12	12	45	-13	27.75	5.18	26.46	5.23	25.71	5.29	24.20	5.36	23.44	5.43	21.93	5.43
					5	37.37	6.34	36.57	6.41	35.52	6.49	34.60	6.56	33.82	6.63	33.17	6.68
					17	36.85	5.45	36.18	5.51	35.34	5.58	34.60	5.65	33.95	5.70	33.40	5.75
					32	36.69	4.04	36.06	4.09	35.29	4.14	34.60	4.19	33.99	4.23	33.47	4.27
					47	36.55	2.84	35.95	2.88	35.24	2.92	34.60	2.95	34.03	2.98	33.53	3.01
					50	36.47	2.73	35.89	2.76	35.21	2.80	34.60	2.83	34.05	2.86	33.57	2.89
12	12	12	12	48	-13	27.75	5.18	26.46	5.23	25.71	5.29	24.20	5.36	23.44	5.43	21.93	5.43
					5	37.37	6.34	36.57	6.41	35.52	6.49	34.60	6.56	33.82	6.63	33.17	6.68
					17	36.85	5.45	36.18	5.51	35.34	5.58	34.60	5.65	33.95	5.70	33.40	5.75
					32	36.69	4.04	36.06	4.09	35.29	4.14	34.60	4.19	33.99	4.23	33.47	4.27
					47	36.55	2.84	35.95	2.88	35.24	2.92	34.60	2.95	34.03	2.98	33.53	3.01
					50	36.47	2.73	35.89	2.76	35.21	2.80	34.60	2.83	34.05	2.86	33.57	2.89
12	12	12	12	48	59	36.39	2.61	35.83	2.65	35.19	2.68	34.60	2.71	34.07	2.74	33.60	2.77

- Cooling capacity is based on 80°F(26.7°C) DB, 67°F(19.4°C) WB (indoor temperature), 95°F(35°C) DB (outdoor temperature).
- Heating capacity is based on 70°F(21.1°C) DB (indoor temperature), 47°F(8.3°C) DB, 43°F(6.1°C) (outdoor temperature).
- The above is the value for connecting with the following indoor units.
  - Ducted Type
- Capacities are based on the following conditions:
  - Corresponding refrigerant piping length 16.4ft(5m), Level differences 0ft(0m)
- The total combination Index of connected a indoor unit is up to 48.
- It is impossible to connect the indoor unit for one room only.
- This data is reference data for temperature capacity trend.

2020. 04  
Ver.1.0

Samsung Electronics Co., LTD.

Head Office (Suwon Korea) 129, Samsung-Ro, Yeongtong-Gu, Suwon City, Gyeonggi-Do, Korea 16677  
Website : [www.samsung.com](http://www.samsung.com), <https://partnerhub.samsung.com> Email : [airconditioner@samsung.com](mailto:airconditioner@samsung.com)  
Images and data in this book may subject to change without prior notice.